

MODELS:

RINNAI SS850 (SS850FCAN) NG

RINNAI SS850 (SS850FCAL) LPG

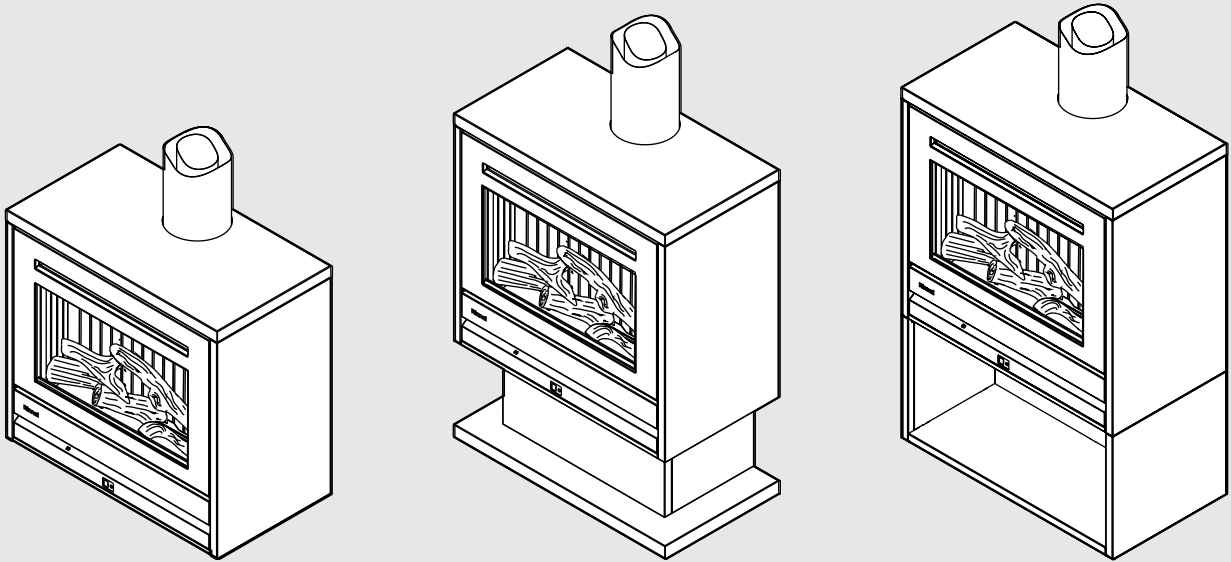

Gas Fireplace

Installation Manual

Rinnai

Congratulations on the purchase of your room-sealed Rinnai SS850 Freestanding Gas Fire. We trust you will have many years of comfort and enjoyment from your appliance.



BEFORE USING THIS APPLIANCE

Before proceeding with the installation read this manual thoroughly and gain a full understanding of the appliance, to ensure safe and correct use.

For details on how to operate this appliance safely and correctly refer the 'Operation Manual' supplied with the engine (Part Number: 13722).

This appliance must be installed in accordance with:

- Manufacturer's Installation Instructions
- Current AS/NZS 3000, AS/NZS 3500 & AS/NZS 5601
- Local Regulations and Municipal Building Codes including local OH&S requirements

This appliance must be installed, maintained and removed **ONLY** by an Authorised Person.

For continued safety of this appliance it must be installed and maintained in accordance with the manufacturer's instructions.



The Australian Gas Association
All Rinnai gas products sold in Australia are A.G.A. certified.

TABLE OF CONTENTS

Warnings & Important Information	4
Before Using or Installing this Appliance	4
Regulatory Information	4
Notice to Victorian Consumers	4
Dress Guard Warnings	4
Mandatory Inspection Prior to Installation	4
Modifications	5
General Safety Warnings	5
Before You Start	6
Installation Requirements	6
Certification	6
General Installation Information	7
Location	7
Flooring and Hearth Material Selection	8
Material Selection Calculations	9
Installation Examples	10
Supply Connections	11
Gas Supply	11
Gas Supply Locations	12
Electrical Supply	13
Installation	14
Freestander Installation	14
Aeration Plates	15
Cabinet Installation	16
Plinth Installation	19
Burner Media Installation	22
Burner Media Placement	22
Flueing	24
General Flueing Guidelines	24
Freestanding Flueing Options	25
General Flue Assembly Layout and Clearance Requirements	26
Flue Kits and Components	27
Commissioning	30
General Information	30
Commissioning the Appliance for Different Gas Type	33
Attaching Fascia Assembly	34
Abnormal Flame Pattern	35
Installation Checklist	36
Specifications	38
Appliance Details	38
Dimensions	39
Wiring Diagram	40
Contacts	44



This appliance **MUST** be installed, maintained and removed **ONLY** by an Authorised Person.
For continued safety of this appliance it **MUST** be installed and maintained in accordance with the manufacturers instructions.

WARNINGS & IMPORTANT INFORMATION



BEFORE USING OR INSTALLING THIS APPLIANCE

Before proceeding with the operation or installation read this manual thoroughly and gain a full understanding of the appliance, to ensure safe and correct use.

Failure to carefully read and follow all instructions in this manual can result in equipment malfunction, fire or explosion, property damage, personal injury and/or death.

DANGER: Indicates an imminently hazardous situation which, if not avoided, will result in personal injury or death.

WARNINGS: Indicates a potentially hazardous situation which, if not avoided, could result in personal injury or death.

CAUTIONS: Indicates a potentially hazardous situation which, if not avoided, could result in minor or moderate injury or damage to the appliance. It may also be used to alert against unsafe practices.



REGULATORY INFORMATION

This appliance shall be installed in accordance with:

Manufacturer's Installation Instructions.

Current AS/NZS 3000, AS/NZS 3500 & AS/NZS 5601.

Local Regulations and Municipal Building Codes including local OH&S requirements.

This appliance has been certified by the Australian Gas Association. The A.G.A. Certification Number is shown on the data plate.

This appliance **MUST** be installed, maintained and removed **ONLY** by an Authorised Person.

For continued safety of this appliance it **MUST** be installed and maintained in accordance with the manufacturer's instructions.

NOTICE TO VICTORIAN CONSUMERS

This appliance **MUST** be installed by a person licensed with the Victorian Building Authority. **ONLY** a licensed person will have insurance protecting their workmanship.

So make sure you use a licensed person to install this appliance and ask for your Compliance Certificate. For further information contact the Victorian Building Authority on 1300 815 127.



DRESS GUARD WARNINGS

The guard is fitted to this appliance to reduce the risk of fire or injury from burns and no part of it should be permanently removed. For protection of young children or the infirm, a secondary guard is required.

The glass guard supplied with this appliance **MUST NOT** be permanently removed as it fulfils an operational safety function. Additional dress guards including free standing types may be used in conjunction with, but **NOT** replace, the guard supplied with this appliance.



MANDATORY INSPECTION PRIOR TO INSTALLATION

Immediately report any damage or discrepancies to the supplier of the appliance. This appliance was inspected and tested at the time of manufacture and packaging, and released for transportation without known damage. Upon receipt, inspect the exterior for evidence of rough handling in shipment. Ensure that the appliance is labelled correctly for the gas and electrical supply, and/or other services it is intended to be connected to.

For safety and warranty purposes, appliances that may be damaged or incorrect **MUST NOT** be installed or operated under **ANY** circumstances. Installation of damaged or incorrect appliances may contravene local government regulations. Rinnai disclaims any liability or responsibility whatsoever in relation to the installation or operation of damaged or incorrect appliances.

Take care when opening or unpacking this appliance. Failure to do so may result in serious injury or product failure.

Check the label for the correct gas type (refer rating plate, inside the appliance). Refer to local gas authority for confirmation of the gas type if you are in doubt.



MODIFICATIONS

DO NOT MODIFY THIS APPLIANCE, modifying from original specifications may create a dangerous situation and will void your warranty. Failure to comply with these instructions could result in a fire or explosion, which could cause serious injury, death or property damage.

DO NOT modify the electrical wiring of this appliance.

If the power cord is damaged or deteriorated it **MUST** be replaced by an authorised person. Failure to do so may result in electric shock, fire, serious injury or product failure.

Improper installation, adjustments, service or maintenance can cause serious injury, death or property damage. Such work **MUST ONLY** be performed by an authorised person.



GENERAL SAFETY WARNINGS

This appliance is **HEAVY**, during installation the use of a mechanical lifting aid is recommended, noting that improper lifting may result in serious injury.

WARNING: This heater **MUST NOT** be used if any of the glass panels are damaged.

Flue terminal **MUST** always vent directly to outdoors. **DO NOT** extend the flue vertically or horizontally in ways other than prescribed in this appliance manufacturer's installation instructions. **ONLY** the flue components specified by Rinnai **MUST** be used.

When considering installation ensure the minimum clearances on page 7 are adhered to.

Heat radiating from the front of this heater may over time affect the appearance of some materials used for flooring such as carpet, vinyl, cork or timber. This effect may be amplified if the air in the room contains cooking vapours, candle vapours and cigarette smoke, etc. Refer to "Location" on page 7 for mantle clearances, additional installation information and warnings.

This appliance **MUST NOT** be installed where curtains or other combustible materials could come into contact with it. In some cases curtains may need restraining.

This appliance is **NOT** intended for use by persons (including children) with reduced physical, sensory or mental capabilities or lack of experience and knowledge, unless they have been given supervision or instruction concerning use of the appliance by a person responsible for their safety.

The appliance is **NOT** intended for use by young children or infirm persons without supervision. Young children and the infirm **SHOULD** be supervised at all times when in the vicinity of this heater while it is in operation.

The heater **MUST NOT** be located immediately below a power socket outlet.

A dedicated 230 V earthed 10 Amp power point must be used with this appliance.

Refer to local gas authority for confirmation of the gas type if you are in doubt.

Suitable **ONLY** for indoor installation.

DO NOT operate this appliance before leak checking hoses and gas cylinder connection.

This heater **MUST NOT** be used if either of the glass panels are damaged.

NOT to be connected to an LP gas cylinder located indoors.

Please keep this instruction booklet in a safe place for future reference. All dimensions referred to in these instructions are in millimetres, unless otherwise specified.

BEFORE YOU START

INSTALLATION REQUIREMENTS

This heater **MUST** be installed **ONLY** by an authorised person.

The installation **MUST** conform to local regulations.

The installation **MUST** also comply with the instructions supplied by Rinnai.

Service and removal **MUST** be carried out **ONLY** by an authorised person.

CERTIFICATION

The Rinnai SS850 Room-Sealed Freestanding Gas Fire has been certified by the Australian Gas Association.

The AGA Certification Number is shown on the appliance data plate.

No parts or functions should be modified or permanently removed from the heater.

Please keep these instructions in a safe place for future reference.

CARTON CONTENTS / ITEM CHECKLIST

The following table lists the components for the Rinnai SS850 Freestanding Gas Fires. Ensure that all the relevant components for the model being installed are present before proceeding.

IMPORTANT  **DO NOT** install any damaged items. Check all components have been supplied.

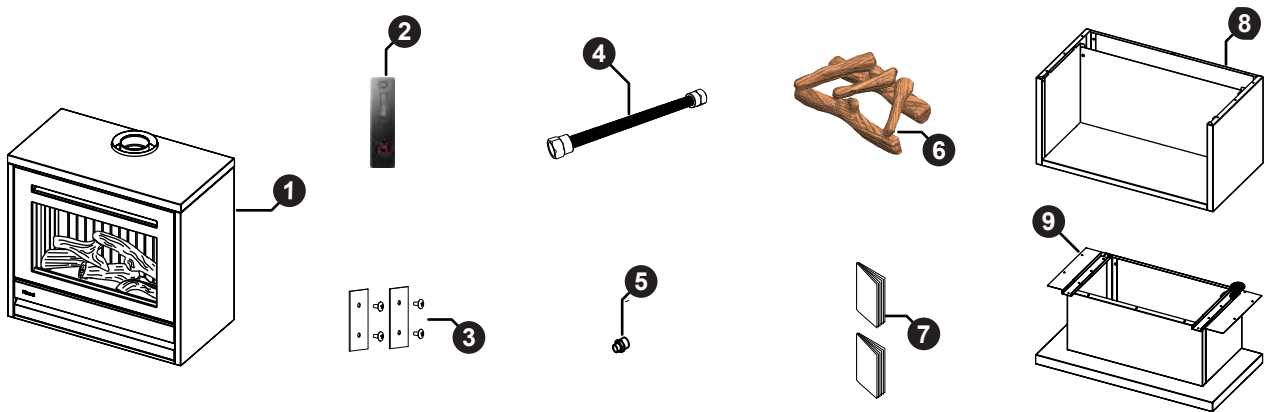

Major Component Descriptions and Carton Contents	
①	Rinnai SS850 Freestander including Engine, Wrap and Outer Frame
②	Remote Control, Infra Red (IR)
③	Aeration Plate and Screws.- Two are factory fitted on the engine, two are supplied in the accessory pack
④	Semi rigid stainless steel gas pipe with 5/8" connections (x1).
⑤	1/2" BSP - 5/8" UNF flared brass adaptors (x1).
⑥	Ceramic log set and granules.
⑦	Operation and Installation manual
Optional Accessories	
⑧	Freestanding Cabinet Base (SS850FSBC) - The cabinet comes as a flat pack. An additional flexi-pipe and connector is also provided as a longer gas connection is needed.
⑨	Freestanding Plinth Base (SS850FSBP) - The plinth comes as a flat pack. An additional flexi-pipe and connector is also provided as a longer gas connection is needed

GENERAL INSTALLATION INFORMATION

LOCATION

When positioning the heater, the main variables governing the location are Flueing and Warm Air Distribution. The Rinnai SS850 freestanding models have an additional metal wrap which significantly reduces unwanted heat transfer. This means the unit can be installed into tight spaces, can be built-in, and can be positioned close to walls if the building materials are suitable. For further information on material selection refer pages 8 and 9.

Combustible clearances

The heater **MUST NOT** be installed where curtains, furniture or other combustible materials could come into contact with the fire while it is operating. The side clearance, measured from the edge of the cabinet, includes side walls. The 1000 mm clearance is in front of the fire.

The general clearances shown in the adjacent diagrams (with cabinet base) apply to all the Rinnai SS850 Freestanding models.

Hearths

A hearth is not necessary but can be used for decorative purposes. It **MUST NOT** obscure the front of the fire or obstruct the fire in any way. For more information refer page 8.

Floor protection

Heat radiating from the fire may affect the appearance of some materials used for flooring such as vinyl planks, carpet, cork, or timber. To avoid this occurring it is recommended a mat be placed in front.



Carpet MUST NOT be fitted hard up against the fire as it will affect operation.

Surrounds

Combustible surrounds require clearance from the unit to minimise the risk of fire. They are allowed providing they are outside the minimum clearances shown.

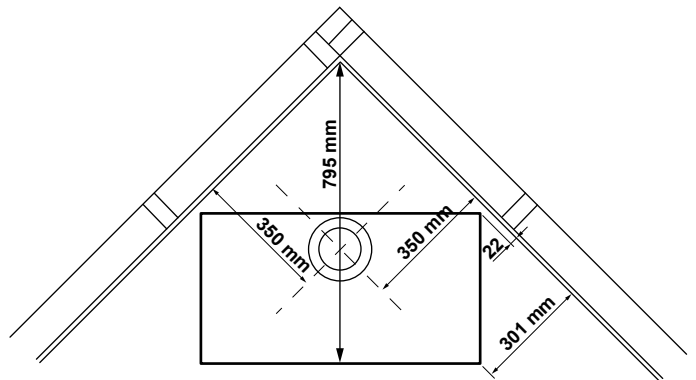
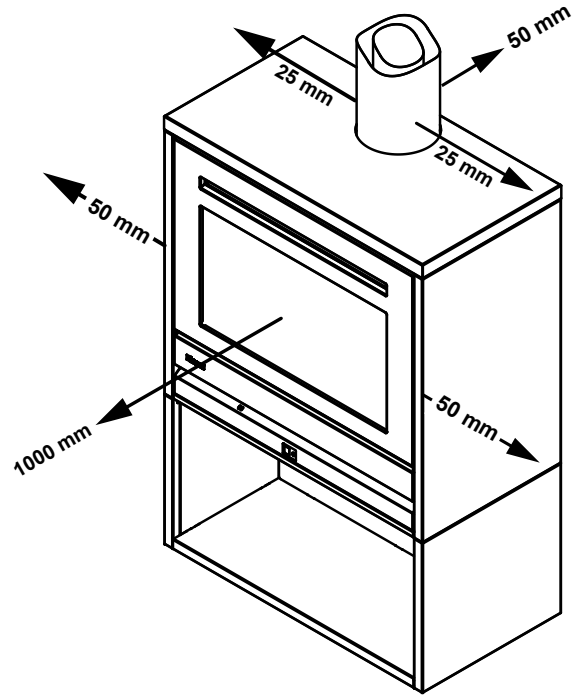

FLOORING AND HEARTH MATERIAL SELECTION

The temperature in front of the fire (200-350 mm x 400 mm wide) can reach up to 40 °C above ambient, therefore material selection is important. Some guidelines are detailed below. For example, vinyl planks are often only rated for ambient temperatures. Consequently, the heater would not be suitable for installation directly on that flooring type.

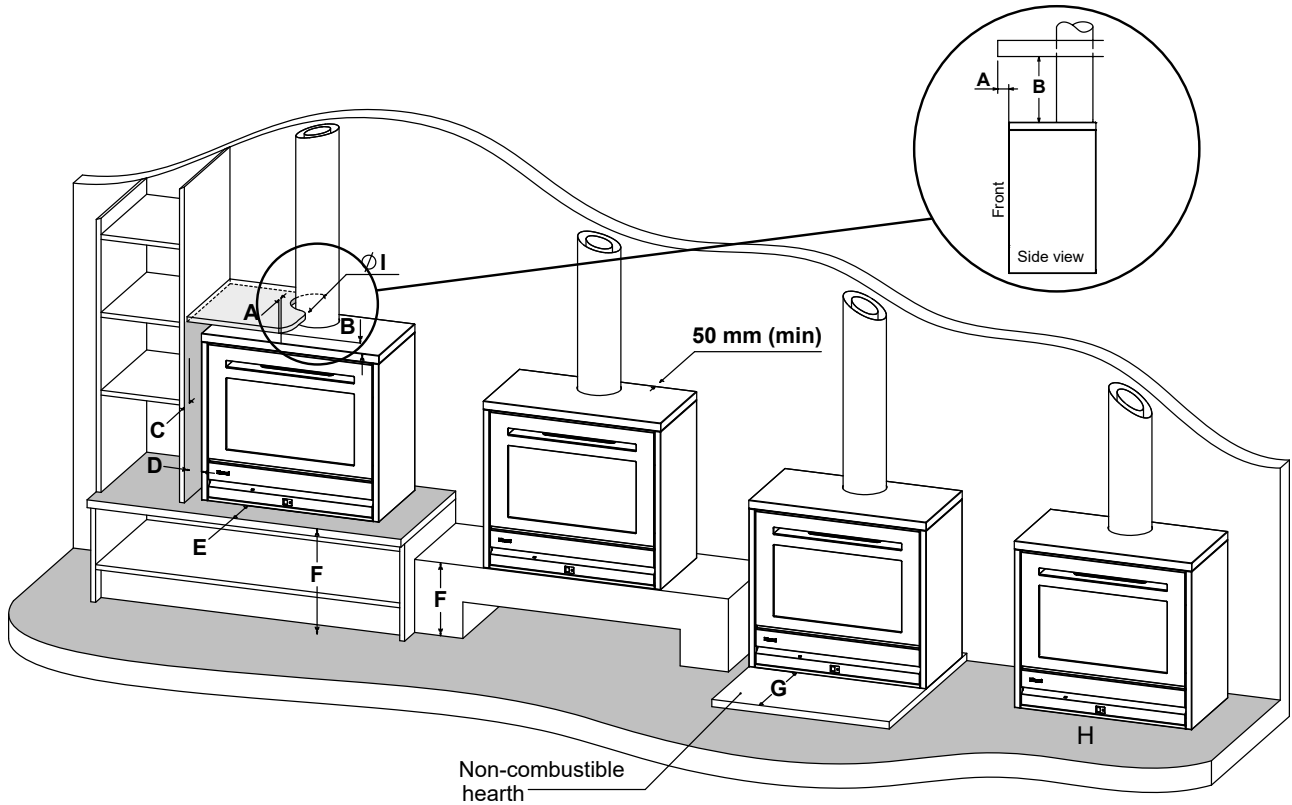

Dim.	Description	Non-combustible materials or materials rated to 60 °C or higher above ambient	Materials rated to a maximum of 50 °C above ambient	Unrated materials, anything up to 20 °C above ambient
A	Overhang	No restriction as long as materials within 400 mm to the side (D) are of the same rating	<ul style="list-style-type: none"> Not suitable if B is under 250 mm No restrictions if B is greater than 1000 mm If B is 300-1000, refer page 9 	
B	Clearance above	50 mm min.	100 mm min.	200 mm min
C	Side overhang	No restrictions	No restrictions if D is greater than 400 mm	
D	Side clearance	50 mm min.	50 mm min.	100 mm min.
E	In front	No restrictions	150 mm max.	100 mm max.
F	Clearance to floor	No restrictions	150 mm min.	240 mm min.
G	Hearth depth	No restrictions	400 mm min. of non-combustible material	450 mm min. of non-combustible material
H	Directly on floor	No restrictions	Not suitable for heat sensitive materials	
I	Flue clearance	25 mm min.	50 mm min.	

The shaded cells above denote measurements A, B, C, and D. These figures are dependent on each other and the type of installation. These dimensions may be refined with some specific calculations. These calculations are based on figures obtained during in-house temperature testing. For more information refer to the next page.

Even if a material is rated above 60 °C it may still be subject to deterioration when exposed to heat cycles. Always refer to the materials supplier for suitability. The temperatures given assume the heater is operating in a room temperature of 25 °C or less. Operation in higher ambient temperatures may result in higher surface temperatures.



RINNAI DOES NOT TAKE ANY RESPONSIBILITY FOR ANY DAMAGE OCCURRING TO ANY ITEMS INSTALLED IN THE VICINITY OF THE HEATER.

MATERIAL SELECTION CALCULATIONS

The following provides further detail on the relationship between various clearance dimensions and gives examples of what specific dimensions may be if other clearances are adjusted.

Dim.	Description	Material temperature rated above ambient	
		Materials rated to a max. of 50 °C	Unrated materials, up to a max. of 20 °C
A	Overhang	Not suitable if B is under 250 mm No restrictions if B is greater than 1000 mm <u>If B is 300-1000 mm then the calculation is: $A = B - 250$</u> If B = 300 and A = 300-250, the overhang can be 50 mm max. If B = 350 and A = 350-250, the overhang can be 100 mm max. If B = 400 and A = 400-250, the overhang can be 150 mm max. If B = 450 and A = 450-250, the overhang can be 200 mm max.	
B	Clearance above	100 mm min. If recessed with an overhang $B = A + 250$	200 mm min. If recessed with an overhang $B = A + 250$
		If A = 50 and B = 50+250, clearance above needs to be 300 mm min. If A = 100 and B = 100+250, clearance above needs to be 350 mm min. If A = 150 and B = 150+250, clearance above needs to be 400 mm min. If A = 200 and B = 200+250, clearance above needs to be 450 mm min.	
C	Side overhang	No restrictions if D is greater than 400 mm <u>If D is less than 400 mm, $C = D + 50$</u> C = 50 +50, side overhang 100 mm max. C = 100+50, side overhang 150 mm max. C = 150+50, side overhang 200 mm max. C = 200+50, side overhang 250 mm max.	No restrictions if D is greater than 400 mm <u>If D is less than 400 mm, $C = D$</u> C = 50, side overhang 50 mm max. C = 100, side overhang 100 mm max. C = 150, side overhang 150 mm max. C = 200, side overhang 200 mm max.
D	Side clearance	50 mm min. No restrictions if D is greater than 400 mm <u>If D is less than 400mm = $C - 50$</u> 150-50, side clearance must be 100 mm min. 200-50, side clearance must be 150 mm min. 250-50, side clearance must be 200 mm min. 300-50, side clearance must be 250 mm min. 350-50, side clearance must be 300 mm min. 400-50, side clearance must be 350 mm min.	100 mm min. No restrictions if D is greater than 400 mm <u>If D is less than 400mm = C</u> 150, side clearance must be 150 mm min. 200, side clearance must be 200 mm min. 250, side clearance must be 250 mm min. 300, side clearance must be 300 mm min. 350, side clearance must be 350 mm min. 400, side clearance must be 400 mm min.

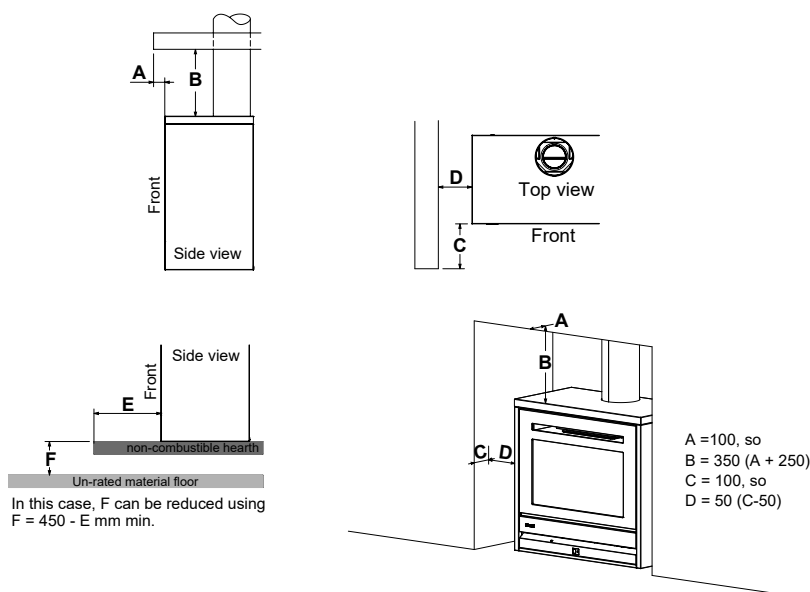

CAUTION Please note the recommended clearances in the tables above. Wall surface temperature may be elevated directly above the appliance and may discolour paint finishes or distort vinyl coverings.

INSTALLATION EXAMPLES

Freestander installed on a combustible platform.

Depending on material, refer table on page 8. The platform could extend 150 mm or 100 mm maximum in front of the fire. This is dimension E in the table.

The height of the platform would need to be at least 150 mm or 240 mm high. This is dimension F in the table.



Freestander installed on a non-combustible floating hearth.

Only requirement for non-combustible material is a 50 mm clearance from the back of the fire to the wall.

If the material is rated 50 °C or less (above ambient) then:

- 50 mm clearance from the back of the fire to the wall and 50 mm side and top clearance.
- In front, hearth could extend 100 mm or 150 mm maximum, this is dimension E in the table on page 8.



Freestander with plinth base installed on wooden floor.

Using the table on the page 8 there would be no restrictions except a 50 mm clearance from the back of the fire to the wall. The plinth automatically gives the 240 mm minimum clearance from the bottom of the fire to the wooden flooring—this is dimension F in the table.



Freestander installed in an alcove.

If all materials are non-combustible then the only restrictions are:

- 50 mm clearance from the back of the fire to the wall
- 500 mm minimum clearance above and to the sides, and that the material above the fire is the same as the material to the sides of the fire.
- The flue requires a 25 mm clearance.

If the material is rated 50 degrees Celsius or below then the parameters in the table and the material selection calculations, on the previous pages apply.



SUPPLY CONNECTIONS

GAS SUPPLY



Gas pipe sizing **MUST** consider the gas input to this appliance as well as all other gas appliances in the premises. The gas meter and regulator **MUST** be specified for the total gas rate.

A suitable sizing chart such as the one in AS/NZS 5601 should be used.

The use of rubber hose for any gas connection to a fixed appliance is **NOT** authorised by the manufacturer.



Confirm correct gas type (see labels located on top or rear panels). Refer to local gas authority for confirmation of gas type if you are in doubt.

Installation of Consumer Piping

The gas supply position will vary slightly based on whether a SS850 Freestander has been ordered or with a cabinet or plinth. Refer to the installation diagrams on page 12, and 17 to 20 for more information on appropriate service supply positions.



The gas and power supply can be brought in through the base of the fire.

Once the consumer piping has been terminated the supplied flexible gas connection may then be fitted.

Gas Connection

Firmly grasp the stainless steel flexi pipe ① and bend to line up with the gas control valve inlet ②, then attach the

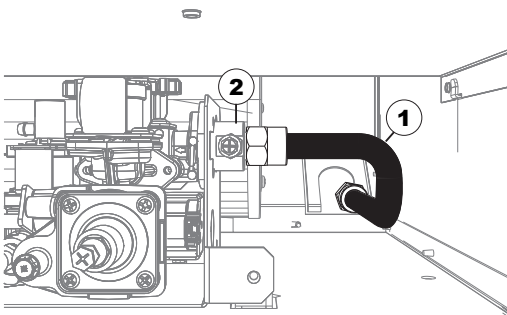

pipe to the gas control valve and tighten.

Purging Gas Supply

Foreign materials and debris such as swarf, filings, etc. **MUST** be purged/removed from the gas supply, failure to do so may cause damage to the gas control valve causing it to malfunction.

Leak Testing the Connection

With the supplied plug inserted into the end of the flexible gas connection, leak test all joints.





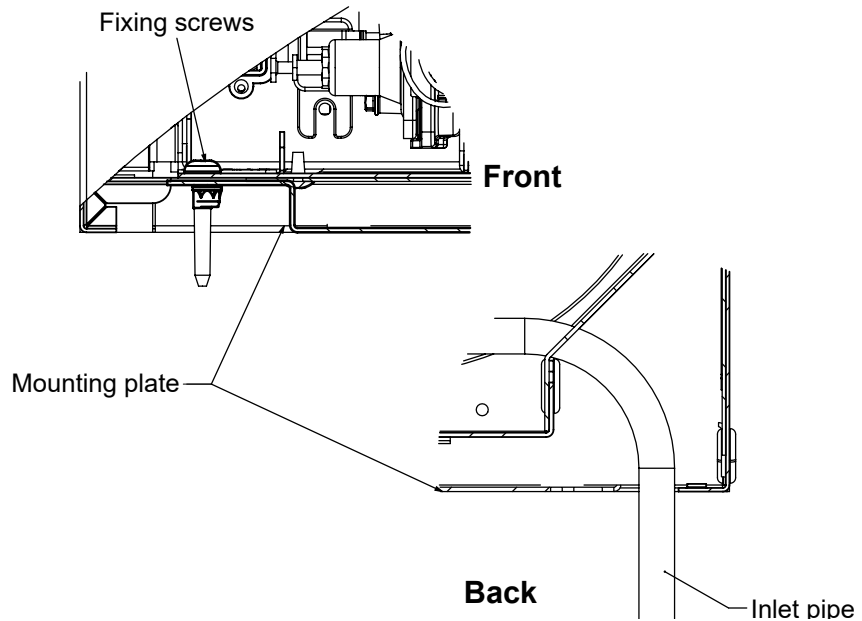
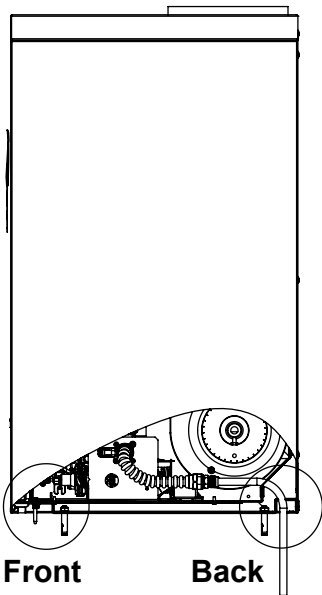
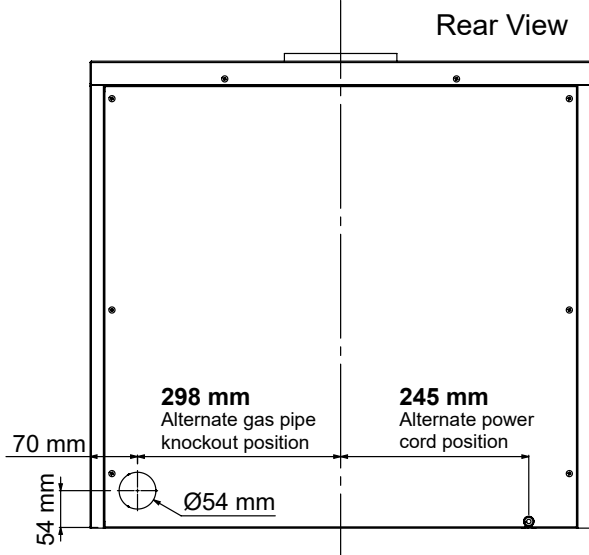
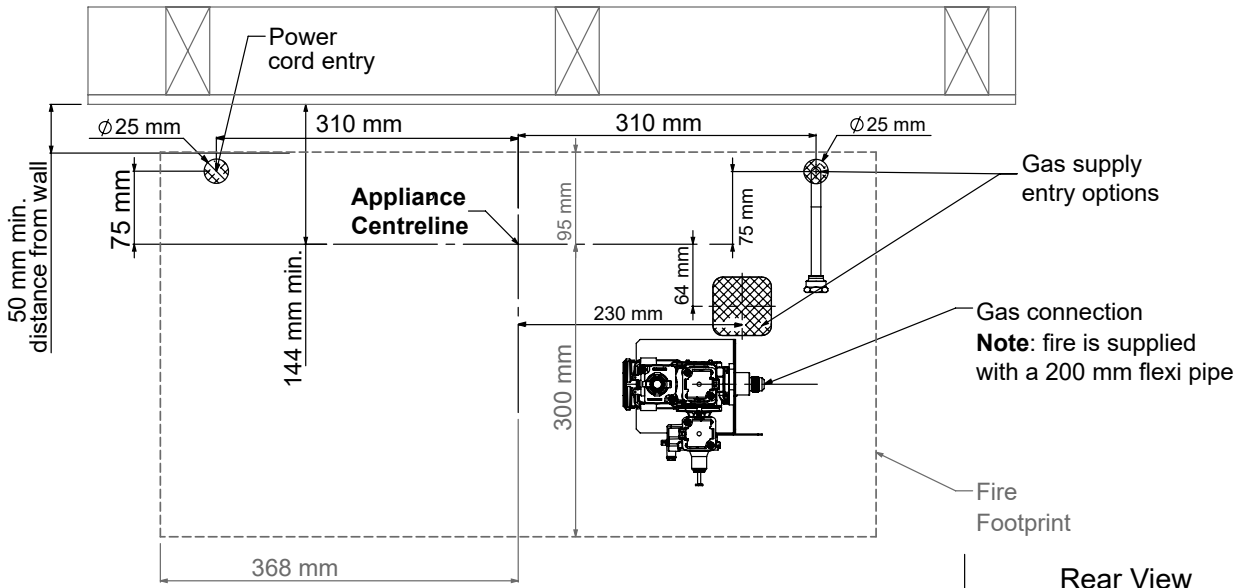

Use a soapy solution to test all gas connections. If a leak is present bubbles will form. When finished remove residue with a rag. Prevent soapy solution from contacting electrical components.

GAS SUPPLY LOCATIONS



ELECTRICAL SUPPLY

HAZARDOUS VOLTAGE.
Risk of Electrical Shock.

 Disconnect all sources of supply prior to servicing
 

Socket Outlet

Where a power point is used it **MUST** be 230 V, rated at 10A and **MUST** be earthed. This power point **MUST NOT** be located above the heater. Alternatively the appliance can be direct wired if the power supply is to be concealed.

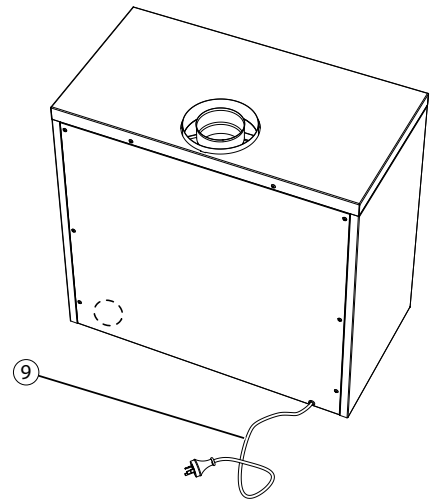
The heater engine is fitted with a 1.5 m power cord and three pin plug ⑨ which exits the appliance from the rear panel at the lower right when viewed from the rear.



Direct Wired Installations

Alternatively the appliance can be direct wired with an isolation switch if so required.



A qualified electrician will need to be consulted where a direct wired installation is required. Any such installation **MUST** comply with the requirements of AS/NZS 5601, AS/NZS 3000 and any other relevant local regulations.



The power cord is not fire rated and **MUST NOT** come into contact with the unit. If the power cord is damaged, it **MUST** be replaced by a licensed tradesperson. This must be a genuine replacement part available from Rinnai.

INSTALLATION

FREESTANDER INSTALLATION

Unpack the fire.

1. Remove the frame (two screws). (A)
2. Remove the control panel (two screws) and unplug the ON/OFF switch. (B)

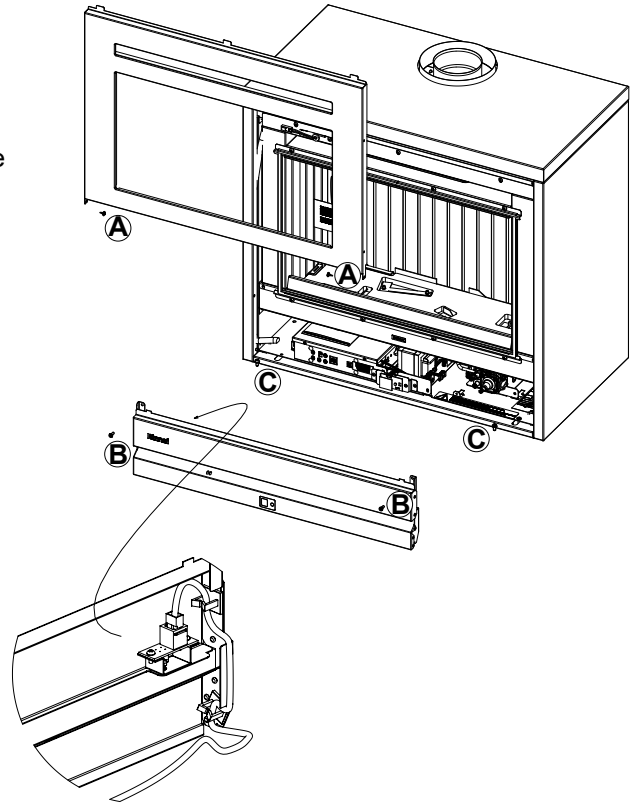

Prepare location of gas and power.

1. Mark the position of the flue centreline on the floor. Note the minimum distance from the wall (50 mm).
2. The gas and power supply can be brought in through the base of the fire. The pipe/power cord must enter within the shaded area shown on page 12. The hole must not extend beyond the fire footprint. If the power is to be brought in from the back, there is a knockout in the bottom right corner (viewed from the back of the fire) of the back panel that can be removed with pliers. There is also a knockout for the gas on the back panel.

Check the flue configuration.

Check the flue configuration. Check if the aeration plates need adjusting or additional plates that may need to be added. Refer to page 15 for more information.

Reassemble and secure.

Follow the reverse steps for unpacking the fire. Secure the fire to floor using mounting holes (C)

Install flue system.

Install coaxial flue system. Refer to pages 24 through 29.

Complete gas connection.

Install gas connection. Refer page 11.

Install the burn media and commission.

Install the burn media, refer page 22. Refit the glass and the inner and outer frames.

AERATION PLATES

The SS850 comes with two aeration plates that are factory fitted, in a position for flues between 3-5.5 m, refer image below. There are a further two aeration plates supplied in the accessory pack (for flues 5.6-8 m).

To control flame lift and efficiency on long flues (anything over 3 m) it is important the aeration plates are configured correctly. Refer chart below.

To maintain balance within the combustion chamber, it is important to fit the plates equally to both sides. The chart below shows the plates required for any given flue length. Fitting more plates than shown may have a detrimental effect on startup performance, especially in very cold areas.

If the flue length is less than 3 m the factory fitted aeration plates need to be removed.



Avoid sliding the flue adapter assembly around too much when fitting. This may cause the gaskets to be incorrectly sealed.

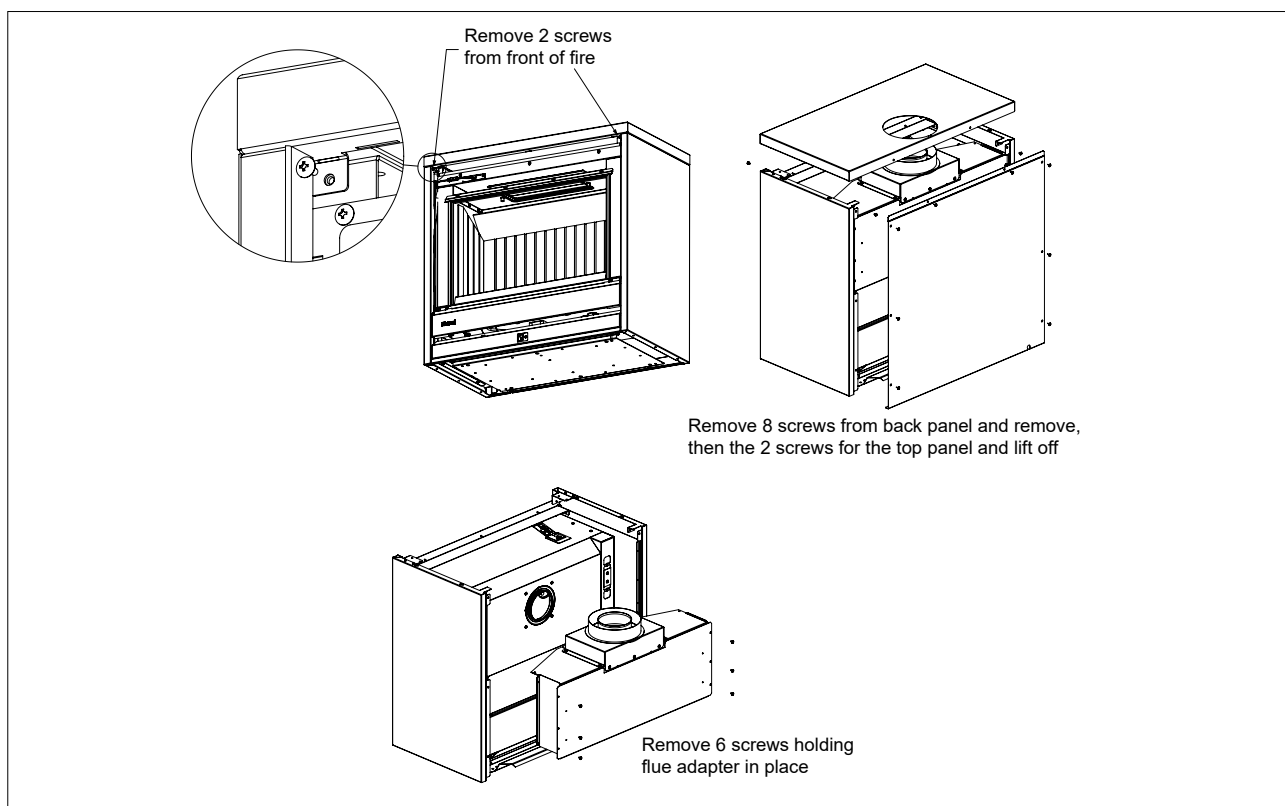

Aeration Plate Configuration			
Vertical flue height	< 3 m	3 - 5.5 m	5.6-8 m
Action required	Remove factory fitted aeration plates.	Factory default.	Fit additional plates supplied in accessory pack.

CABINET INSTALLATION

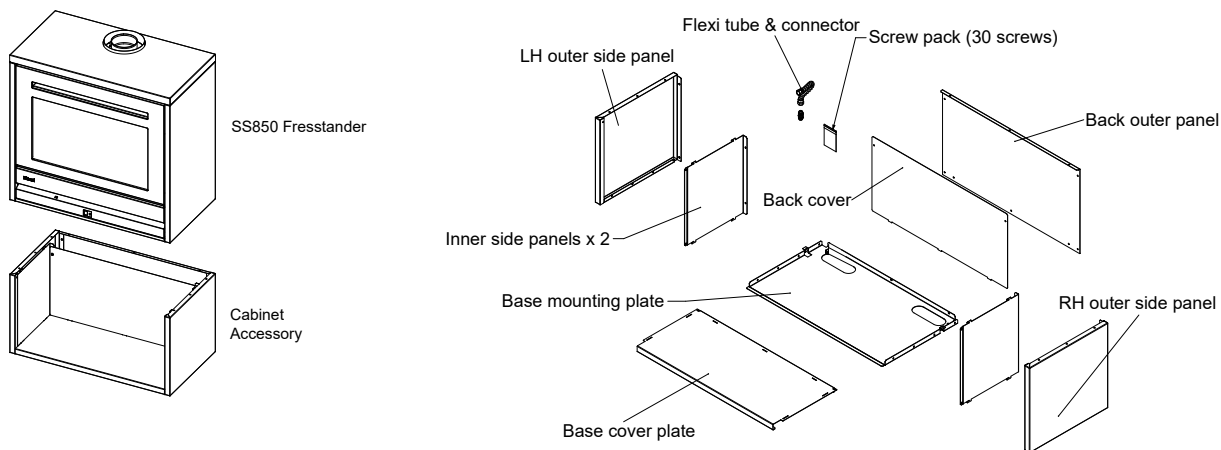

There are two ways to install the cabinet to the SS850 Freestanding:

Complete assembly.

1. Prepare mounting area for fixing and services.
2. Lay the fire on its back.
3. Fix the partially assembled cabinet to the fire.
4. Fix the fire in place and connect power and gas supplies.

Build up (requires two people).

1. Prepare mounting area for fixing, power and gas supplies.
2. Fix partially assembled cabinet base to the floor.
3. Lift fire onto the cabinet and fix together.
4. Connect power and gas supplies.

Mounting area.

1. Mark the flue centre on the floor.
2. Fold the base panel locator tabs up as shown on the next page.
3. Check there is sufficient timber under the screw mounting holes to provide adequate retention. If necessary, underfloor blocking may be required. A minimum of four screws, two front and back, are required.

Do not fix the fire in place yet unless there is sufficient room behind the fire to get a screwdriver in to fix the back panel in place.

Make the cabinet.

Working on a flat surface, assemble the outer cabinet panels as shown on the next page. Make sure the cabinet is square and that the top surfaces are flush with each other.

Fix the cabinet to the fire and check aeration.

Unpack the fire as per instructions on page 14. To make the fire lighter and easier to manage, remove the glass front, log set, and ceramic panels from the inside of the combustion chamber.

Before doing anything else, check the aeration plate setting, refer previous page.

Fix the cabinet (make sure panels are flush, especially on the front and sides) to the fire, either:

- Lay the fire on its back and fit the cabinet using nine screws, stand it up and fix in place, or
- Fix the cabinet to the floor, fit the cube onto the cabinet, and fix in place.

Connect services and commission.

Before adding the cabinet cover panels (see next page), connect the power and gas. There is a second stainless steel flexi tube connector supplied with the cabinet kit to make connection easier. Commission as per the commissioning instructions on page 30.

CABINET INSTALLATION CONT.

Fit the base cover panel

Ensure the lower front edge of the panel is hooked under the front edge of the base mounting panel as shown below. The front faces **MUST** be flush.

Fix the panels in place using two screws.

Fit side panel covers

Fit tabs into slots. Slide panels forward so the leading edge is behind the side panel. Fix in place, one screw per side.

Fit back panel

Fit tabs into slots. Fix in place with two screws.

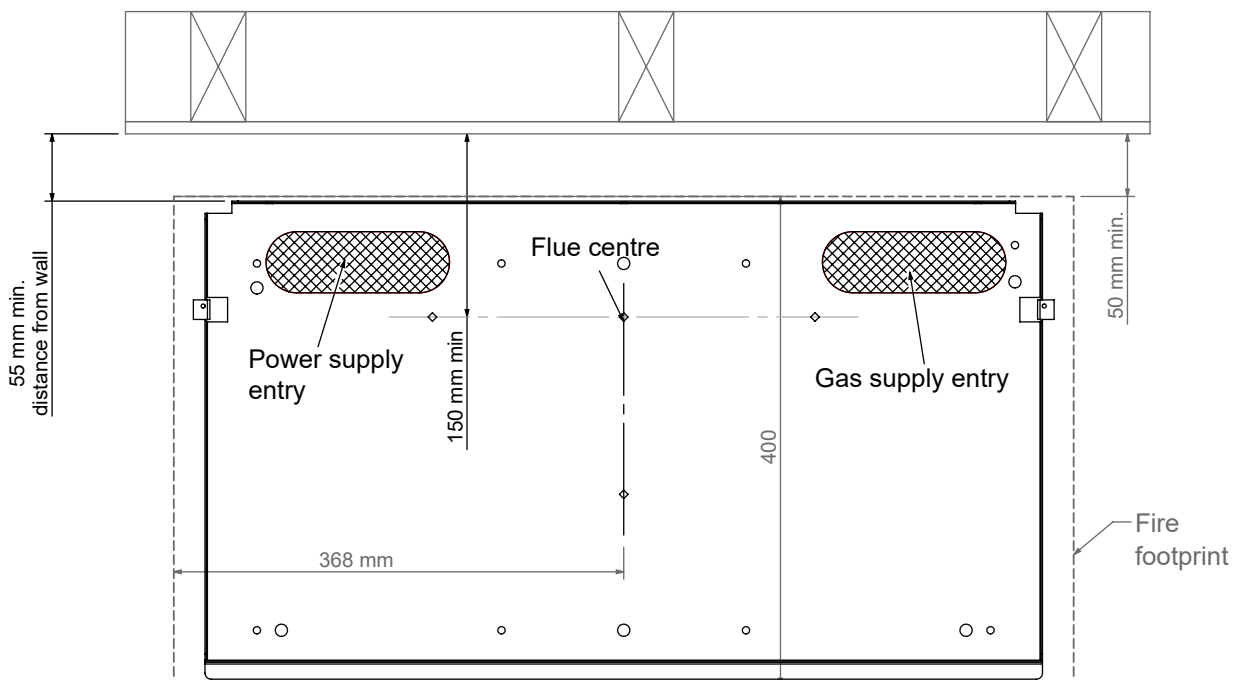
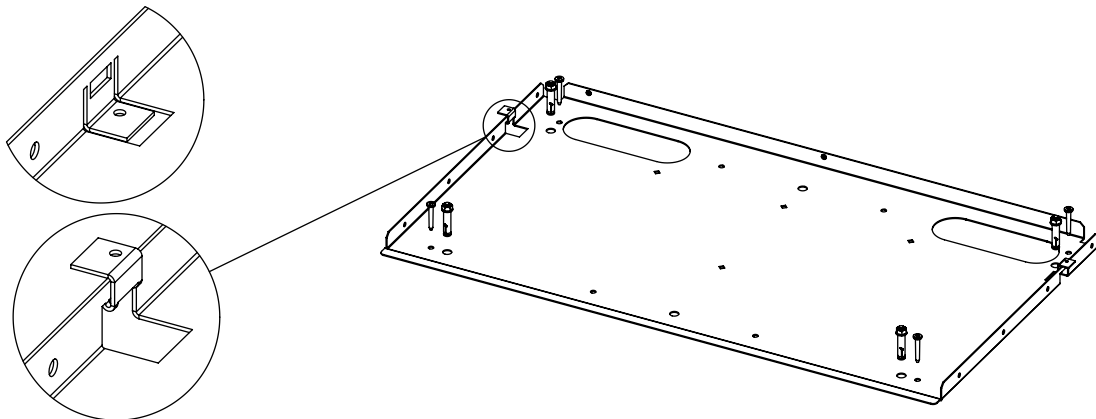

Cabinet assembly

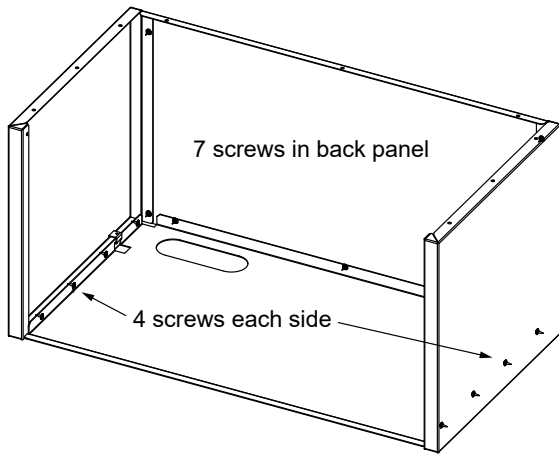

Fixing the fire to the cabinet

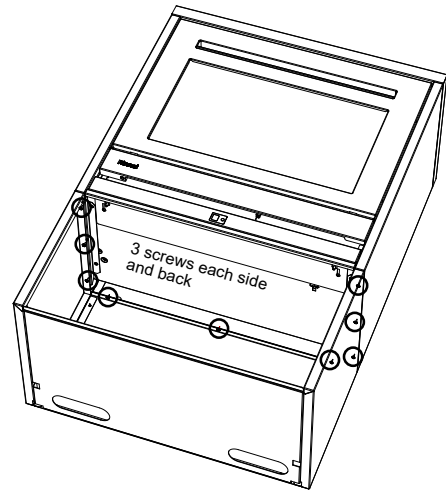

Power and gas supply

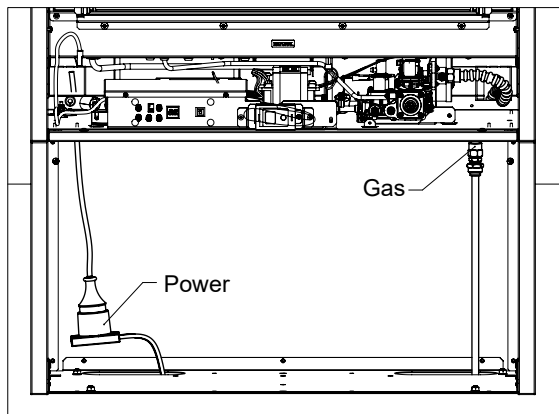

Fitting base cover panel

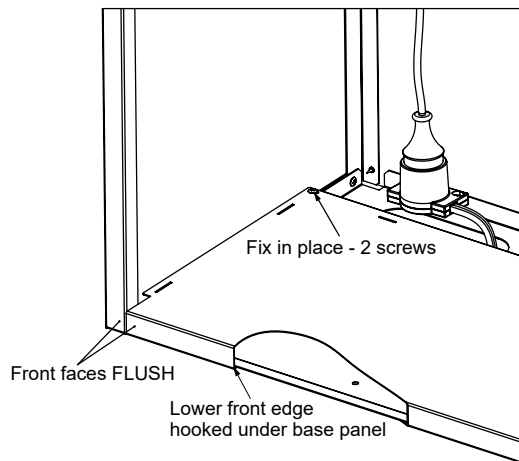

Fit side panel covers

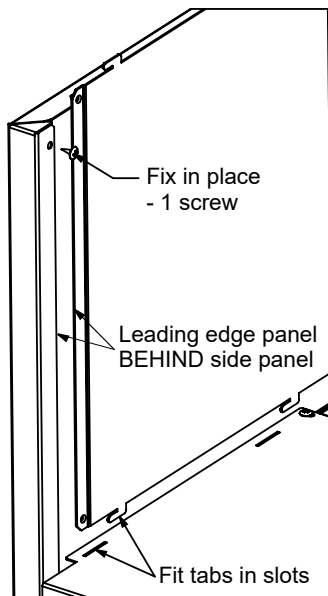

Fit back panel

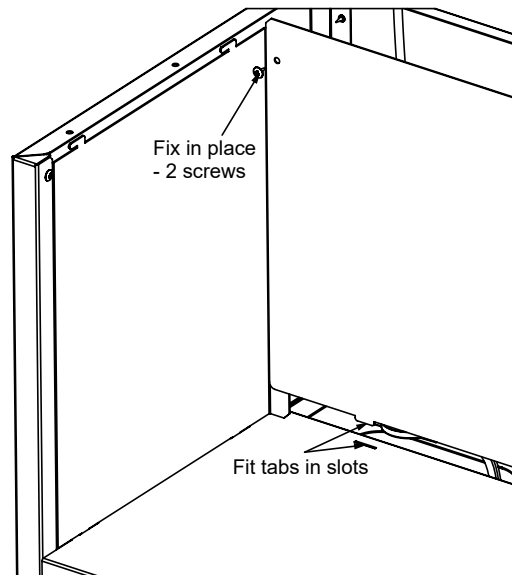

PLINTH INSTALLATION

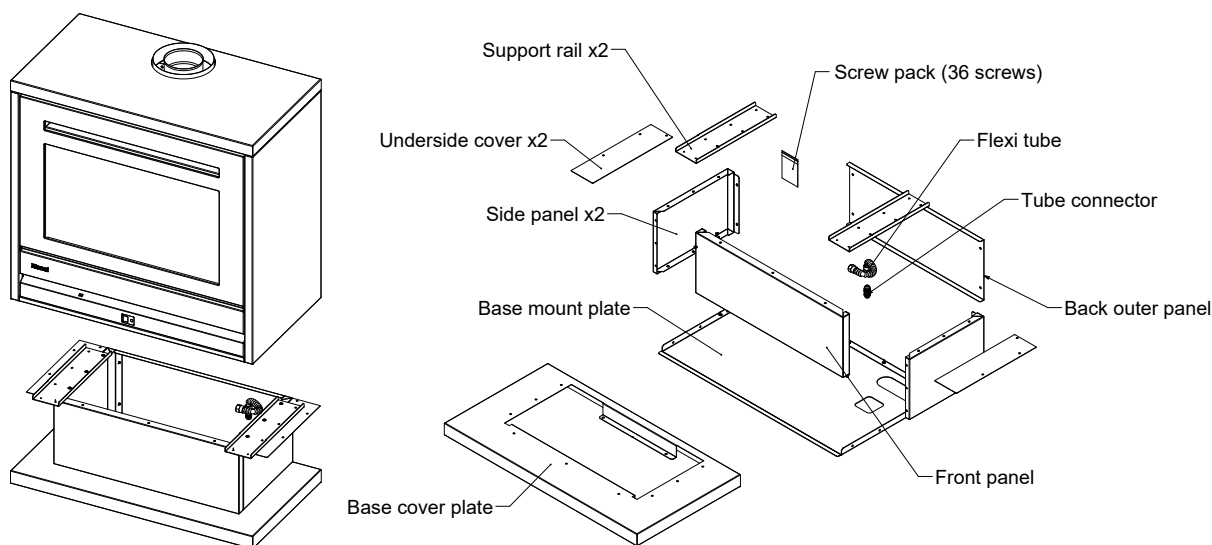

Mounting area and mounting plate

1. Mark the flue centre on the floor.
2. Place the base mount panel on the floor and line up with the centre marks, and mark the area for power and gas to enter. The alternate power and gas options shown in the cube installation also apply here.
3. Check there is sufficient timber under the screw mounting holes to provide adequate retention. If necessary, underfloor blocking may be required. A minimum of four screws, two front and back, are required.

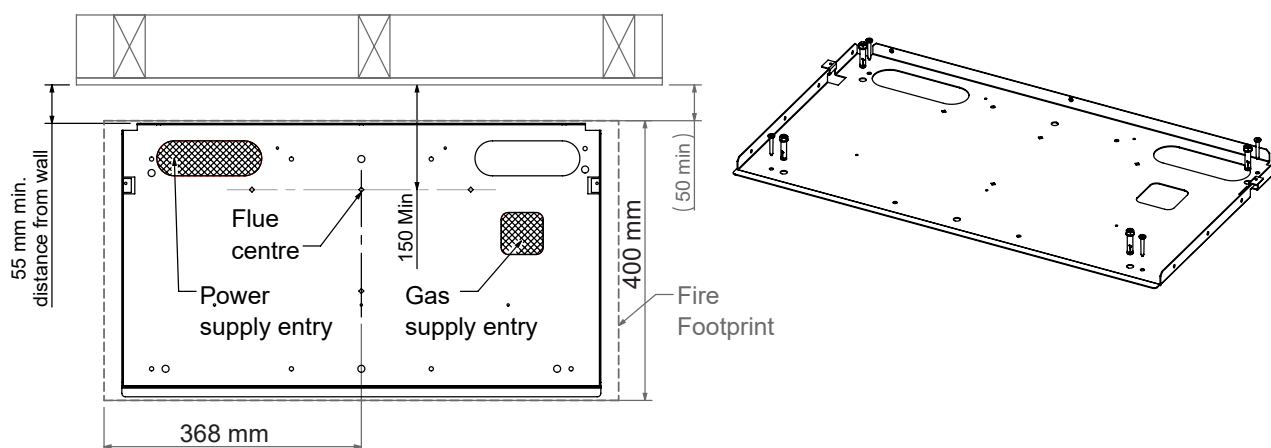

Prepare Services

For best results the gas and power can be supplied through the plinth and into the base of the fire. The power will need to be hard wired.

Bring enough cable through the floor to reach at least 100 mm above the top of the plinth. Bring the gas supply through to within approximately 50 mm of the top of the plinth, flare the pipe, and fit the supplied flexi tube. This should be leak tested now as access through the back panel is limited once the fire is installed. The alternative is to drill a hole in the back of the fire for the gas supply and to remove the notch for the power cord.

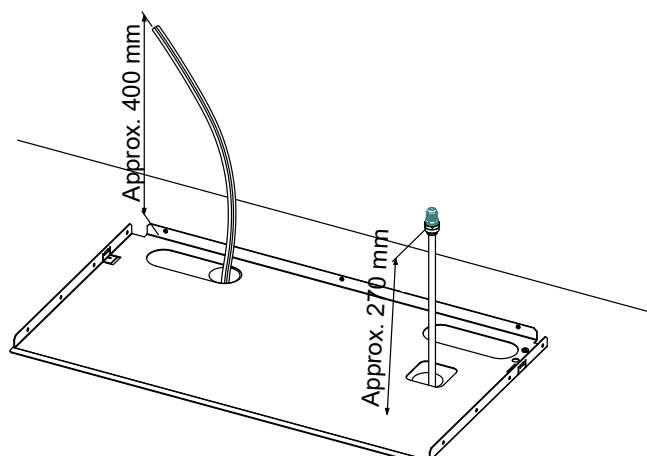

Assemble outer plinth panels

Working on a flat surface assemble the outer plinth panels as shown. Take care to ensure the plinth is square and that the top surfaces are flush with each other.

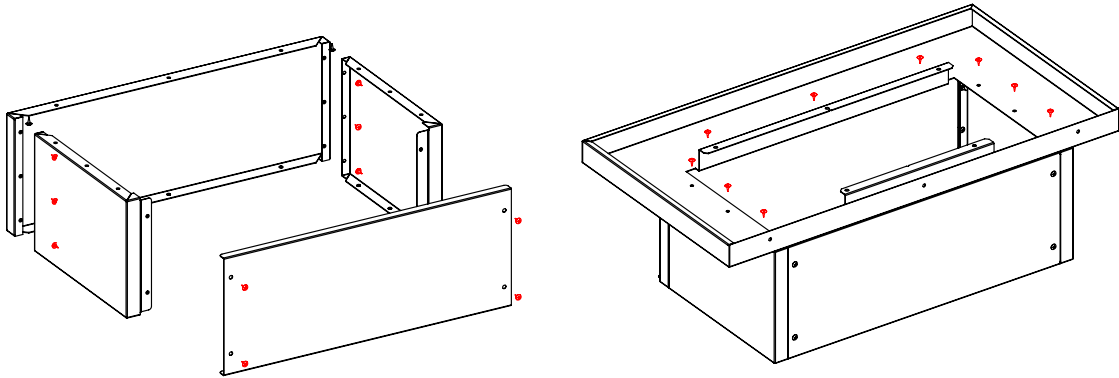

Fit panels to the base mounting plate

Fit the plinth to the base mounting plate by lifting the back edge of the plinth and sliding the front edge under the front lip of the base plate, then setting the edge back down. Hold in place with three screws.

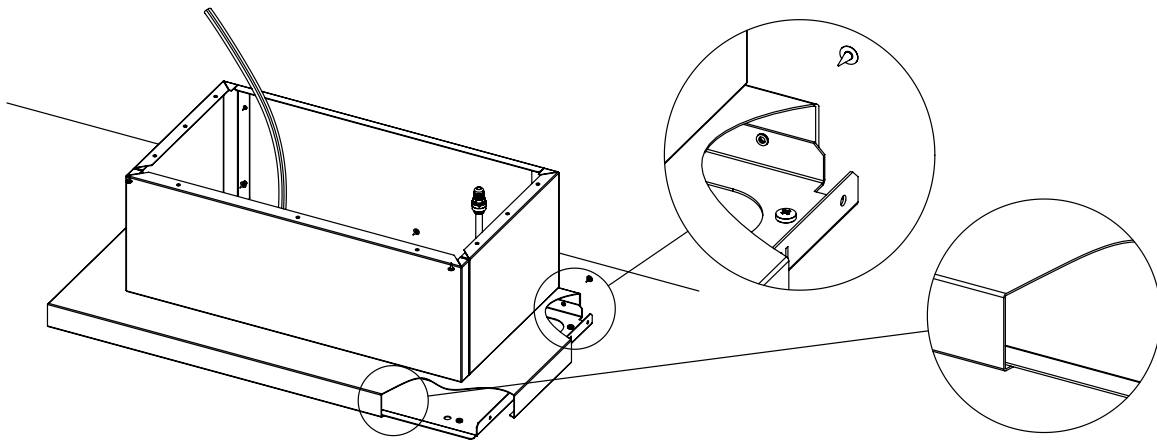

Fix fire base plate to plinth

Fix the fire base plate to the top of the plinth assembly using the stiffening rails as shown. Fit the second flexi pipe supplied with the fire if required.

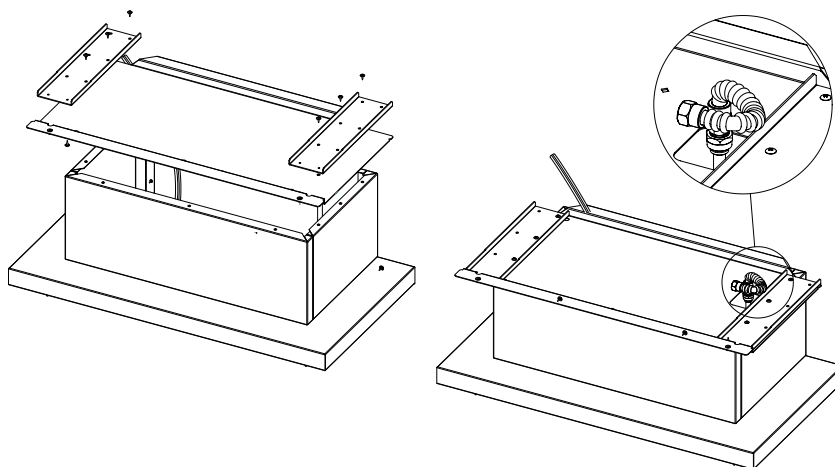

Check aeration setting

Check that the correct aeration shutter plates are fitted, (refer to page 15). It is still possible to change the aeration setting once the fire is installed, however it is much easier to do this beforehand.

Fit the fire to the plinth

Lift the fire onto the plinth and feed the gas supply tube through the hole in the back corner. The fire needs to be set approximately 20 mm back from the plinth, then slip forward so the bottom edge of the fire back panel sits under the back edge of the fire mounting plate.

Fix in place with 2 x M5 screws through the front edge of the fire, circled below.

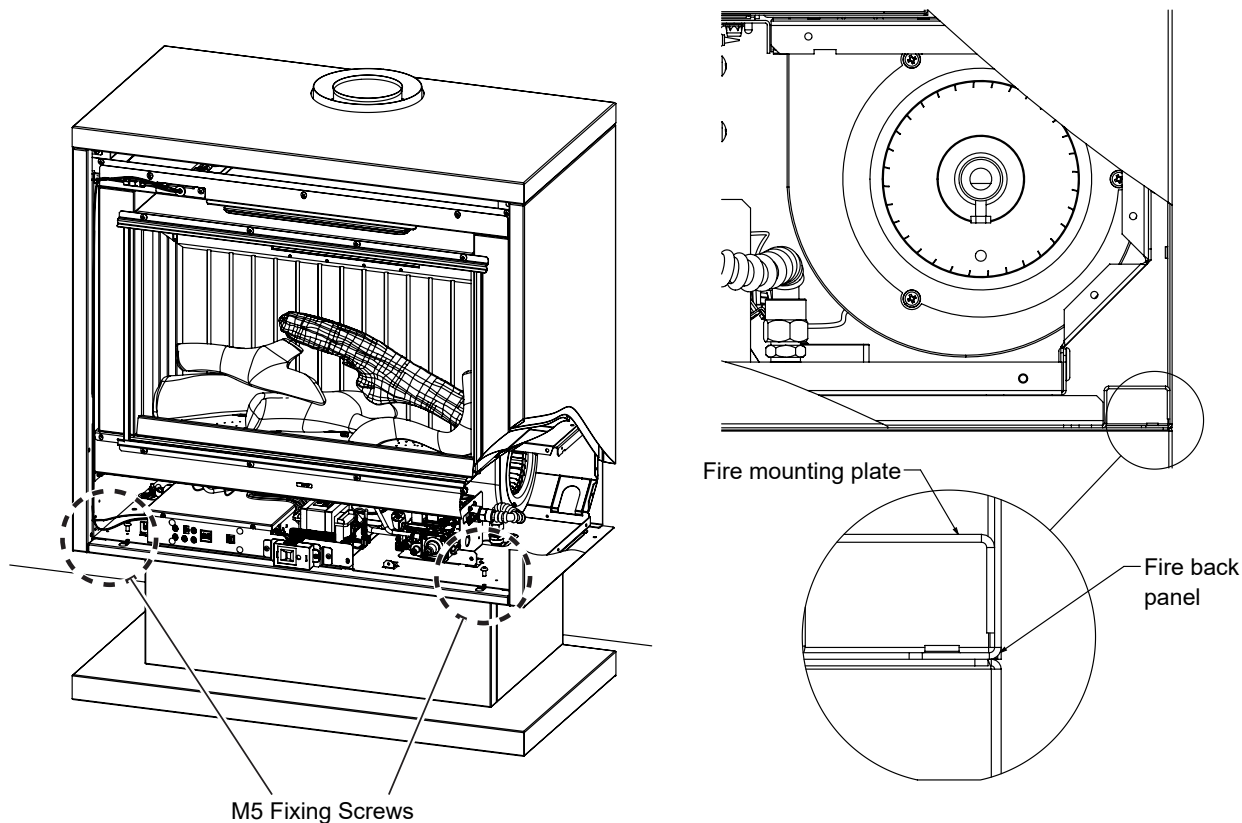

Connect services and commission

Connect the power and gas. Fit the underside covers, and commission as per the commissioning instructions on page 30.

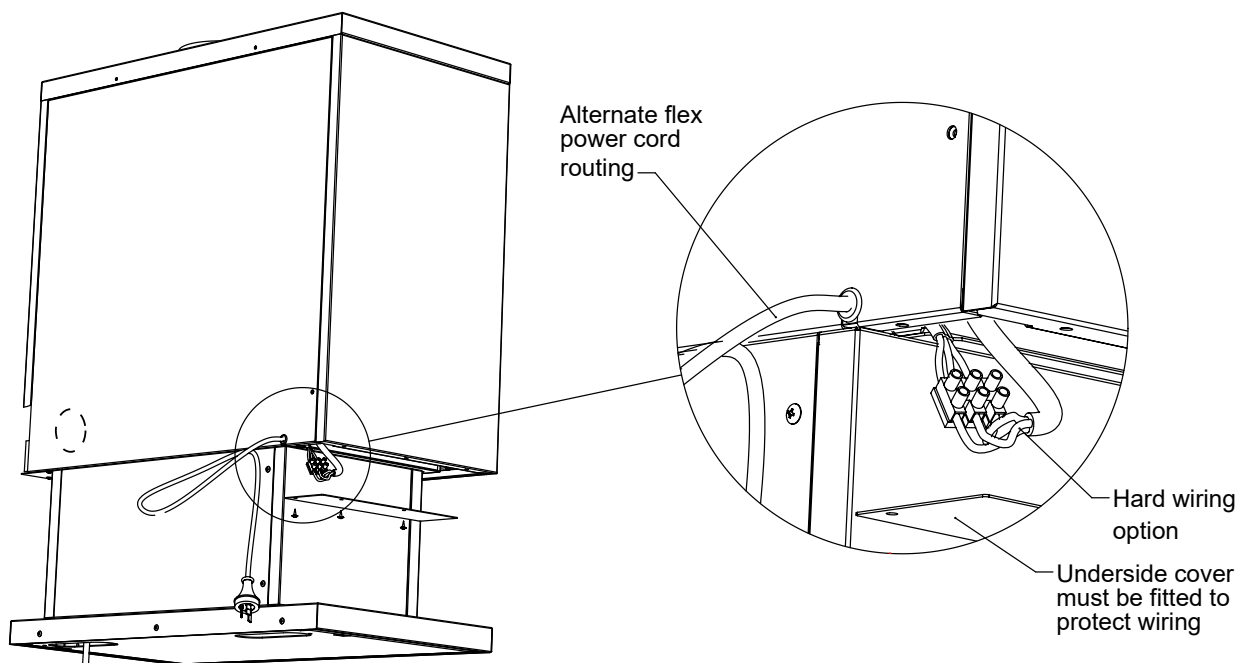

BURNER MEDIA INSTALLATION

BURNER MEDIA PLACEMENT

The granule pack and log set, consisting of five logs, comes packaged inside the appliance. Use extreme care when handling the logs, they are fragile and will damage easily. The unit must never be used with broken logs or other burn media.

Experience has shown that the majority of performance problems are caused by burn media being installed incorrectly. Incorrect placement can create carbon build-up and affect performance. Please take the time to read and follow these instructions as malfunctioning due to incorrect placement is not covered by warranty.

The granules as well as being added to create a more realistic log effect (they diffuse the gas flames) also assist in soot prevention and are **CRITICAL** to the correct operation of the fire. Never pour the granules directly from the pack as dust particles and the granules may block the burner ports.



During the initial burning in period of approximately 2 hours, some minor smoke and smell may be experienced. During this period the heater should be operated on High and the space being heated should be well ventilated. It may take up to 20 minutes of operation for the logs to achieve their full flame pattern and glow.

Malfunctions due to incorrect burn media placement are **NOT** covered by warranty.

The appliance **MUST NEVER** be used with other burn media or burn media that is damaged.



Arrange the rest of the logs and place 31 granules around the burner ports (not directly over) as shown below. You will have granules left over.

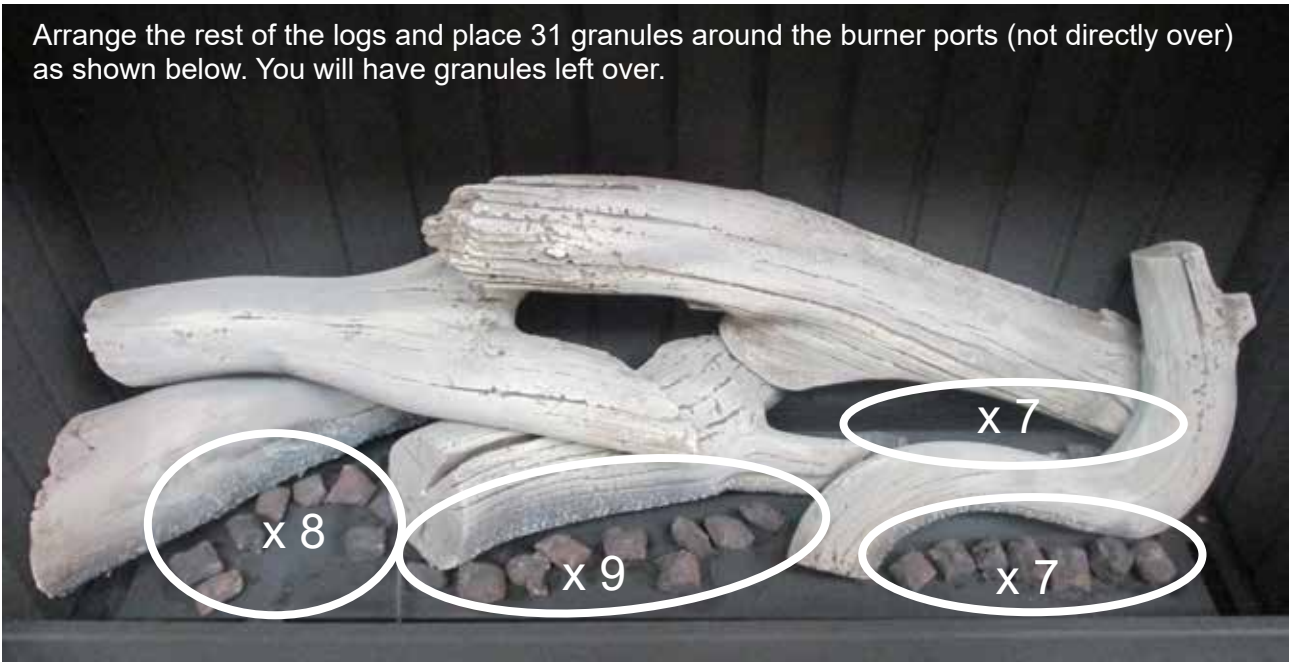

If there are some abnormally long streaky flames, then readjust the granule position around the burner holes until the flames have improved.



FLUEING

GENERAL FLUEING GUIDELINES



The following diagrams illustrate the flue installation options that are available for the Rinnai SS850 Heaters. **ONLY** the genuine Rinnai flue is certified as part of the installation requirements.

ONLY an authorised person **MUST** install, service and remove the Rinnai SS850 heater and flue system.

Only the flue system components described in this Manual are suitable and **MUST** be used.

Components that are not described in that manual, whether manufactured by Rinnai or otherwise, are **NOT** compatible and **MUST NOT** be used.

Rinnai appliance warranty conditions may be voided if non Rinnai Flue Components are fitted.

AS/NZS 5601 “GAS INSTALLATIONS” requires that flue components be supported independently of the appliance.

Independently supported flue

The weight of the flue system **MUST NOT** be supported by the appliance. It **MUST** be independently supported.

Supporting the flue is usually completed during the framing stage with flue supports or straps within the cavity. Wall straps have been included in the Rinnai coaxial vertical flue kit. Elbow straps are also available as a separate component to prevent excess weight on the flue elbow (if used).

Flue terminal locations

Flue terminals must be compliant with the flue terminal locations shown in AS/NZS 5601.1.

The flue cannot terminate under a floor or in a roof space.

Flue cowl clearance

To ensure products of combustion are cleared, adequate clearance from the building is required.

The flue cowl should have a 500 mm clearance from any part of the building. This also applies to steep and pitched roofs where the flue cowl should be 500 mm clear of the ridge line.

An adequate flow of fresh air must exist around the flue cowl following installation.

Minimum clearances are shown in AS/NS 5601.1

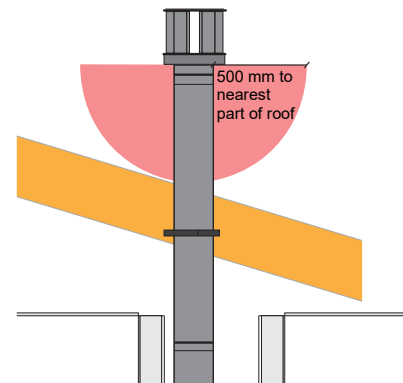

Flashings

Flashings are not included in the flue kits. Flashings must comply with plumbing regulation, this is the responsibility of the installer.

Shared flues



Gas appliances must not be connected to a chimney or flue serving a separate flue burning appliance.

FREESTANDING FLUEING OPTIONS

Minimum flue length

This is required to ensure adequate draw and to prevent spill-back of combustion products, which can cause the safety sensors to shut down the fire.

- Min. vertical length: 3 m
- Min. flue length before any bends or offsets: 900 mm (or one length of flue)

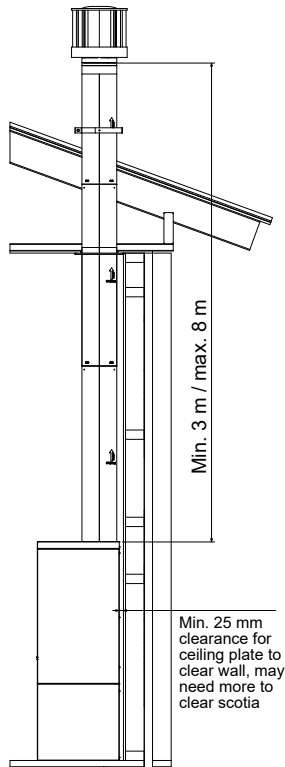

Freestanding straight vertical

For this option there is a standard single storey vertical flue kit 3.6 m, refer page 27. If flueing is longer individual flue components can be purchased.

Visible flue sections are powder coated black.

Maximum flue length

The maximum flue length is determined by what the product has been tested, verified, and certified to.

- Max. flue length: 8 m
- Max. number of bends: 2 x 45°, or 2 x 90°

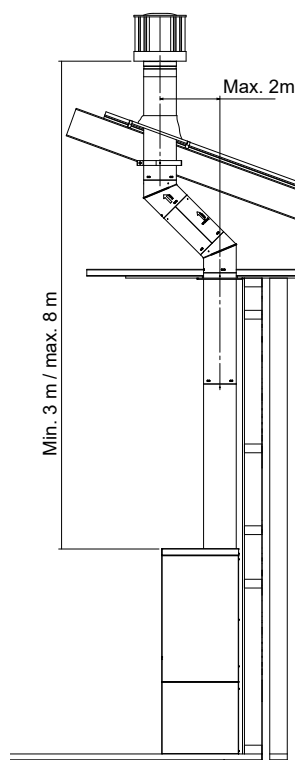

Freestanding vertical offset

This option uses 45° bends to offset obstructions in the roof space.

Individual flue components need to be purchased for this option.

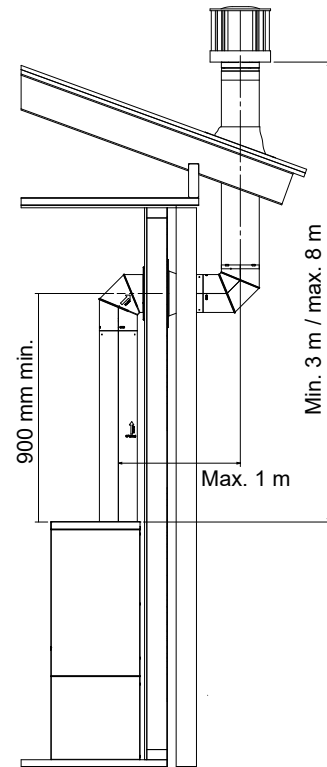

Freestanding vertical with a 90° offset wall penetration

For instances where there may be another room above or vertical obstructions. There is also an option to penetrate the wall with 45° bends.

Individual flue components need to be purchased for this option.

GENERAL FLUE ASSEMBLY LAYOUT AND CLEARANCE REQUIREMENTS

The flue is built from the bottom up. The black sections of the flue are supported by the fire in the event of the fire needing to be removed for maintenance, servicing etc. As the pipes are interlocking, use of sealant is optional.



For all flue options please ensure a minimum clearance of 500 mm from the roof to the underside of the flue cowl, as per AS/NS5601.1 6.9.2

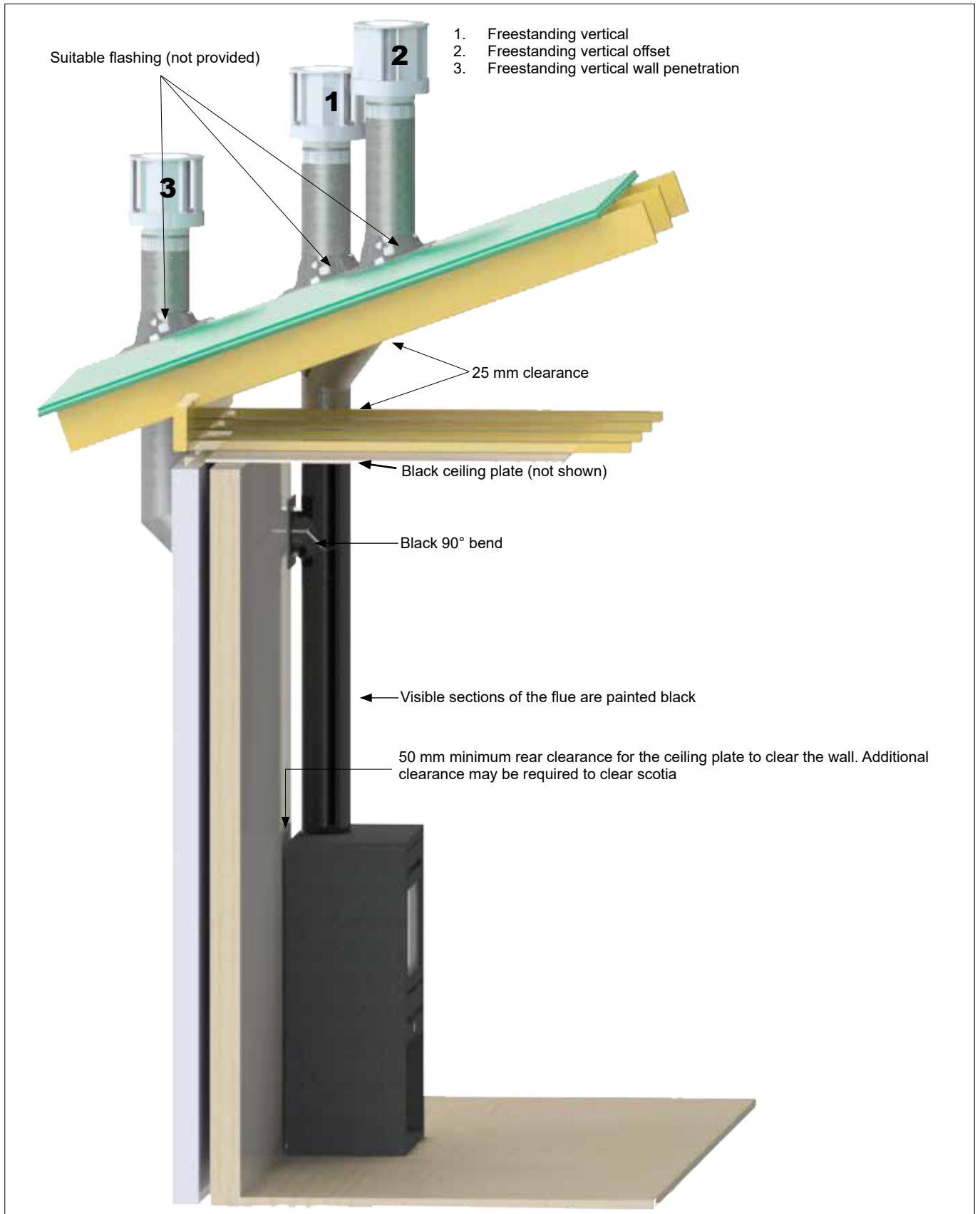

FLUE KITS AND COMPONENTS

R3706: Freestanding flue kit DV black 3.6 m

Black powder coated freestanding flue kit. Contains:

- RDV902: 1 x 1200 mm flue pipe unpainted
- RDV902B: 2 x 1200 mm flue pipe black
- RDV991: Coaxial flue cowl
- RDVCP90: Cover plate black
- RDV954: 2 x wall straps

Flue pipes cannot be cut to size. Once joined the nominal length reduces approximately 35 mm.

- Inner: Aluminium (Ø100 mm)
- Outer: Galvanised steel (Ø170 mm)

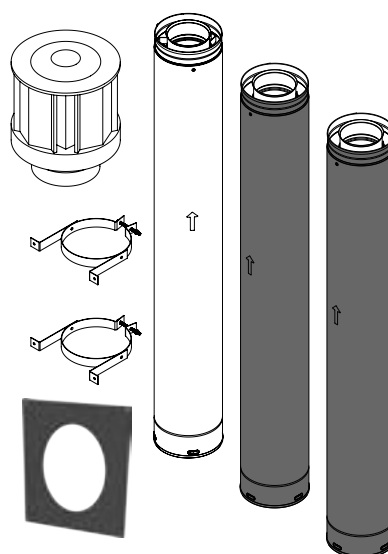

UNPAINTED DV coaxial flue pipes

Interlocking pipe used to construct vertical flueing.

CANNOT be cut to size. Once joined nominal length reduces approximately 35 mm.

- Inner: Aluminium (Ø100 mm)
- Outer: Galvanised steel (Ø170 mm)

Pipe	Installed length	Code
225 mm	191 mm	RDV907
300 mm	267 mm	RDV906
600 mm	572 mm	RDV904
900 mm	876 mm	RDV903
1200 mm	1181 mm	RDV902



PAINTED DV coaxial flue pipes

Interlocking pipe used to construct vertical flueing. **CANNOT** be cut to size. Once joined nominal length reduces approximately 35 mm.

- Inner: Aluminium (Ø100 mm)
- Outer: Galvanised steel (Ø170 mm) powder coated black

Pipe	Installed length	Code
225 mm	191 mm	RDV907B
300 mm	267 mm	RDV906B
600 mm	572 mm	RDV904B
900 mm	876 mm	RDV903B
1200 mm	1181 mm	RDV902B

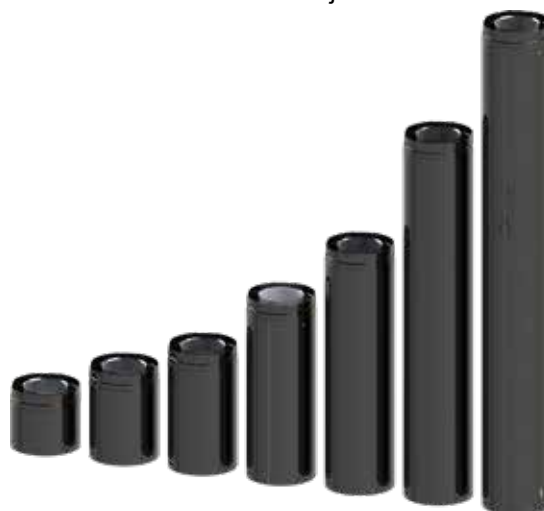

Flue Kits and Components (cont.)

Coaxial vertical flue cowl

RDV991

Aluminium flue terminal required for all coaxial vertical flue installations—part of all vertical flue kits.

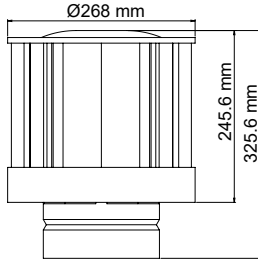

DV flue pipe extensions unpainted, and painted

75-360 mm	RDV911 (unpainted)	RDV911GL (painted)
-----------	--------------------	--------------------

Used for extended straight lengths of flue. Available in two lengths—extending to 175 mm or 360 mm. **CANNOT** be cut to size. Painted variants are powder coated black.

Inner: Aluminium Ø100 mm Outer: Galv. steel Ø170 mm

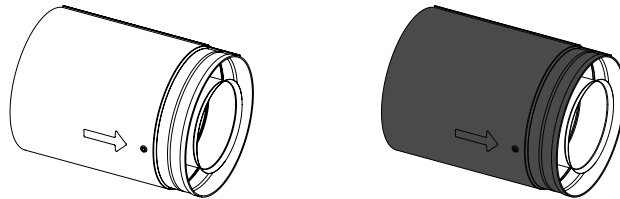

Coaxial 45° flue elbows (two bends in a kit)

RDV945G (unpainted)	RDV945B (painted, powder coated black)
---------------------	--

Offsets obstructions. Elbow swivels 360° at base. Angle not adjustable. Once joined effective length reduces 35 mm to approx. 73 mm.

Inner: Aluminium Ø100 mm Outer: Galv. steel Ø170 mm

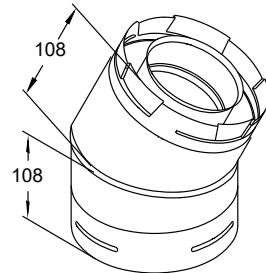

Coaxial 90° flue elbow unpainted, and painted

RDV990G (unpainted)	RDV990B (painted, powder coated black)
---------------------	--

Used to facilitate between vertical and horizontal flueing. Elbow swivels at base. Angle not adjustable. Once joined effective length reduces 35 mm to approx. 130 mm

Inner: Aluminium Ø100 mm Outer: Galv. steel Ø170 mm

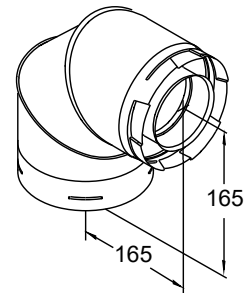

45° black plate

RDVCP45

Black 45° plate to cover/tidy hole where flue pipe penetrates, used in offset installations.

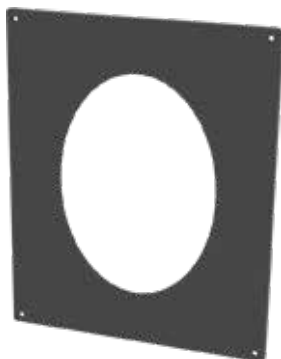

Cover plate black

RDVCP90

Galaxy black ceiling/wall plate to cover/tidy hole where flue pipe penetrates.

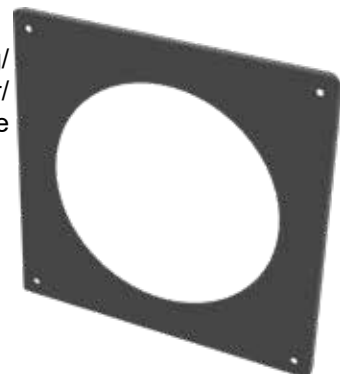

Flue Kits and Components (Cont)

Wall strap DV

RDV954

Adjustable strap used in installations to add lateral support to the flue.

Provides a 50-200 mm clearance to combustibles.

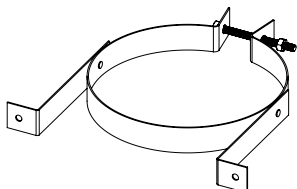

Elbow flue strap DV

RDV951

Flue supports for elbows and offsets. Strap length approximately 432 mm.

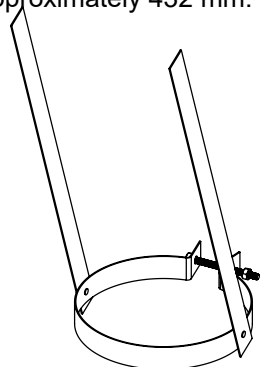

High wind vertical cowl protection kit

RDB 992

Designed to wrap around the vertical cowl (as pictured) to reduce wind entering the flue and causing disturbances. It is fitted to the cowl and can be retrofitted.

Construction - stainless steel

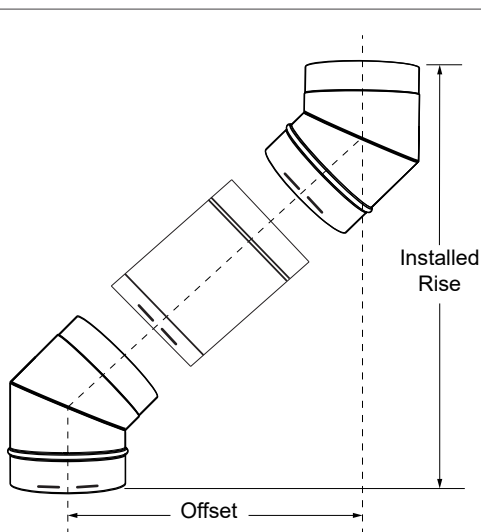
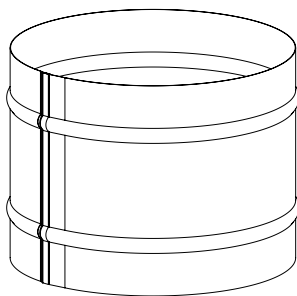

Flue pipe (length and code)		Offset	Installed Rise
None (bend to bend)	N/A	124 mm	288 mm
225 mm	RDV907	257 mm	423 mm
300 mm	RDV906	311 mm	477 mm
600 mm	RDV904	524 mm	792 mm
900 mm	RDV903	737 mm	908 mm
1200 mm	RDV902	949 mm	1123 mm

COMMISSIONING

GENERAL INFORMATION



**HAZARDOUS VOLTAGE.
Risk of Electrical Shock.**



Disconnect all sources of supply prior to servicing



Step 1. Unpack the Fascia

For commissioning, the control panel located on the fascia will need to be connected to the communication cable of the heater engine.

Remove all packaging materials and check all components for damage. If **ANY** damage is evident **DO NOT** install or operate this appliance. Contact your supplier for advice.

Step 2. Connect Push Button Control

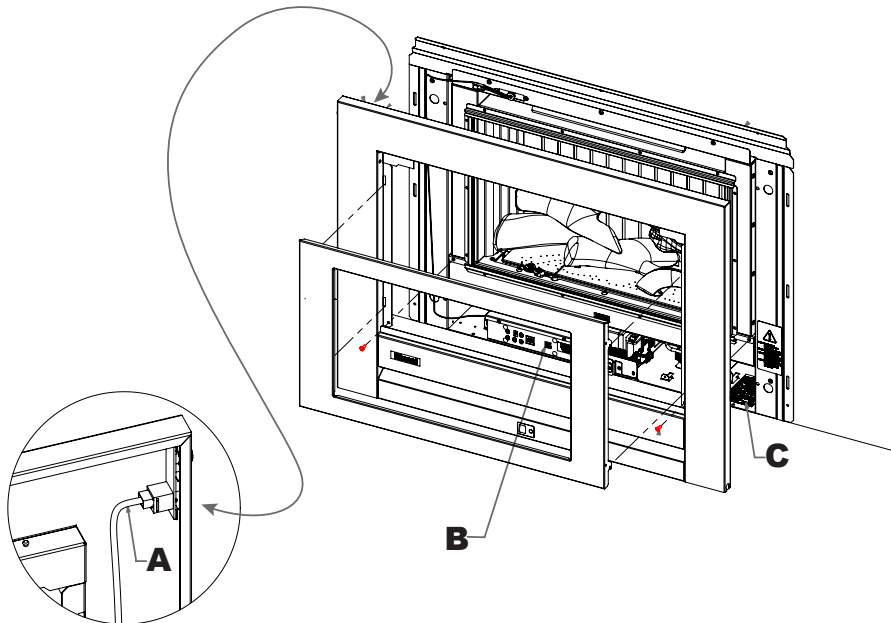

Carefully pick up fascia assembly, and position the fascia close to the heater engine.

Connect the RJ45 Cable and Plug **(A)** into the socket **(B)** located on the front of the heater (this connects the push button control panel via a communications cable to the heater engine's control box).

Step 3. Switch on the Electricity Supply



230 VOLTS, RISK OF ELECTRICAL SHOCK!

Installation and commissioning **MUST** be carried out **ONLY** by an Authorised person.

Wiring inside this appliance may be at 230V potential, when performing the commissioning, the appliance electrical power will need to be connected. Exercise **CAUTION** as there is potential for electric shock from the exposed wiring and circuitry. **DO NOT** leave the appliance unattended when power is connected and the panels are removed.

Step 4. Commission the Appliance



DO NOT test for gas leakage with an open flame.

The gas type codes and gas pressures for this appliance **MUST** be checked and set in accordance with these instructions when the appliance is installed, **OR** after the replacement of any component or reassembly after service.

Burner gas pressures and gas types are factory set.

The location of the gas control is in the air gap at the lower right hand side of the appliance.

The location of the data plate is on the base plate of the heater engine within the air gap on the right hand side of the appliance **(C)**.



Gas supply pressure is to be checked with all other gas appliances in the household running on high. Failure to check this may result in lower than recommended required gas pressures, resulting in poor performance and reduced flame effect.

Step 5. Checking Supply Pressure (Ensure gas is connected)

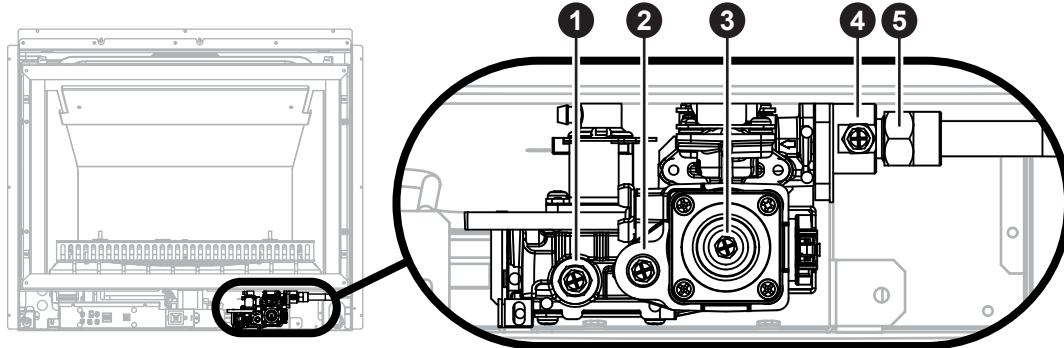

1. Remove the gas inlet test point screw ④, and connect the positive pressure manometer hose. Refer to valve drawing above.
2. Press the heater ON/OFF button ⑫, on the PCB control panel to start the ignition sequence. The appliance will ignite normally. Refer to PCB Control panel image below.

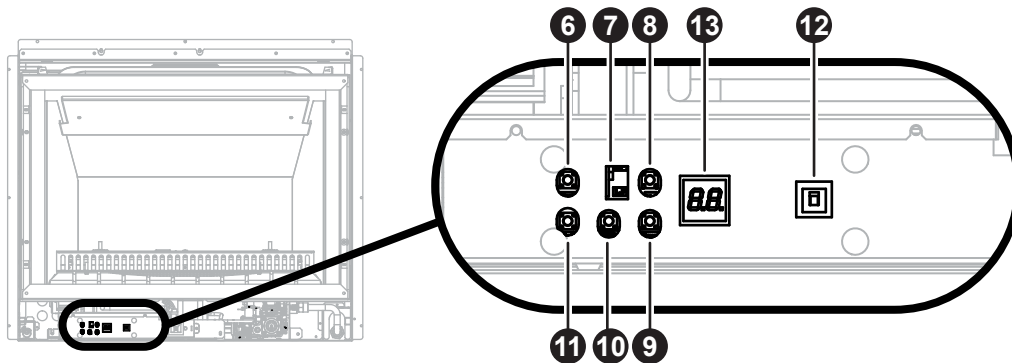

	Natural Gas	Propane Gas
Minimum Supply Pressure	1.13 kPa	2.50 kPa
Maximum Supply Pressure	3.50 kPa	3.00 kPa

Refer to chart for the correct gas settings, (data plate values override values printed in this instruction).

3. Check the pressures as per the chart below for the correct gas type. Ensure all other gas appliances in the household are running on 'High'
4. Press the heater ON/OFF button ⑫ to stop the appliance operation.
5. Disconnect the manometer hose and replace the inlet test point screw ④. Check for leaks using soapy water solution.

Step 6. Checking and Setting burner gas pressure

1. Remove the main burner test point screw ❶, and connect the positive pressure manometer hose.
2. Press the heater ON/OFF button ❷, on the PCB control panel to start the ignition sequence. The appliance will ignite normally. Refer to PCB Control panel image above.
3. Press the 'TEST' button ❸, twice on the PCB control panel, the igniter will spark and the appliance will light to its lowest setting, (Main burner - stage 1), and the display ❹, will show P_L (stage 1).
4. Press the 'UP' button ❺ or 'DOWN' button ❻ to adjust to the required value if values are different to those in the table below.

Model	Natural Gas		Propane Gas	
	SS850		SS850	
P_L (stage 1)	0.20 kPa	0.20 kPa	0.50 kPa	0.50 kPa
P_H (stage 7)	0.90 kPa	0.86 kPa	1.95 kPa	1.92 kPa

Refer to chart for the correct gas settings, (data plate values override values printed in this instruction).

5. Press the 'SET' button ❿, once to save the setting. The display ❹, should now be displaying P_H , (Main burner stage 7).
6. Press the 'UP' button ❺ or 'DOWN' button ❻ button to adjust to the required value, If the pressure is already correct or when the desired pressure is achieved press the 'SET' button ❿, once to save the setting.
7. The display ❹, will now show $\bar{7}$. If the display does not change to there was an error in pressure setting and the pressure setting procedure should be repeated from step 1 onward after turning the appliance 'OFF'
8. With the display ❹, showing $\bar{7}$. Press the heater ON/OFF button ❷.
9. Setting main burner pressure is now complete. Remove the manometer hose and replace the inlet test point screw ❶. Check for leaks using soapy water solution.

Step 7. Checking and setting Pilot burner pressure

1. Remove the pilot burner gas test point screw ❷, and connect a positive pressure manometer hose.
2. Press the heater ON/OFF button ❷ to start the ignition sequence, the appliance will ignite normally.
3. Press the 'TEST' button ❸, twice on the PCB control panel, the igniter will spark and the appliance will light to its lowest setting, (Main burner - stage 1), and the display ❹, will show P_L .
4. Adjust the pilot burner gas pressure to the value for the gas type as listed in the table below via the 'Pilot Burner Pressure Adjustment' screw ❸.

	Natural Gas	Propane Gas
Pilot Burner Pressure	1.00 kPa	2.00 kPa

Refer to chart for the correct gas settings, (data plate values override values printed in this instruction).

5. Press the heater ON/OFF button ❷, once to stop the appliance operation. Disconnect the manometer hose and replace the pilot burner gas test point screw ❷.
6. Check for gas leaks using soapy water, setting or checking pilot burner pressure is now complete.



The requirements of AS / NZS 5601 include:

- a. checking whether mechanical extraction ventilation draws air through flue systems or chimneys or not. If yes, this will most likely result in combustion product spillage from appliances during their operation.
- b. checking whether the operation of appliances and flue systems or chimneys is satisfactory.
- c. a method for determining the additional fixed ventilation area required to counteract the effect of mechanical extract ventilation.



Always check gas pressure values with those recorded on this appliance's data plate. Values on the data plate override values printed in this instruction.

COMMISSIONING THE APPLIANCE FOR DIFFERENT GAS TYPE



230 VOLTS, RISK OF ELECTRICAL SHOCK!

Installation and commissioning **MUST** be carried out **ONLY** by an Authorised person.

Wiring inside this appliance may be at 230V potential, when performing the commissioning, the appliance electrical power will need to be connected. Exercise **CAUTION** as there is potential for electric shock from the exposed wiring and circuitry. **DO NOT** leave the appliance unattended when power is connected and the panels are removed.

This appliance is factory set for the correct gas type as per its gas type labelling. Re-commissioning for gas type will only be required if the PCB is being replaced or if it has undergone a gas type conversion, i.e.; from NG to Propane or vice versa. Commissioning of the gas is carried out via the PCB.



Commissioning of the PCB **MUST** be carried out **BEFORE** the gas pressures are checked.

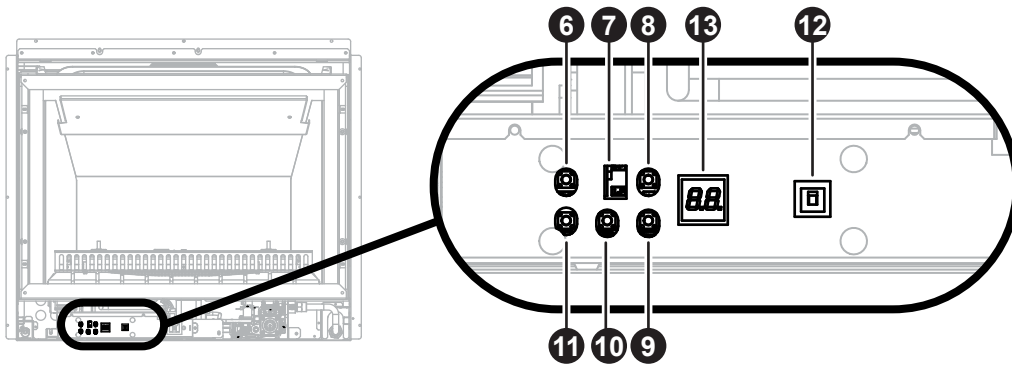

1. Turn on the gas and power supply to the appliance.
2. Press the 'UP' button or 'DOWN' button to obtain the correct gas type code for the appliance. Refer to chart to below for the correct gas type code.

Natural Gas	Propane Gas
A1	L1

3. With the appliance OFF, press the 'TEST' button, the gas type code will be shown on the display.
4. Press the 'SET' button, to lock in the code.
5. Gas pressure settings should now be checked as per "Step 7. Checking and setting Pilot burner pressure" on page 32, point 1 through 3.

ATTACHING FASCIA ASSEMBLY

Attach the Fascia to the Heater Engine

1. Ensure the CAT5 cable **(A)** is installed into the ON/OFF button on the frame and clipped in place in the front of the fire **(B)**.
2. Fit the frame over the top flange of the fire to prevent it becoming out of place.
3. Fix the frame to the fire using the two supplied black M4 screws **(3)**.



It is **CRITICAL** to the safe operation of the fire that these screws are in place (seals the fire).

4. Fit the inner frame to the fire by setting it into the allocated slot of the outer frame and sliding it down.
5. On the PCB control panel **(B)**, return the button to the ON position. Check the operation of the ON/OFF button on the frame and that the remote control is working.

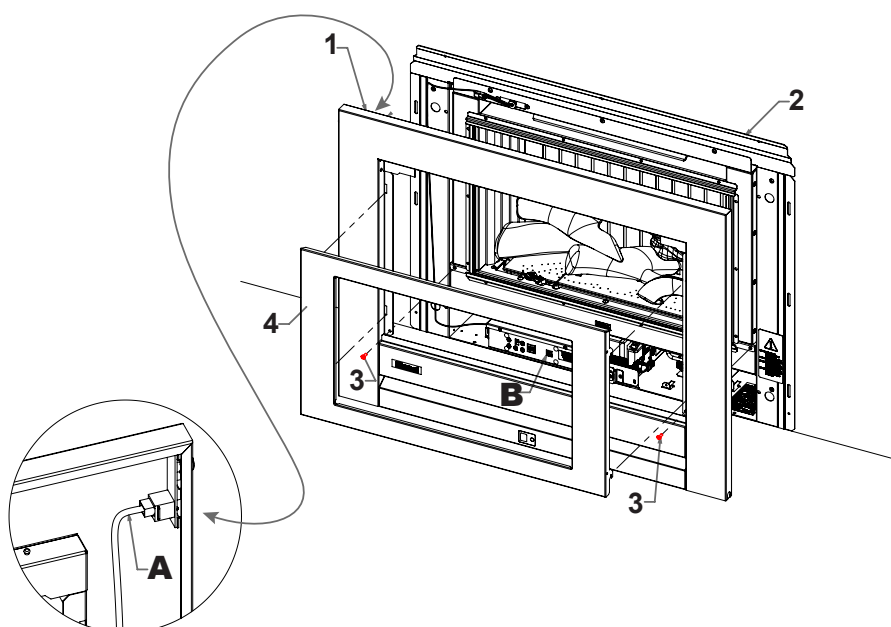

Ensure you **DO NOT** place excessive tension on or pinch the communication cable when manoeuvring the fascia into position.



The glass of the fascia fitted to this appliance reduces the risk of fire and injury and no part of it **MUST** be permanently removed.

For protection of young children or the infirm a secondary guard (not supplied) is required.

ABNORMAL FLAME PATTERN

Each Rinnai Gas Fire has a distinct flame pattern. The flame should look the same every time you start your heater, after an initial warm up period of approximately 15 minutes.

Abnormal flame performance and/or pattern can indicate a problem with your heater, such as blocked gas injectors, incorrectly installed / inadequate flue system or the Ceramic logs may have shifted from when the heater was first installed.

There are some warning signs that could indicate a problem. If any of the signs below occur, please contact Rinnai.

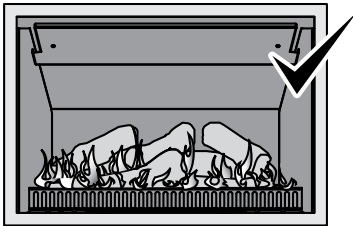

NORMAL FLAME PATTERN

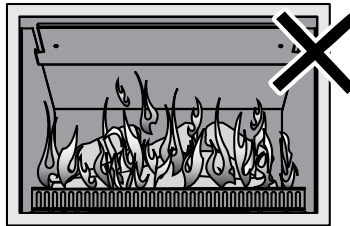

ABNORMAL FLAME PATTERN

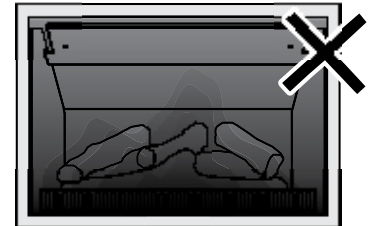

SOOT BUILD UP

Key signs of abnormal flame performance:

- Appliance turns 'OFF' soon after start up and does not relight.
- Continued difficulty or delay in establishing a flame
- Flame appears overly orange-yellow.
- Flame appears either very short or very long.
- Flame only burns part way across the burner.
- Severe soot building up on the inside of the glass or on logs.
- Continuous unusual smell from the appliance.
- Continued difficulty or delay in establishing a flame.



This appliance incorporates a live fuel effect and is designed to operate with luminous flames. This may leave slight carbon deposition as part of its normal operation.

INSTALLATION CHECKLIST



It is the responsibility of the installer to complete both the "Installation Checklist" below and the "Installation Record" on the next page and in the Operation Manual at the completion of installation.

Instruct customer on the heater operation and ensure the customer understands the content of the operation manual.



Advise the customer that during the initial burning period of approximately 2 hours, some smoke and odour may be experienced.

During this period the heater should be operated on 'High' and the space being heated should be well ventilated. It may take up to 20 minutes of operation for the logs to achieve their full flame pattern and glow.

Complete the "Installation Record" on the next page and in the Operation Manual

THE GUARD IS FITTED TO THIS APPLIANCE TO REDUCE THE RISK OF FIRE OR INJURY FROM BURNS AND NO PART OF IT SHOULD BE PERMANENTLY REMOVED.

FOR PROTECTION OF YOUNG CHILDREN OR THE INFIRM, A SECONDARY GUARD IS REQUIRED.



The guard supplied with this appliance **MUST NOT** be permanently removed as it fulfils an operational safety function. Additional dress guards including free standing types may be used in conjunction with, but **NOT** replace, the dress guard supplied with this appliance.

The appliance is not intended for use by young children or infirm persons without supervision. Young children and the infirm **SHOULD** be supervised at all times when in the vicinity of this heater while it is in operation.

Ensure the Customer understands that:

- No part of this appliance should be permanently removed.
- Young children and the infirm should be supervised at all times.
- Paper or other material **MUST NOT** be burnt in this appliance.



The following checklist is to be completed **ONLY** by a Certified Gas Installer.

	No	Yes
1. Is the appliance positioned in a suitable location (clearances, combustible clearances, mantels and surrounds etc.)?	<input type="checkbox"/>	<input type="checkbox"/>
2. Was a Rinnai approved flue system installed and tested in accordance with the instructions?	<input type="checkbox"/>	<input type="checkbox"/>
3. Has the gas pressure been checked and set with all gas appliances running?	<input type="checkbox"/>	<input type="checkbox"/>
4. Has the log set / burn media been installed as per instructions?	<input type="checkbox"/>	<input type="checkbox"/>
5. Has the appliance tested for correct operation and to ensure no gas leaks?	<input type="checkbox"/>	<input type="checkbox"/>
6. Has combustion product spillage testing been conducted in accordance with AS/NZS5601?	<input type="checkbox"/>	<input type="checkbox"/>
7. Has the customer been instructed on operating procedure and safety requirements?	<input type="checkbox"/>	<input type="checkbox"/>
8. Is the end-user fully aware of operating procedure and has the manuals?	<input type="checkbox"/>	<input type="checkbox"/>
9. Has the Glass or Mesh Dress Guard been fitted?	<input type="checkbox"/>	<input type="checkbox"/>
10. Has the customer been advised not to remove the Dress Guard?	<input type="checkbox"/>	<input type="checkbox"/>
11. Has the customer been advised to service the heater every two years?	<input type="checkbox"/>	<input type="checkbox"/>

INSTALLATION RECORD



This appliance **MUST** be installed, maintained and removed **ONLY** by an Authorised Person.
For continued safety of this appliance it **MUST** be installed and maintained in accordance with the manufacturer's instructions.

The Installation Record is a reference for the end user, help line staff and service technicians. Ensuring that this information is available here will be helpful in the event that a service enquiry is required.

Installation Details

Installation Company Name: _____

Address: _____

Telephone / Mobile Phone: _____ / _____

Email: _____

Certificate of Compliance / Certification No.: _____

Authorised Persons - Licence No.: _____

Installers Name: _____

Installers Signature: _____

Installation Date: _____

Model Number *

Serial Number *

Installation Address: _____

** This information will need to be copied from the data plate, located on the inside of the appliance.*



Ensure this Installation Record is kept for future reference.



Ensure installer has instructed you on the correct use of this appliance and completes the "Installation Checklist" found on page 36 of the Installation Manual.

SPECIFICATIONS

APPLIANCE DETAILS

Model	Rinnai SS850 Freestanding
Features	Room-Sealed Freestanding Gas Space Heater Burning Log and Stone Fire Bed Effect Glass front Convection Fan, top warm air outlet Glass dress guard Infra Red (IR) remote control
Data Plate	Located on the lower RHS of the base panel in front of the gas control.
Input	14~30 MJ/h
Output (High)	6.6 kW*
Efficiency	80%
Heating area	65-112m ² **
<i>Note: * will vary accordingly to gas type and flue configuration. ** will vary depending to geographical location.</i>	
Installation Types	Suitable for freestanding installations in open plan areas and living rooms. As a room-sealed appliance it can also be installed in larger bedrooms if this meets the 6.10.6.1 requirements of AS/NZS 5601.1.
Combustion Method	Bunsen type burner
Flueing	Coaxial direct vent flueing (inner Ø100mm, outer Ø170mm). Appliance must be installed with a Rinnai flue System.
Convection Fan	120V AC 50 Hz-2-speed centrifugal blower
Gas Connection	Brass 1/2" BSPT male fitting, the gas supply terminates inside the heater - lower right hand side of the appliance.
Gas Type	NG, Propane
Electrical	This heater has a 1.5 m power cord with a three pin plug supplied, the power cord passes through a slot in the back left hand corner of the appliance.
Ignition	230-240 V AC 50 Hz high voltage electronic spark ignition
Power Consumption	When on High, 50W When on Standby, less than 3W
Safety Devices	Overheat Switch Pressure relief on glass panel - burner box Thermal Fuse, over-current fuse Flame Failure Sensing System Refer to "SAFETY DEVICES" on page 7 of the Operation Manual for information regarding additional safety devices and features.
Glass - Primary Glass - Secondary Glass seal material	Ceramic Glass Tempered Glass Woven fibreglass chord
Weights	SS850 Freestanding Cube = 75kg. Freestanding Cabinet Base = 14kg. Freestanding Plinth Base = 10kg.
Operation	Push button control panel, Infra Red Remote Control.
Noise Level	37~45 dB(A)



Refer to appliance data plate for Gas Type, Gas Rates, Injector Sizes and Burner Pressures.

DIMENSIONS

Freestanding

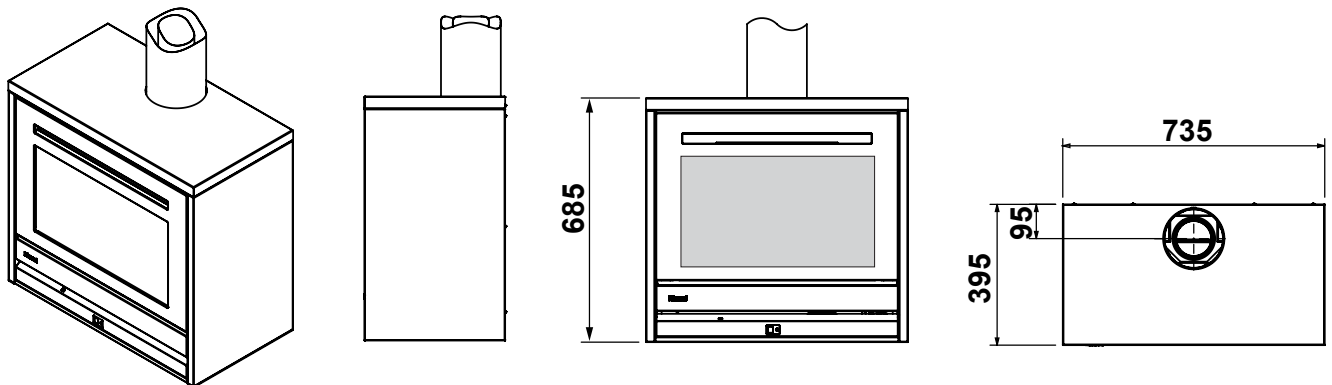

Freestanding - with Cabinet Base

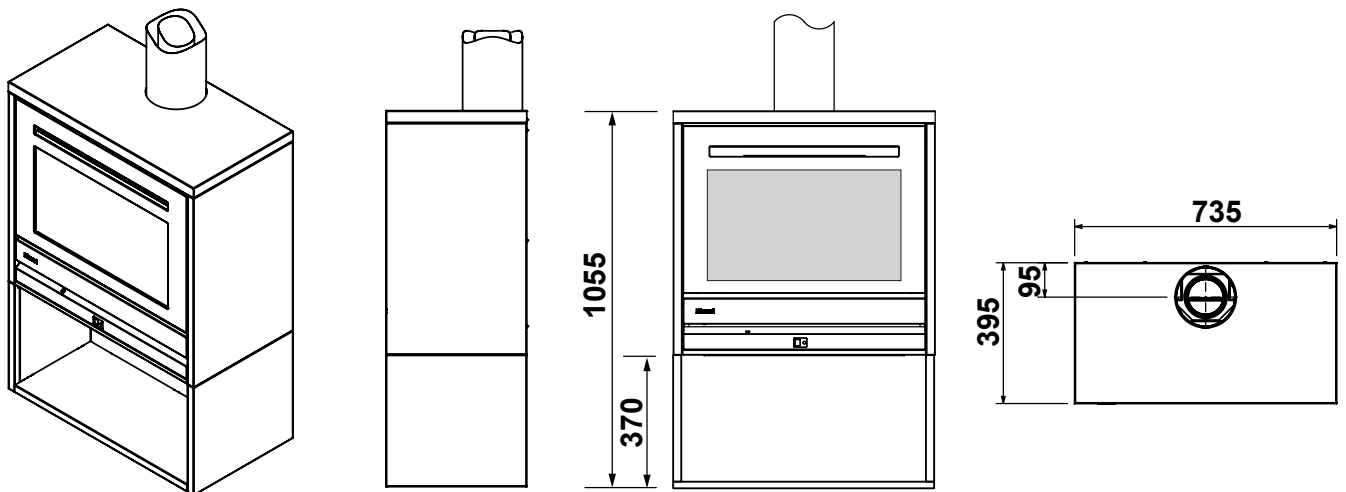

Freestanding - with Plinth Base

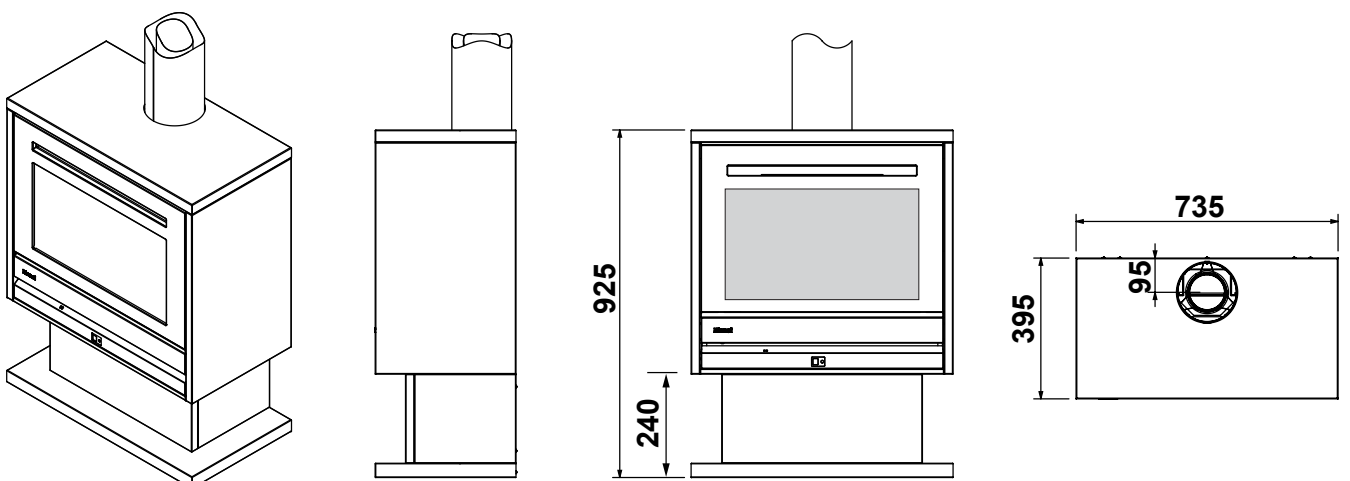

SPECIFICATIONS

WIRING DIAGRAM

Mark	Part
B	Burner
ER	Electrode
F	Fuse Electrical
FM	Convection Fan Motor
FR1-2	Flame Rod 1-2
L	Light
OH.TH1	Over Heat Thermistor
PB	Pilot Burner
POV	Modulated Solenoid Valve
R.TH	Room Thermistor
RCR	Remote Control Circuit
SP	Sparker
SV1-3	Main Solenoid Valve 1-3
TF	Thermal Fuse
TR	Transformer

Mark	Colour
bk	black
bl	blue
gr/y	yellow-Green stripe
gy	grey
or	orange
pl	purple
r	red
w	white
y	yellow
p	pink
br	brown

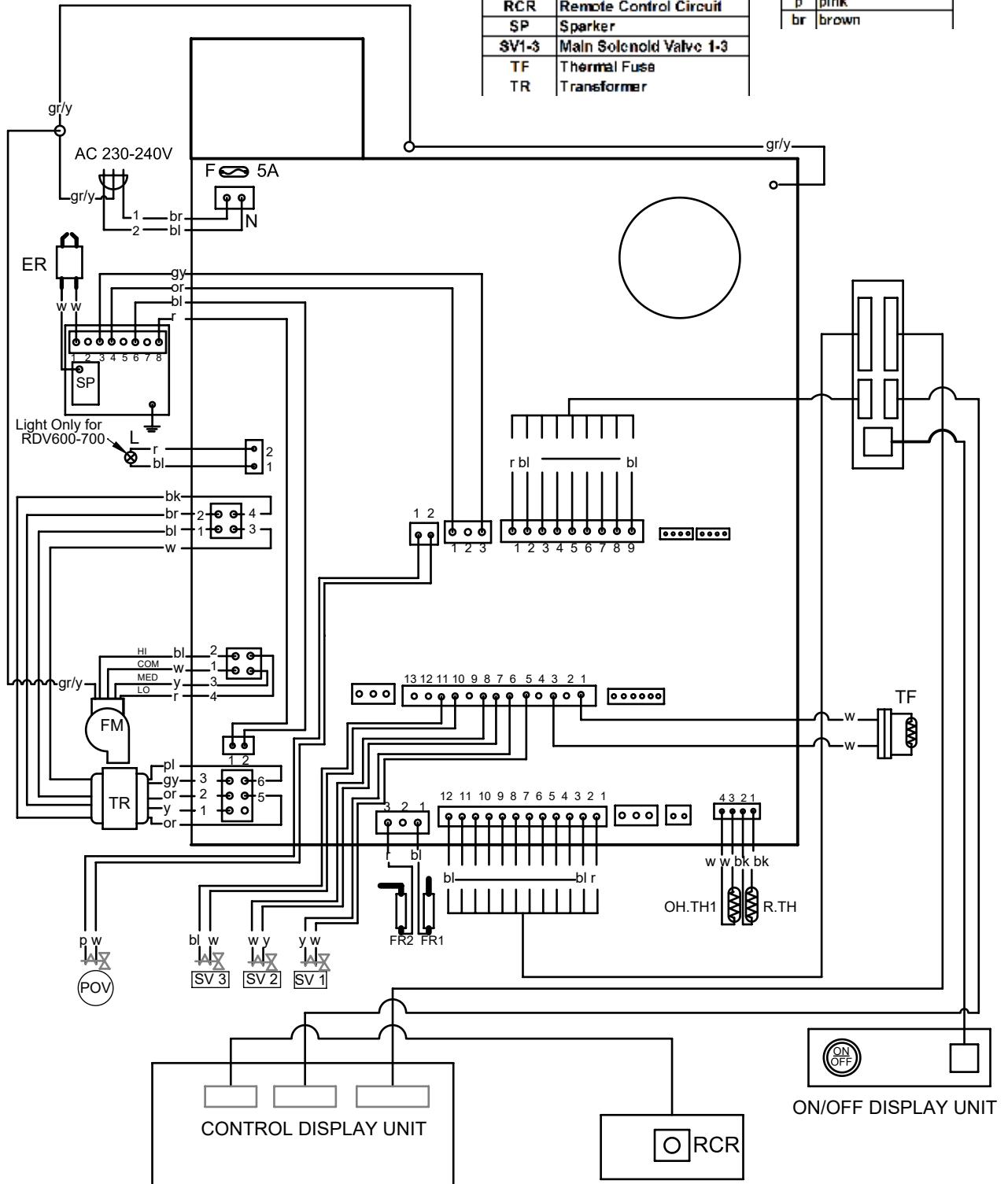

WIRING DIAGRAM UNI CONTROL
RIB23, RDV23
Issue A



Rinnai Australia Pty Ltd

ABN 74 005 138 769 | AU45204

100 Atlantic Drive, Keysborough, Victoria 3173
P.O. Box 460, Braeside, Victoria 3195
Tel: (03) 9271 6625
Fax: (03) 9271 6622

National Help Line

Tel: 1300 555 545* Fax: 1300 555 655
Monday to Friday, 8.00 am to 5.00 pm EST.

**Cost of a local call may be higher from mobile phones.*

For further information visit **www.rinnai.com.au**
or email **enquiry@rinnai.com.au**

Rinnai has a Service and Spare Parts network with personnel who are fully trained and equipped to give the best service on your Rinnai appliance. If your appliance requires service, please call our National Help Line. Rinnai recommends that this appliance is serviced every 2 years.

With our policy of continuous improvement, we reserve the right to change, or discontinue at any time, specifications or designs without notice.