

MODELS

CHP020

CHP040

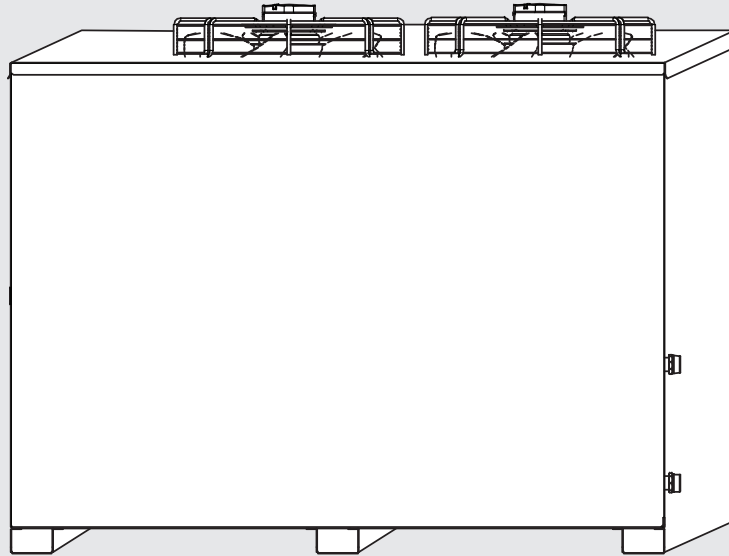

# Commercial Air to Water Heat Pump

## Operation & Installation Manual

**Rinnai**

Congratulations on the purchase of your Rinnai appliance. We trust you will have many years of comfort and enjoyment from your appliance.



#### BEFORE USING THIS APPLIANCE

**Before proceeding with the operation or installation read this manual thoroughly and gain a full understanding of the appliance, to ensure safe and correct use.**

#### IMPORTANT NOTICE FOR INSTALLERS

**Please leave these instructions with the end user after commissioning of the system and alert the end user of the content sections "Warnings and "Periodic Inspection" and "Maintenance".**

This appliance must be installed in accordance with:

- Manufacturer's Installation Instructions
- Current AS/NZS 3500
- Plumbing Code of Australia (PCA)
- Local Regulations and Municipal Building Codes including local OH&S requirements

This system must be installed, commissioned, serviced, maintained and removed **ONLY** by an Authorised Person.

#### **NOT SUITABLE AS A POOL OR SPA HEATER**

For continued safety of this appliance it must be installed and maintained in accordance with the manufacturer's instructions.

Certified  
Product



WaterMark  
AS3498 Lic W00169  
SAI Global

# TABLE OF CONTENTS

Warnings and Important Information	5
<b>Safety and Regulatory Information</b>	<b>5</b>
<b>Transport and Storage of Appliance</b>	<b>6</b>
<b>Lifting</b>	<b>6</b>
<b>Scald Hazards</b>	<b>7</b>
<b>Operation Principle</b>	<b>8</b>
<b>Safety Devices</b>	<b>9</b>
Pressure & Temperature Relief (PTR) Valve	9
<b>Excessive Discharge from Safety Devices</b>	<b>9</b>
Pressure & Temperature Relief (PTR) Valve	9
Expansion Control Valve (ECV) - if required	9
<b>Hydrogen Gas</b>	<b>10</b>
<b>Turning Off the Water Heating System</b>	<b>10</b>
<b>Turning On the Water Heating System</b>	<b>10</b>
<b>Draining</b>	<b>10</b>
<b>Maintenance and Regular Care</b>	<b>10</b>
Save a Service Call	11
<b>Specifications</b>	<b>13</b>
<b>System Specifications</b>	<b>13</b>
<b>Dimensions</b>	<b>14</b>
<b>Clearances</b>	<b>15</b>
<b>Unit Main Components Overview</b>	<b>16</b>
<b>Main Electric Components In Switchboard</b>	<b>17</b>
Installation	18
<b>Regulations and Occupation Health and Safety (OH&amp;S)</b>	<b>18</b>
<b>Location</b>	<b>18</b>
Internal Installation	18
Condensation	18
Drainage	18
<b>Water Supply</b>	<b>19</b>
<b>Storage Temperature</b>	<b>19</b>
<b>Hot Water Delivery Temperature</b>	<b>19</b>
<b>Valves and Fittings</b>	<b>19</b>
<b>Positioning The Heat Pump</b>	<b>20</b>
<b>Installation Dimensions</b>	<b>20</b>
<b>Connect the PTR Valve</b>	<b>21</b>
<b>Plumbing Connections</b>	<b>21</b>
<b>Equal Flow Principle</b>	<b>22</b>
<b>Typical Installations</b>	<b>23</b>
<b>Connect Cold / Hot Water Supply</b>	<b>24</b>
<b>Electrical Tests</b>	<b>24</b>
Conducting Insulation (Megger) Tests	24

<b>Electrical Connections .....</b>	<b>24</b>
Main Power .....	24
Primary Pump .....	25
Tank Sensor Installation .....	25
Auxiliary Booster (optional) .....	25
<b>Filling the System and Commissioning .....</b>	<b>25</b>
<b>Finishing the Installation .....</b>	<b>26</b>
<b>User Terminal .....</b>	<b>27</b>
Keypad .....	27
Icons .....	27
Operation .....	28
<b>Applica App .....</b>	<b>28</b>
<b>Alarm Codes &amp; Troubleshooting .....</b>	<b>31</b>
<b>Commissioning Log &amp; Checklist .....</b>	<b>32</b>
<b>BMS Setting .....</b>	<b>33</b>
<b>Menu steps .....</b>	<b>34</b>
<b>Registry Information .....</b>	<b>35</b>
<b>Contact .....</b>	<b>36</b>

# WARNINGS AND IMPORTANT INFORMATION

## SAFETY AND REGULATORY INFORMATION



**DO NOT operate this system before reading the manufacturers instructions.**

**This appliance must be installed, commissioned and serviced by an authorised person in accordance with all applicable local rules and regulations.**

**Access covers of water heating system components will expose 415V wiring and MUST only be removed by an authorised person.**

**This appliance is not intended for use by persons (including children) with reduced physical, sensory or mental capabilities, or lack of experience and knowledge, unless they have been given supervision or instruction concerning use of the appliance by a person responsible for their safety.**

**For continued safety of this appliance it must be installed, operated and maintained in accordance with the manufacturer's instructions.**

**Children should be supervised to ensure they DO NOT play with the appliance.**

**The power mains must have a circuit breaker and it must be adequate for unit FLA. If the power supply cord is damaged, it MUST BE replaced by an authorised person in order to avoid a hazard. Take care not to touch the power connections or plugs with wet hands.**

**Care should be taken not to touch the pipe work as it may be HOT!**

**DO NOT place articles on or against this appliance.**

**DO NOT store chemicals or flammable materials near this appliance.**

**DO NOT operate with collectors or covers removed from this appliance.**

**DO NOT activate heat pump unless cylinder is full of water.**

**NEVER use a flammable spray such as hair spray, paint, etc near this unit as this may cause a fire.**

**At the end of the service life of the heat pump water heater and prior to being disposed of, a person qualified with refrigerant handling must recover the refrigerant from the system. The refrigerant must not be vented to atmosphere. Please call our National Help Line to arrange for an inspection.**



### MANDATORY INSPECTION PRIOR TO INSTALLATION

**Immediately report any damage or discrepancies to the Supplier of the appliance. This appliance was inspected and tested at the time of manufacture and packaging, and released for transportation without known damage. Upon receipt, inspect the exterior for evidence of rough handling in shipment. Ensure that the appliance is labelled correctly for the gas and electrical supply, and/or other services it is intended to be connected to.**

**For safety and warranty purposes, appliances that may be damaged or incorrect MUST NOT be installed or operated under any circumstances. Installation of damaged or incorrect appliances may contravene local government regulations. Rinnai disclaims any liability or responsibility whatsoever in relation to the installation or operation of damaged or incorrect appliances.**

### NOTICE TO VICTORIAN CONSUMERS

This appliance must be installed by a person licensed with the Victorian Building Authority.

Only a licensed person will have insurance protecting their workmanship.

So make sure you use a licensed person to install this appliance and ask for your Compliance Certificate.

For further information contact the Victorian Building Authority on 1300 815 127

TRANSPORT AND STORAGE OF APPLIANCE

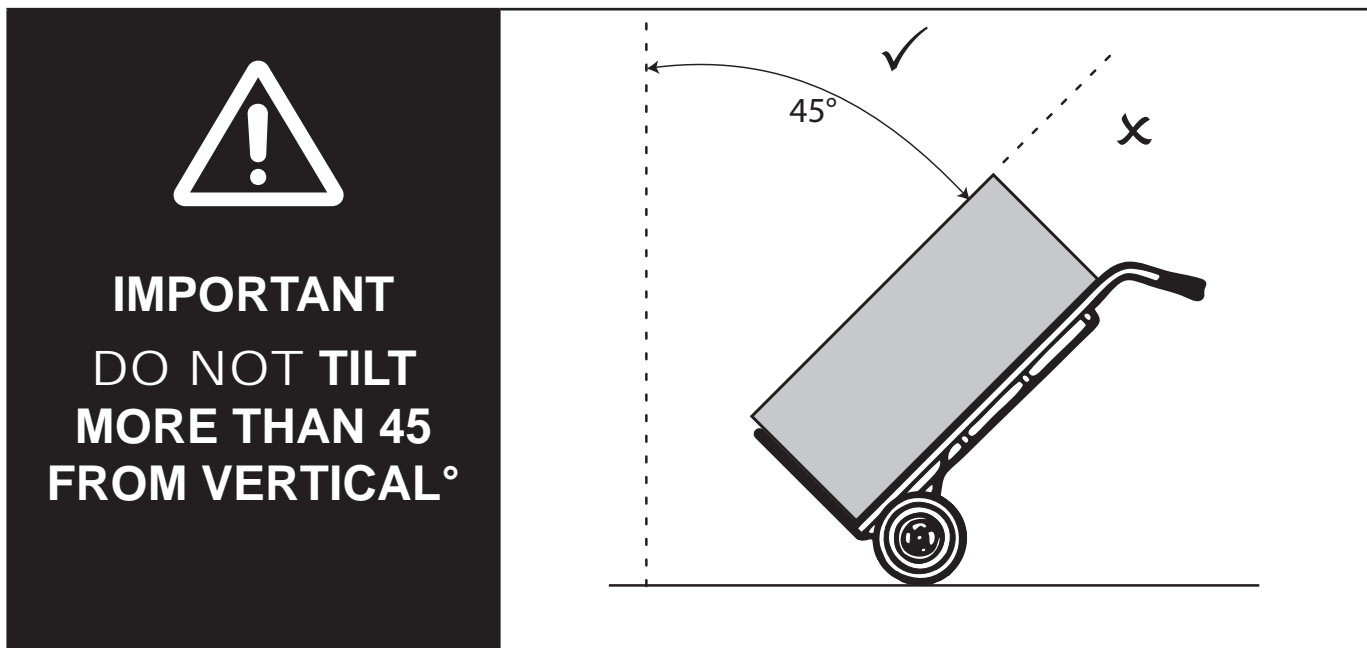

The Rinnai Electric Heat Pump must be transported at an angle no greater than 45° from vertical. Should the heat pump be tilted at a greater angle than 45° from vertical, the lubrication oil within the compressor can run down into the accumulator. This will leave the compressor motor without sufficient lubrication and lead to premature failure of the compressor unit.

As a general good practice it is better to keep the compressor upright as much as possible to avoid any risks. Returning the Rinnai Electric Heat Pump to a vertical position will not allow the oil to properly flow back into the compressor motor.

Tilting Rinnai Electric Hot Water beyond 45° from vertical will also place undue strain on compressor motor mounts and associated piping.

LIFTING

Unit weights and dimensions are detailed in the section “System Specifications” on page 13.

Please use an appropriate tonnage forklift or crane to lift the unit to its installation position. During lifting, the unit shall be kept upright and not dropped to avoid unit damage or human injuries. Slings may be inserted to the lifting points however, spreader bars **MUST** be used over unit to prevent sling or chain damage. Lifting holes are provided on foot corners of the unit as illustrated below .

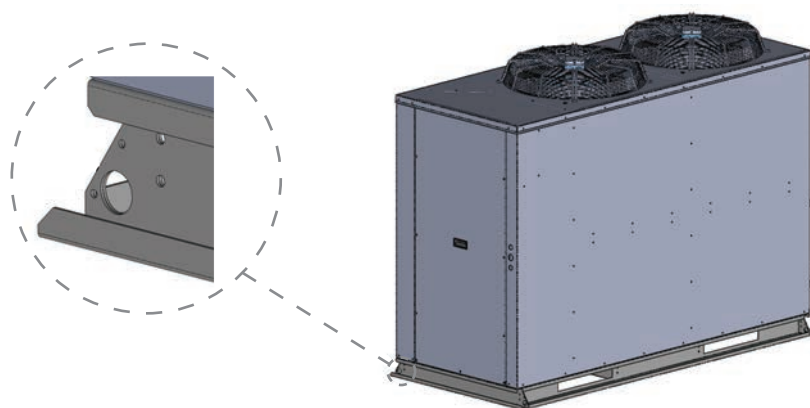

## SCALD HAZARDS



HOT WATER CAN CAUSE SCALDS.

CHILDREN, DISABLED, ELDERLY AND THE INFIRM ARE AT THE HIGHEST RISK OF BEING SCALDED.

FEEL WATER TEMPERATURE BEFORE BATHING OR SHOWERING.

SCALDS FROM HOT WATER TAPS CAN RESULT IN SEVERE INJURIES TO YOUNG CHILDREN.

SCALDS OCCUR WHEN CHILDREN ARE EXPOSED DIRECTLY TO HOT WATER WHEN THEY ARE PLACED INTO A BATH WHICH IS TOO HOT.

ALWAYS.....

**Test the temperature of the water with your elbow before placing your child in the bath, also carefully feel water before bathing or showering yourself.**

**Supervise children whenever they are in the bathroom.**

**Make sure that the hot water tap is turned off tightly.**

CONSIDER.....

**Installing child proof tap covers or child resistant taps (both approaches will prevent a small hand being able to turn on the tap).**

**Installing tempering valves or thermostatic mixing valves which reduce the hot water temperature delivered to the taps. Your local plumbing authority may already require that these be fitted. Contact your installer or local plumbing authority if in doubt.**

NEVER....

**Leave a toddler in the care of another child. They may not understand the need to have the water temperature set at a safe level.**

OPERATION PRINCIPLE

The operation of an electric heat pump is similar to a refrigerator, but in reverse. A heat pump operates by transferring heat from the ambient outside air into the water. Electricity is just used to operate the system, but not to directly heat the water. Because of this energy consumption is significantly reduced as compared to an electric element hot water system.

The warmer the climate in which the heat pump is installed, the more efficient the heat pump system will be at heating water.

The heat pump unit utilizes a circulation pump to draw water from the bottom of the storage tank and returns it to the tank at a higher temperature. A temperature sensor in the tank is used to control the heat pump operation to achieve suitable tank temperatures.

During the occasional times when the ambient weather conditions aren't suitable for the heat pump to operate, the heat pump will activate auxiliary booster (if installed) to ensure a supply of hot water.

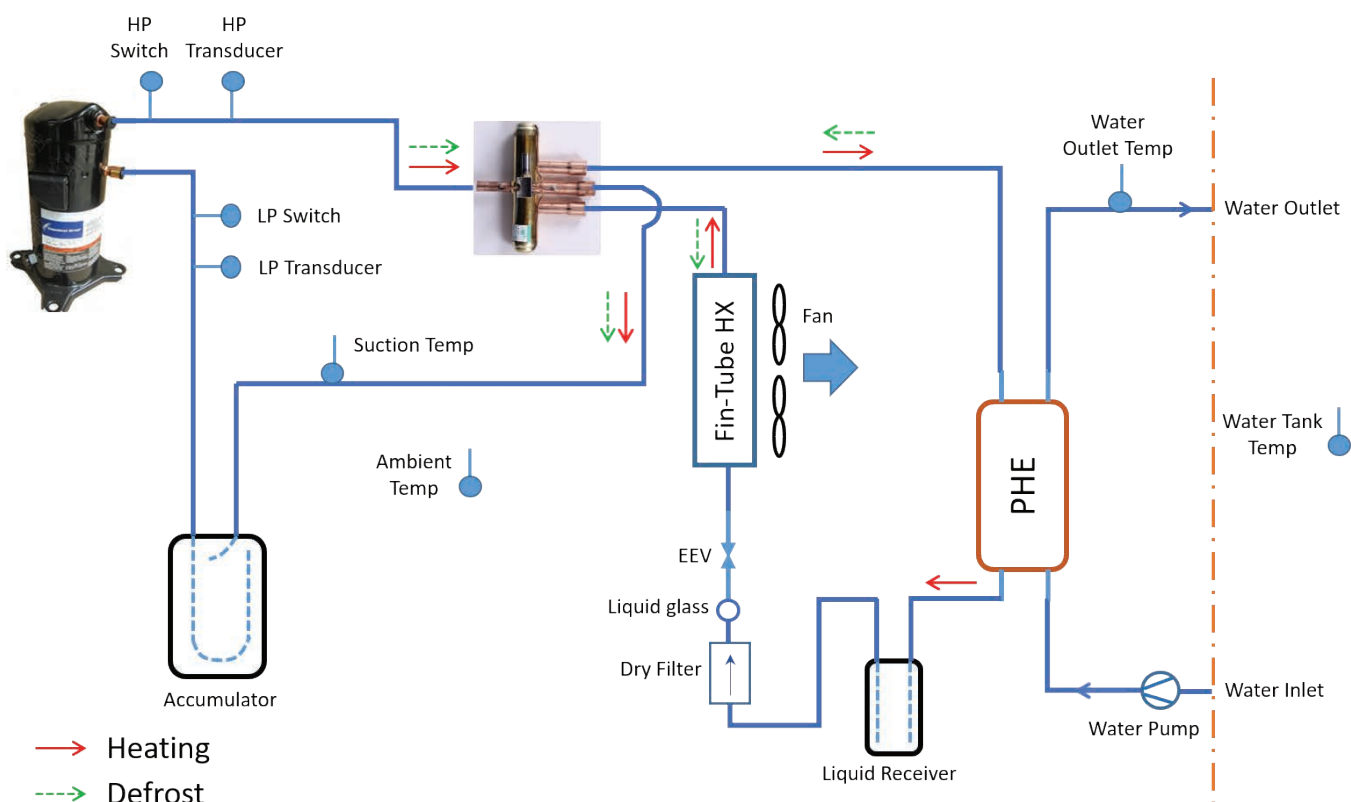

To meet the requirements of the National Plumbing Standard the temperature of the stored water has been set to 65°C.

This water heater can deliver water at temperatures which can cause scalding. Check the water temperature before use, such as when entering a shower or filling a bath or basin, to ensure it is suitable for the application and will not cause scald injury.

We recommend and it may also be required by regulations that an approved temperature limiting device be fitted into the hot water pipework to the bathroom and ensuite when this water heater is installed. This will reduce the risk of scald injury and still allow hotter water to the kitchen and laundry.



SAFETY DEVICES

The water heating system is supplied with various safety devices including temperature sensors, overheat sensors and switches and a Pressure & Temperature Relief (PTR) valve. These devices must not be tampered with or removed. The water heating system must not be operated unless each of these devices is fitted and is in working order.



- DO NOT **tamper with or remove safety devices.**
- DO NOT **operate the water heater unless all safety devices are fitted and in working order.**
- DO NOT **block or seal the PTR Valve and drain pipe.**

Pressure & Temperature Relief (PTR) Valve

This valve is located near the top of the water heater and is essential for safe operation. It is normal for the valve to release a small quantity of water through the drain line during heating.

However, continuous leakage of water from the valve and its drain line may indicate a problem with the water heater.

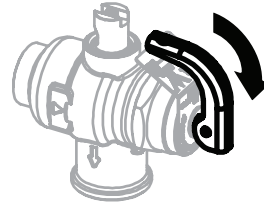

Lift lever until water flows from drain line (Lower lever gently!)



**NEVER block the outlet of the PTR valve or its drain line for any reason. The easing gear MUST be operated at least every 6 months to remove lime deposits and verify that it is not blocked. Failure to do this may result in the water heater failing.**

**If the valve does not discharge water when the easing gear lever is opened, or does not seal again when the easing gear is closed, attendance by an authorised person MUST be arranged without delay. The PTR valve is not serviceable.**

EXCESSIVE DISCHARGE FROM SAFETY DEVICES

Pressure & Temperature Relief (PTR) Valve

It is normal and desirable that this valve allows a small quantity of water to be discharged during the heating cycle. If it discharges more than a bucket of water during a 24 hour period or discharges continuously there may be another problem.

If the valve dribbles continuously, try easing the valve gear for a few seconds as described above. This may dislodge any foreign matter and alleviate the problem.

If the valve discharges at high flows, especially at night, it may be as a result of the water pressure exceeding the design pressure of the water heater. Ask your installer to fit a Pressure Limiting Valve (PLV).



**NEVER replace the PTR valve with one which has a higher pressure rating than is specified for your water heater.**

Expansion Control Valve (ECV) - if required

It is normal that this valve allows a small quantity of water to be discharged during the heating cycle. If it discharges more than a bucket of water during a 24 hour period or discharges continuously there may be another problem.

If the valve leaks continuously, try easing the valve gear for a few seconds. This may dislodge any foreign matter and alleviate the problem. If this does not alleviate the problem contact Rinnai.

Operate the easing gear regularly to remove any lime deposits and to verify that it is not blocked.

## HYDROGEN GAS

If the hot water unit is not used for two weeks or more, a quantity of hydrogen gas, which is highly flammable, may accumulate in the water heater. To dissipate this safely, it is recommended that a non electrically operated hot tap be turned on for two minutes at a sink, basin, or bath, but not a dishwasher or other appliance. During this procedure there must be no smoking, open flame or any electrical appliance operating nearby. If hydrogen is discharged through the tap, it will probably make a sound like air escaping.

## TURNING OFF THE WATER HEATING SYSTEM

If you plan to be away for only a few nights, we suggest you leave the water heating system switched on. If it is necessary to switch off the water heater, do so as outlined below:



DO NOT turn power off to the heat pump unit if snow or frost conditions are expected as components in the system may be damaged by freezing. If power needs to be turned off or power failure occurs and freezing conditions are expected, the water needs to be drained from the heat pump unit. Follow the procedure described below in the section the section 'Draining' on page 10.

## TURNING ON THE WATER HEATING SYSTEM

Switch on the electric supply to the heat pump unit. Water heating will now occur as required. It may take a number of hours before hot water is available.

## DRAINING

Draining or filling of the complete system normally only occurs during installation or servicing and must be carried out by an authorised person.

Draining water from the heat pump unit is necessary if the power will be shut off to the unit and snow or frost conditions are expected. **Arrange for an authorised person to carry out this task.**

To drain the heat pump:

1. Turn off power to the heat pump.
2. Close the cold water mains supply stop cock.
3. Close all hot water taps.
4. Operate the relief valve release lever on one of the storage tanks to release the pressure in the water heater.
5. Close the isolation valves at the inlet and outlet of the water heater and place a bucket under the cold water inlet.
6. Undo the unions at the inlet and outlet of the water heater. The heat pump holds 8 to 15 litres of water and will drain into the bucket.

## MAINTENANCE AND REGULAR CARE

Operate the easing gear of the PTR and the ECV if fitted as described in the section 'Safety Devices' on page 9. The overflow tray (supplied by installer) and drain underneath the storage cylinder (if fitted) should be periodically checked to ensure there are no blockages.

## SAVE A SERVICE CALL

Rinnai's servicing network personnel are fully trained and equipped to give the best service on your Rinnai appliance. If your appliance needs service, ring one of the service contact numbers on the back of this booklet.

The pressure and temperature relief valve and expansion control valve (if fitted) must be replaced by an authorised person at intervals not exceeding 5 years or more frequently in areas where the water is classified as scaling water.

If the power supply cord to the heat pump unit is damaged, they must be replaced by an authorised person in order to avoid a hazard.

Use the following guide to avoid the need for an unnecessary service call.

<b>INSUFFICIENT OR NO HOT WATER</b>	
<b>Heat Pump Unit Not Powered</b>	Check to ensure the electric isolating switch at the switchboard (usually marked "Hot water" or "Water heater" is turned on. (note that the compressor will not start up for 1 minute after power is turned on).
<b>Excessive hot water consumption</b>	Often end users are surprised at the amount of hot water used, especially when showering. If the amount of hot water used during the day exceeds the storage capacity of the cylinder, it is likely there will be insufficient hot water.
<b>Pressure &amp; Temperature Relief (PTR) Valve continually discharging water</b>	<p>It is normal and desirable that this valve allows a small quantity of water to be discharged during the heating cycle. If it discharges more than a bucket of water during a 24 hour period or discharges continuously there may be another problem.</p> <p>If the valve dribbles continuously, try easing the valve gear for a few seconds as described in the section the section 'Excessive Discharge from Safety Devices' on page 9. This may dislodge any foreign matter and alleviate the problem.</p> <p>If the valve discharges at high flows, especially at night, it may be as a result of the water pressure exceeding the design pressure of the water heater. Ask your installer to fit a Pressure Limiting Valve (PLV).</p>
<b>Expansion Control Valve (ECV) continually discharging water</b>	<p>It is normal and desirable that this valve allows a small quantity of water to be discharged during the heating cycle. If it discharges more than a bucket of water during a 24 hour period or discharges continuously there may be another problem.</p> <p>If the valve leaks continuously, try easing the valve gear for a few seconds as described in the section the section 'Excessive Discharge from Safety Devices' on page 9. This may dislodge any foreign matter and alleviate the problem. If this does not alleviate the problem contact Rinnai.</p>
<b>Ambient conditions too hot</b>	To protect the components of the heat pump unit it may not operate when the ambient temperature is higher than 50°C. The auxiliary booster if installed, will operate if water heating is required, but may take longer to heat the water.
<b>Ambient conditions too cold</b>	To protect the components of the heat pump unit, it may not operate when the ambient temperature is less than 0°C. The auxiliary booster if installed, will operate if water heating is required, but may take longer to heat the water.
<b>NO WATER FROM THE TAP</b>	
<b>Restriction in the hot tap or failure of the cold water supply to the water heater</b>	Check for water flow at the other taps and that the cold water isolation valve is fully open.

<b>HIGH ELECTRICITY BILLS</b>	
<b>Excessive hot water consumption</b>	See entry under the heading 'Insufficient or no hot water'
<b>High Electricity Tariffs</b>	The electricity tariff will determine the running costs of the system. It is important the end user is aware of the applicable tariffs. Contact your electricity supplier to confirm what these tariffs are.
<b>Higher Element Usage</b>	In extremely cold conditions the element may be operating more than normal.
<b>WATER FLOW FLUCTUATIONS</b>	
<b>High demand of hot water at the same time</b>	High demand of hot water in use at the same time may cause a decrease in the hot water flow from the taps.  Check total heating capacity of water heaters meets the highest demand of hot water in the building.
<b>WATER HAMMER</b>	
<b>Hot and cold water plumbing in the premises</b>	Have a plumber check clipping of hot and cold water pipe work and install a pressure limiting valve and water hammer arrestor as required.
<b>HEAT PUMP ICES UP</b>	
<b>Defrosting function</b>	The heat pump has a built in reversing defrosting function which may operate and remove any ice.
<b>HEAT PUMP ERROR INDICATOR</b>	
<b>Red alarm code is showing on the Display</b>	This will appear if an error is detected with the heat pump operation, please call Rinnai for assistance if this should occur.

# SPECIFICATIONS

## SYSTEM SPECIFICATIONS

Model	-	CHP020	CHP040
Voltage/Phase	-	400-415V/3Ph+N/50Hz	
Heating Capacity <sup>[1]</sup>	kW	20.0	39.5
Power Input <sup>[2]</sup>	kW	4.7	9.6
COP	-	4.25	4.10
Maximum Input Power	kW	9.0	18.5
Maximum Input Current	A	17.5	40.0
Recommended Circuit Breaker Rating	A	25	50
Recommended Conductor Cross-sectional Area	mm <sup>2</sup>	2.5	6.0
WaterMark Certified	-	Yes	
Operating Range (ambient)	°C	0 ~50	
Refrigerant System	Type	R513A	
	No. of Circuits	1	
Compressor	Type	Scroll	
	Qty	1	
Fan	Type	Hybrid Axial	
	Speed Control	Variable Speed	
	Qty	2	
Air Heat Exchanger	Type	Fin-tube protective coating	
	Qty	1	1
Nominal Airflow	L/s	2500	4470
Water/Refrigerant Heat Exchanger	Type	Double Wall Stainless steel	
	Qty	1	2
Throttle	-	Electronic Expansion Valve	
Defrost	-	Reverse Operating	
Rated Sound Power	dB(A)	66.6	68.7
IP Grade	-	IPX4	
Water Pump	Model	CM 3-2	CM 10-1
	Power Supply	1PH240V~50Hz	
	Outer Water Head (m)	10	8
Water Connections	-	R 1¼ MBSP	R 2 MBSP
Rated Water Pressure	kPa	1000	
Supply Water Pressure Maximum	kPa	800	
ECV Fitted	Fit PLV if mains pressure exceeds	680 kPa	
	Recommended PLV pressure rating	500 kPa	
ECV Not Fitted	Fit PLV if mains pressure exceeds	800 kPa	
	Recommended PLV pressure rating	500 kPa	
Maximum Temperature Setting	°C	65	
Dimensions	Height (mm)	1162	1442
	Width (mm)	730	850
	Length (mm)	1550	2050
Nominal Weight <sup>[3]</sup>	Kg	236	360

[1] Test condition: 20°C ambient / 60% RH. 39°C water in / 45°C water out.

[2] Water pump power is not included

[3] For base model only. Factory options will vary.

SPECIFICATIONS

DIMENSIONS

Description		Dimensions (mm)						
Model	Version	A	B	C	D	E	F	G
CHP020	Top Discharge	1162	730	1550	1288	809	1590	-
	Side Discharge	1162	730	1550	-	809	1590	895
CHP040	Top Discharge	1442	850	2050	1565	928	2100	-
	Side Discharge	1442	850	2050	-	928	2100	1011

Top Discharge Unit

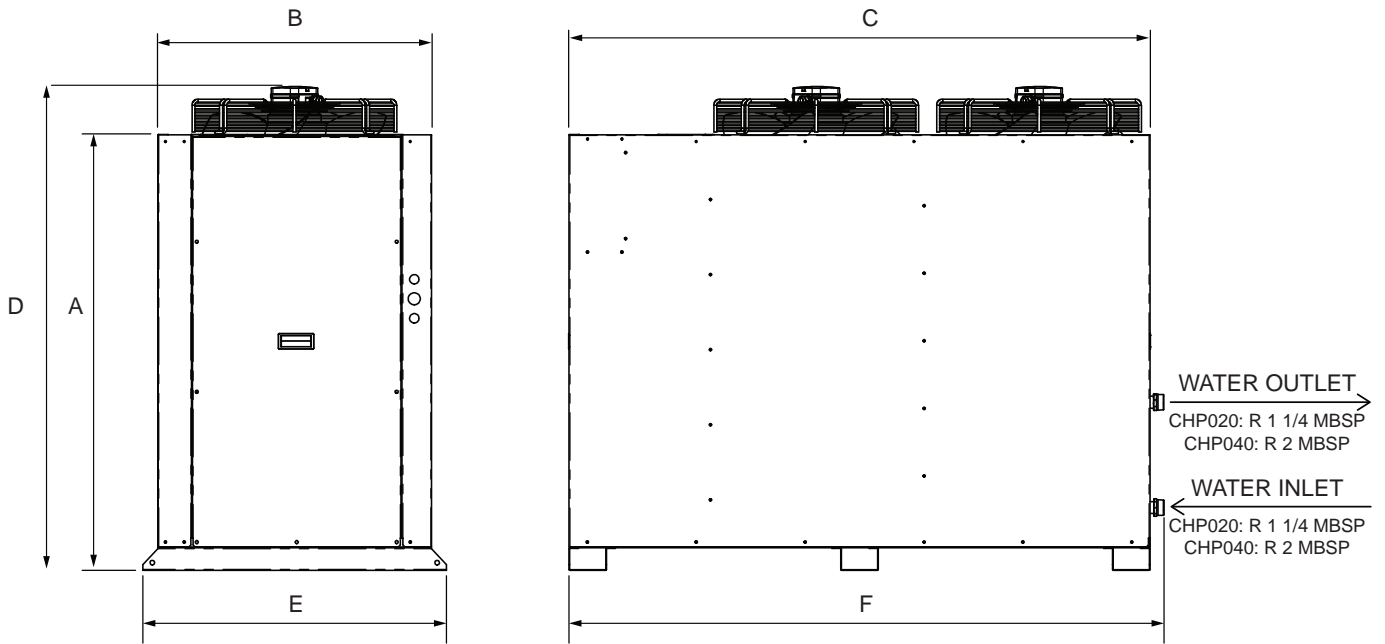

Side Discharge Unit

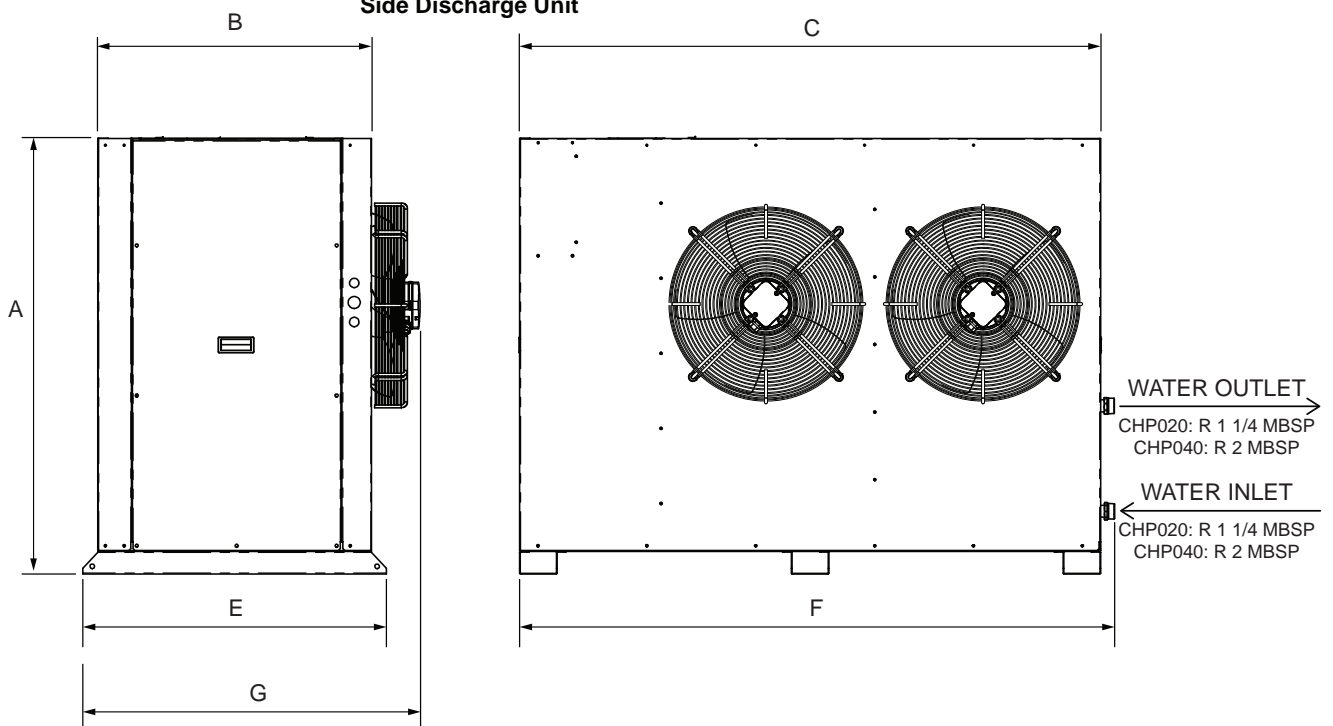

CLEARANCES

Description		Dimension(mm)					
Model	Version	A	B	C	D	E	F
CHP020	Top Discharge	850	500	1000	500	1500	-
	Side Discharge	850	500	1000	500	-	1500
CHP040	Top Discharge	850	650	1000	600	1800	-
	Side Discharge	850	650	1000	600	-	1800

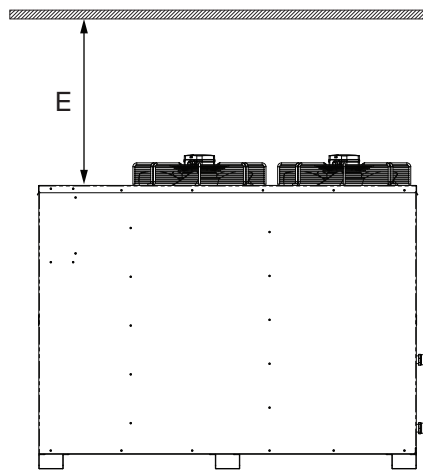
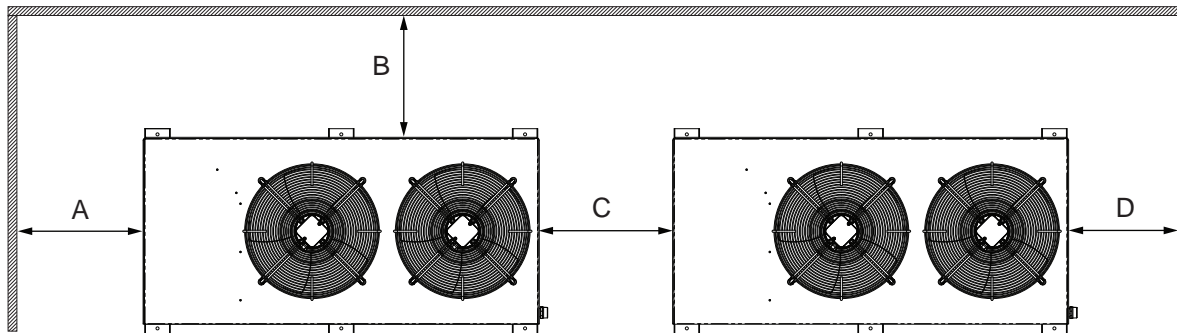

Top Discharge Unit

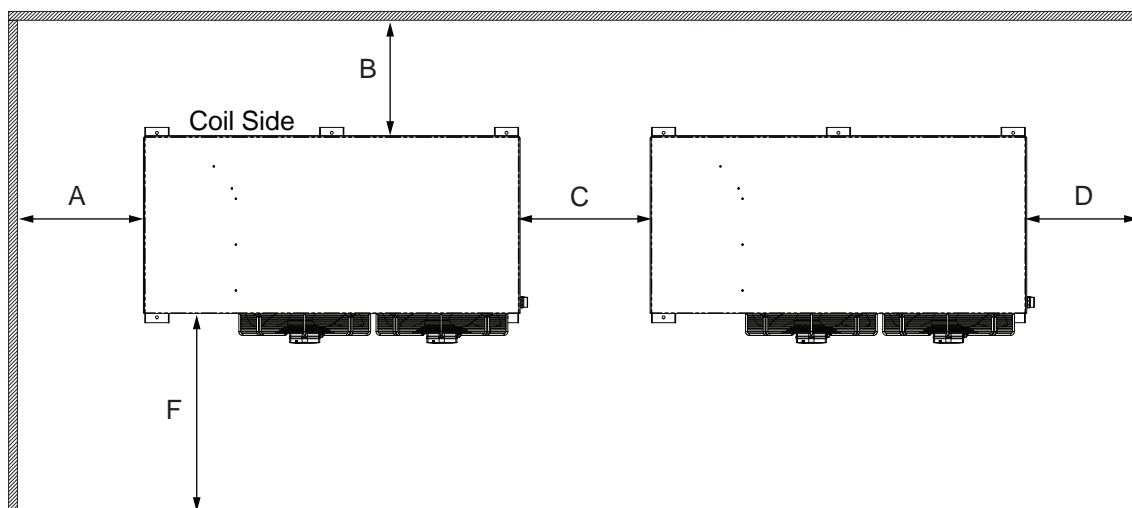

Side Discharge Unit

UNIT MAIN COMPONENTS OVERVIEW

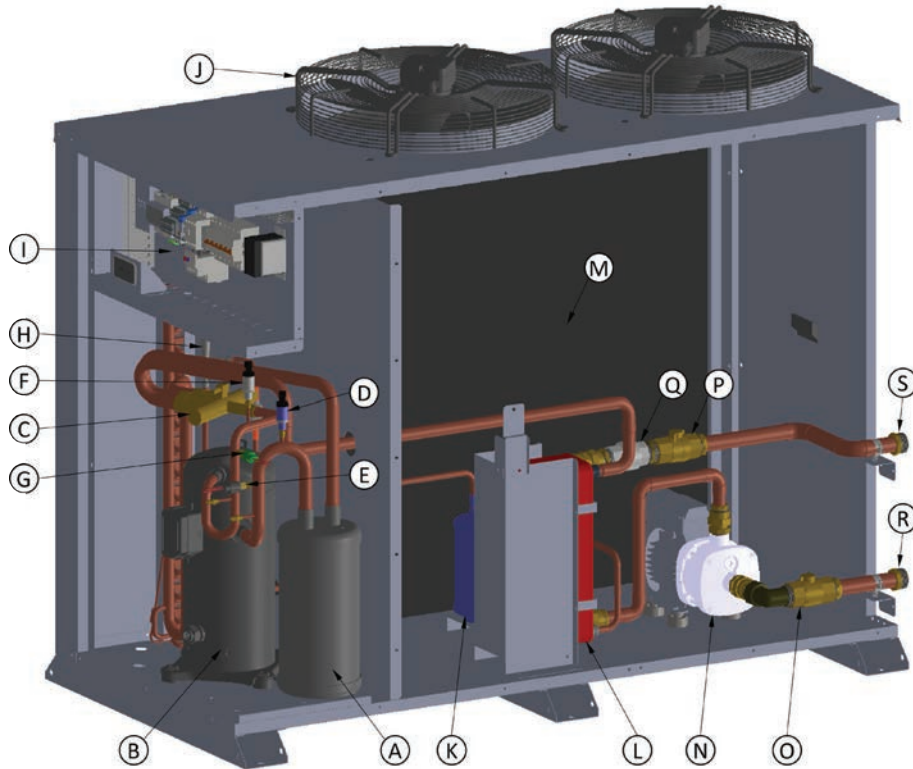

Item	Description
(A)	Accumulator
(B)	Compressor - Scroll
(C)	Reversing Valve
(D)	Low Pressure Transducer (0-10Bar)
(E)	Low Pressure Switch
(F)	High Pressure Transducer (0-30Bar)
(G)	High Pressure Switch
(H)	Electronic Expansion Valve
(I)	Switchboard
(J)	Fan
(K)	Liquid Receiver
(L)	Plate Heat Exchanger
(M)	Evaporator Coil
(N)	Water Pump
(O)	Ball Valve - Water Inlet
(P)	Ball Valve - Water Outlet
(Q)	Non-return Valve
(R)	Water Inlet Bush
(S)	Water Outlet Bush



## MAIN ELECTRIC COMPONENTS IN SWITCHBOARD

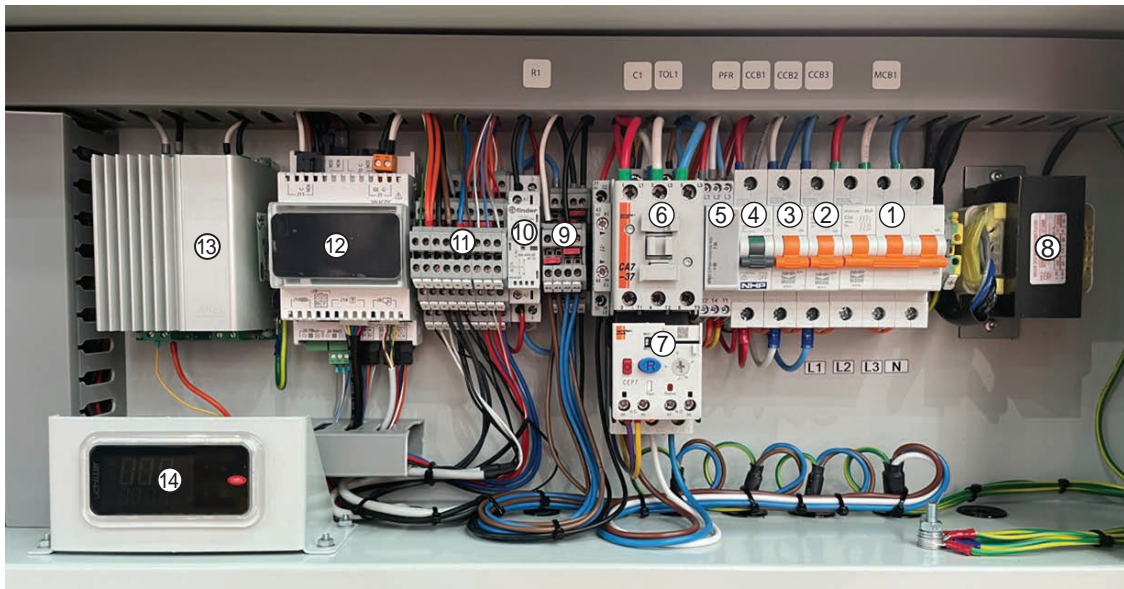

Item	Description
①	Main Breaker - Field Wiring
②	Breaker - Water Pump
③	Breaker - Fan
④	Breaker - Controller
⑤	3 - Phase Fail Relay
⑥	Contactor - Compressor
⑦	Electronic Overload
⑧	Transformer
⑨	Terminals - Pump, Fan
⑩	Relay - Water Pump
⑪	Terminals - Tank Sensor
⑫	Main Controller
⑬	Fan Speed Controller
⑭	User Interface

# INSTALLATION

## REGULATIONS AND OCCUPATION HEALTH AND SAFETY (OH&S)



**Installation and commissioning MUST be performed by authorised persons.**

**The heat pump MUST be installed in accordance with these instructions and all regulatory requirements which exist in your area including those in relation to manual lifting.**

**Applicable publications and regulations may include:**

- **AS/NZS 3500 National Plumbing and Drainage**
- **AS/NZS 3000 Wiring Rules**
- **Plumbing Code of Australia (PCA)**
- **Building Codes of Australia (BCA)**
- **Local Occupational Health and Safety (OH&S) regulations**

**This appliance is not suitable for use as a domestic spa pool or swimming pool heater.**

**Electric Heat pumps are heavy and bulky items. Australian States and Territories have a Principal Occupational Health and Safety (OH&S) Act which contains requirements relating to the handling of large, bulky or awkward items. Persons installing heat pump systems MUST be aware of their responsibilities and be adequately trained and qualified, in accordance with local OH&S requirements.**

## LOCATION

The electric heat pump can be installed externally or internally.

The electric heat pump should be placed as close as practicable to the most frequently used hot water outlet point or points to minimise the delay time for hot water delivery. For installations where the distance between the heat pump and the outlets is considerable, a flow and return system can be used which minimise the waiting time for hot water delivery.

It is recommended that all components are installed at ground or floor level. The heat pump MUST be installed in a vertically upright position. All components MUST be accessible without the use of a ladder or scaffold.

The air inlet and outlet of the heat pump module MUST be away from areas with strong wind and MUST be provided with sufficient clearances as per those shown in the section "Clearances" on page 15

The heat pump MUST be connected to an independent AC 415V, 50Hz power supply.

Ensure the pressure and temperature pressure relief (PTR) valve and any access covers have sufficient clearances and are accessible for service and removal. The information on the rating plates MUST also be readable.

The heat pump MUST be installed free-standing on a level and stable base. The storage tank should be mounted on a concrete base at least 50mm thick or on well-seasoned, evenly spread hardwood slats with a thickness of at least 25mm. Where property damage can occur as a result of water leakage, the storage tank MUST be installed with a safe tray (overflow tray) and drain in accordance with AS 3500.4. Ensure the storage tank DOES NOT stand on wet surfaces.

## Internal Installation

For internal installations the area MUST meet the following requirements:

- Good ventilation to ensure heat pump work properly and efficiently.

If the heat pump is installed internally careful consideration should be taken in regards to positioning and limiting the effect of unit noise and reverberation during operation.

## Condensation

As this heat pump is highly efficient the surrounding air temperature could be cooled by up to 0°C and condensate formed, the condensate will need to be plumbed to a suitable drain.

## Drainage

Where property damage can occur as a result of water leakage, the water heater MUST be installed with a safe tray (overflow tray) and drain. Construction, installation and draining of the safe tray MUST comply with local regulatory requirements and AS/NZS 3500.4 also requires the use of a safe tray for particular situations.

## WATER SUPPLY

The maximum water pressure is listed on page 13. An approved pressure limiting valve may be required if the maximum rated water supply pressure is exceeded.

Water chemistry and impurity limits are detailed in the separate warranty document. Most metropolitan water supplies fall within these requirements. If you are unsure about water quality, contact your water authority.

A water filter **MUST** be fitted on the inlet to the tank to prevent sludge or foreign matter entering the system.

In a scaling water supply, calcium carbonate and possibly other compounds are deposited out of the water onto any hot metallic surface and form a scale. Scaling water may cause scale deposits to form onto the metallic surfaces of the PTR valve and may prevent it from operating properly. To prevent this, an expansion control valve (ECV) **MUST** be fitted on the cold water line after the non-return valve in areas of scaling water. ECVs' **MUST** be fitted in South Australia and Western Australia to comply with local regulations.

## STORAGE TEMPERATURE

To meet regulatory requirements the thermostat control on the heat pump water heater is factory pre-set to heat all the water in the tank to 65°C.

## HOT WATER DELIVERY TEMPERATURE

This appliance may deliver water at high temperature. Refer to the Plumbing Code of Australia (PCA), local requirements and installation instructions to determine if additional delivery temperature control is required.

The PCA, local regulations and the requirements of AS/NZS 3500.4 **MUST** be considered regarding the temperature limitations of hot water supplied to areas used primarily for personal hygiene.

The temperature of water to certain areas is limited to different temperatures according to purpose, for e.g. early childhood centres, primary and secondary schools and nursing homes or similar facilities for young, aged, sick or people with disabilities and for all other buildings. To comply with these requirements, a temperature limiting device, such as a thermostatic mixing or tempering valve, will be required on hot water systems.

## VALVES AND FITTINGS

The following valves and fittings should be supplied with your heat pump system:

- A combined pressure and temperature (PTR) relief valve. This valve is fitted at the top of the storage tank. The PTR valve is a safety device and it is mandatory that it is fitted by the installer in all installations.

The following valves & fittings are to be supplied by the installer:

- A cold water expansion control valve (ECV). An ECV **MUST** be fitted in Western Australia and South Australia to the cold water supply to the storage cylinder to comply with local regulations. An ECV is recommended in all other geographical areas where the water supply has a tendency to cause scaling. This will reduce hot water discharge from the pressure and temperature relief (PTR) valve which minimises wear on this valve.
- A stop cock, non return valve and line strainer. Combination valves incorporating two or more of these functions (such as 'Trio' valves) are suitable. These are fitted to the cold water supply to the storage tank by the installer.
- Cold water supply and hot water discharge pipework to and from the storage tank. This pipework **MUST** be insulated as specified in AS/NZS3500.4.
- An approved pressure limiting valve is required if the maximum rated water supply pressure on page 13 is exceeded.
- Tempering valve(s) or thermostatic mixing valve.

POSITIONING THE HEAT PUMP

- Arrive at site and conduct a safety audit (Safety audits can also be known as Work Method Statements (WMS) or Job Site).
- Analysis (JSA).
- Park your vehicle as close as allowable to your installation. Unload all materials in a safe manner.
- Position all materials in a convenient position near the work area.
- The heat pump is designed to be installed outdoors or indoor if a sufficient supply of heat energy and good ventilation is available. Good performance is obtained when the heat pump is supplied with a constant supply of fresh air. Failure to meet above recommendations may lead to lower performance or problematic operation of the heat pump.
- The location **MUST** consider noise impact on living areas. Avoid positioning near bedrooms or neighbours' bedrooms.
- Adequate access **MUST** be available for servicing of the heat pump. Refer to clearance requirements specified in the section 'clearances'. The water heater must be accessible without the use of a ladder or scaffold.
- The water heater **MUST** not be installed in an area with a corrosive atmosphere where chemicals are stored or where aerosol propellants are released.
- Safely position the new unit on a level surface in accordance with all plumbing and building regulations. Use M10 foot bolts to firmly secure the unit.
- A properly drained overflow tray **MUST** be used where property damage could occur from water spillage. (See AS/NZS3500.4.2 for further details.)

INSTALLATION DIMENSIONS

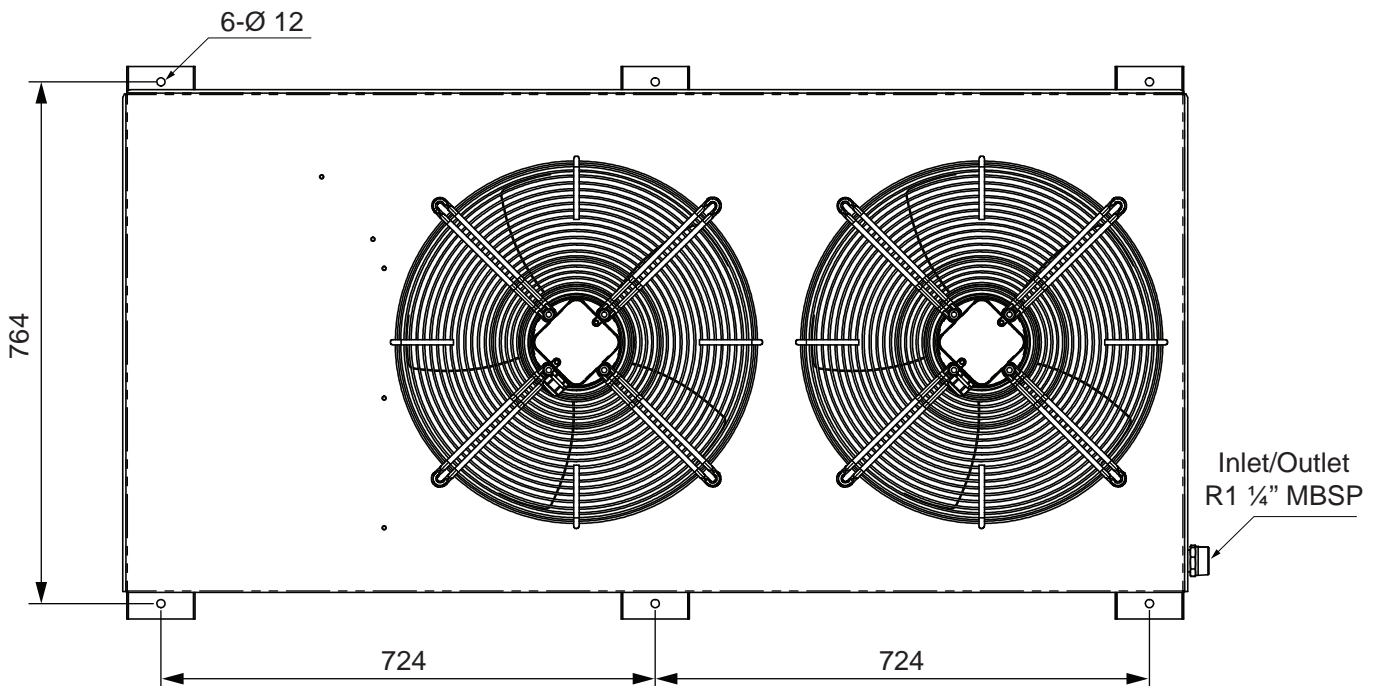

CHP020 Installation Dimension

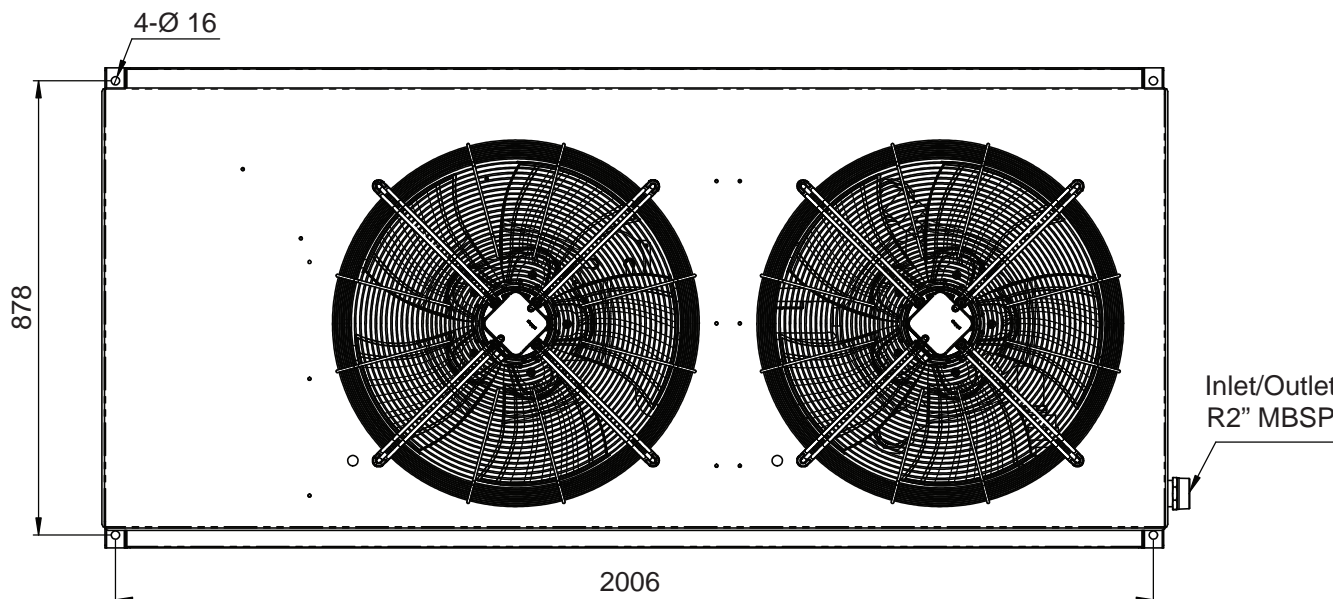

**CHP040 Installation Dimension**

#### CONNECT THE PTR VALVE

Connect the PTR valve to the uppermost fitting of the storage tank. See the diagram on the tank user manual.

The PTR pressure rating **MUST** be suited for the tank and adequate for the thermal loading applied to the storage tank. Use Teflon thread tape on the valve, never use hemp or other sealing materials. Ensure the tape does not protrude past the end of the thread, which could result in it hanging over the end of the thread and blocking the water passage through the valve.

Connect the supplied PTR valve into the top socket marked 'Relief Valve' and discharge according to plumbing regulations. PTR Valves for the unit are rated at 1000kpa.

The drain line from this valve **MUST** run in a continuously downward direction with the discharge end left permanently open to atmosphere.

#### PLUMBING CONNECTIONS

The heat pump water heater system comprises three main components: the heat pump water heater, storage tanks and primary circulator. An auxiliary booster and/or circulator may also be employed as part of the system. The water heater must not be operated until all components are assembled.

An approved isolating valve, non return valve, line strainer, and union **MUST** be fitted between the supply main and the tank. All fittings **MUST** be approved by the relevant installation Authority.

An ECV **MUST** be fitted in Western Australia and South Australia to the cold water supply to the storage tank to comply with local regulations.

An ECV is recommended in all other geographical areas where the water supply has a tendency to cause scaling.

This will reduce hot water discharge from the pressure and temperature relief (PTR) valve which minimises wear on this valve.

This water heater is designed for direct connection to water supply pressures of no greater than those specified on page 13. Where the mains pressure can exceed or fluctuate beyond this, a pressure limiting device (complying with AS1357) **MUST** be fitted.

Refer to the following table "Minimum Pipe Sizing" on page 22 for sizing. Header pipe sizing is based on a total length of 40m of primary discharge and return piping and 20 x 90° bends with 1.2m/sec velocity.

Evaluate total pressure drop from discharge to return piping and ensure. It is less than heat pump maximum outer water head stated in section "System Specifications" on page 13. If this specification is exceeded, please consult Rinnai before installation.

Up to ten storage tanks can be manifolded together in water loop. The storage tanks must be of the same model.

Inlet and outlet water isolation valves should be installed at each heat pump to enable each heat pump to be individually isolated for servicing. It is strongly recommend to install a suitable strainer in the inlet pipe for each heat pump.

**Minimum Pipe Sizing**

CHP020				
No. of Heat Pumps in Parallel	1	2	3	4
Pump	Grundfos CM 3-2			
Branch Size (mm)	32			
Header Size (mm) (Primary Piping)	40	50	65	80

CHP040				
No. of Heat Pumps in Parallel	1	2	3	4
Pump	Grundfos CM 10-1			
Branch Size (mm)	50			
Header Size (mm) (Primary Piping)	50	80	100	100

**EQUAL FLOW PRINCIPLE**

Multiple heat pumps **MUST** be installed using equal flow principle to ensure the demand on each heat pump (or storage tank) is the same as any other. To achieve this, the following is necessary:

- The inlet and outlet manifolds shall be designed to balance the flow to each heat pump (i.e. each branch line must be the same diameter and length).
- The manifolds shall be designed to ensure the flow; the first heat pump in shall be the last heat pump out.

Storage tanks **MUST** be manifolded using equal flow principle to ensure even distribution of the stored energy. To achieve this, the following is necessary:

- The cold water, primary flow and hot water manifolds shall be designed to balance the flow for each storage tank (i.e. each branch line shall be the same diameter and length).
- The manifolds shall be designed to ensure the flow: the first storage tank in shall be the last storage tank out.

TYPICAL INSTALLATIONS

Commercial Heat Pump  
Standard Installation with Re-circulation

ELEVATION VIEW

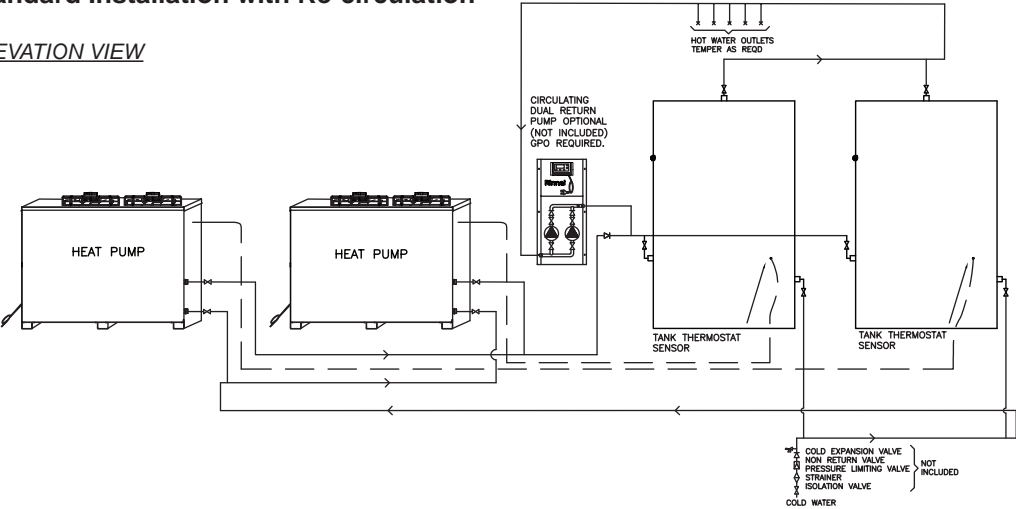

PLAN VIEW

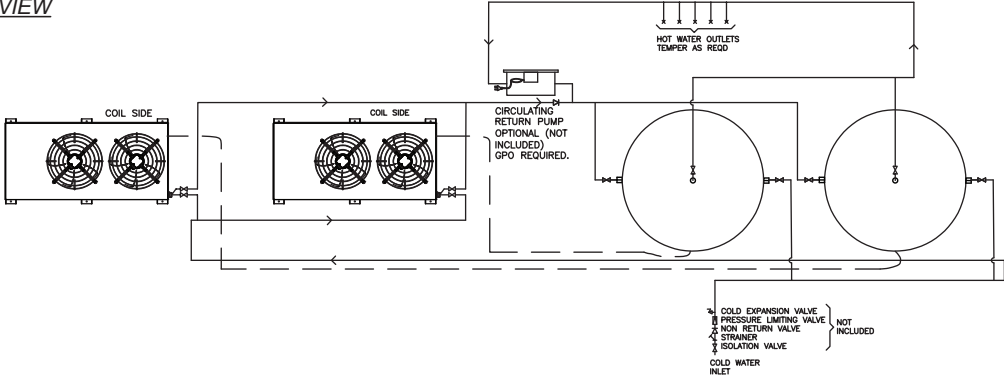

Commercial Heat Pump  
Standard Installation with Storage & Electric Boost

ELEVATION VIEW

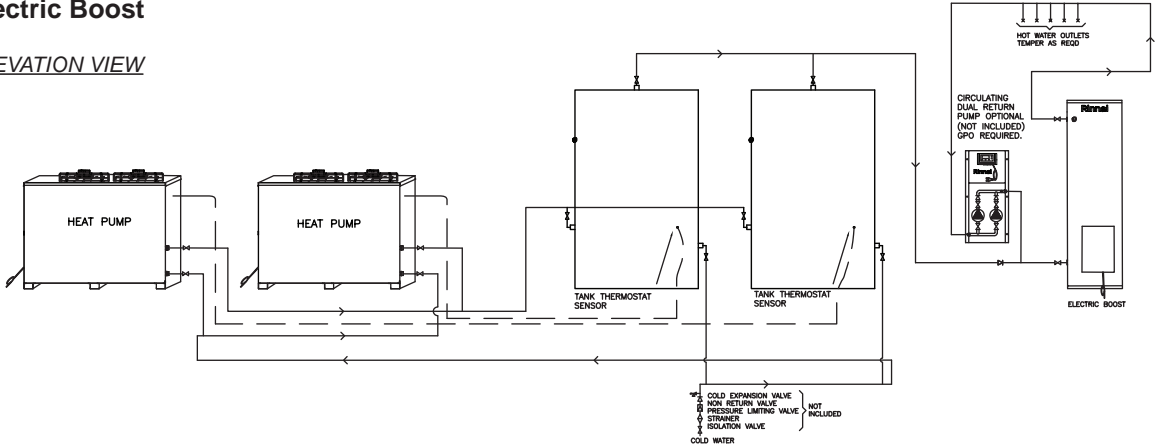

PLAN VIEW

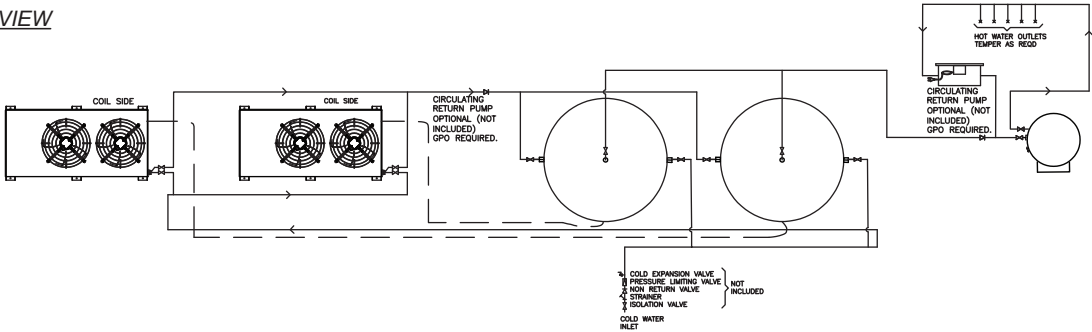

**CONNECT COLD / HOT WATER SUPPLY**

Connect cold water supply, Pressure Limiting Valve (PLV) and or Expansion Control Valve (ECV).

Connect cold water supply to the storage tank (refer to Diagram below).

A stop cock, non return valve and line strainer **MUST** be fitted.

Isolating Valve (Spindle Vertical)

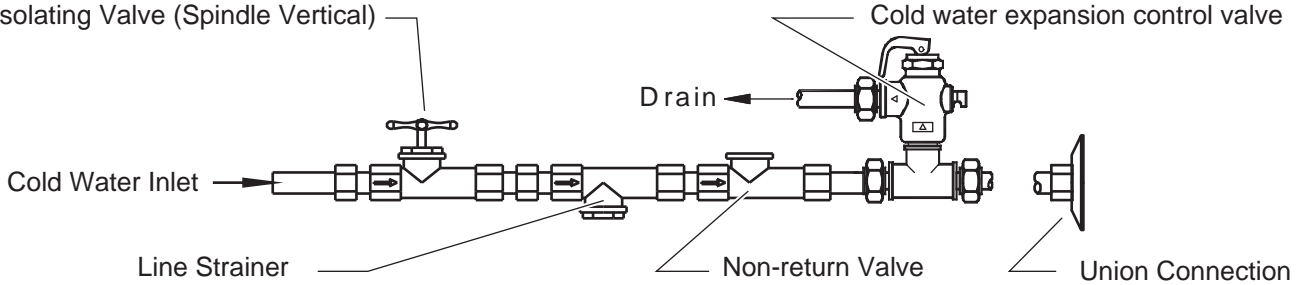

Connect the pipe work supplying hot water to the premises to the hot water outlet on the tank.

Connect the pipe work between the heat pump and the tank.

A temperature limiting device may be required as detailed in the section ‘Hot Water Delivery Temperature’.

It is recommended that all hot water lines are insulated with high temperature, UV resistant 13mm closed cell insulation.

**ELECTRICAL TESTS**

DO NOT turn on the power supply to the appliance until it has been filled with water and a satisfactory insulation (Megger) test has been performed.

Conducting Insulation (Megger) Tests

When conducting an insulation test using a Megger on this appliance, observe the then the following:

 **WARNING** This appliance contains electronic components, when performing insulation tests (500 Volts) this **MUST ONLY** be conducted the across active terminal to earth and then across the neutral terminal to earth.

**Tests between the active to neutral terminals MUST NOT be performed as this WILL damage the electronic components.**

An insulation test result of above **1 MΩ** should be obtained for this water heater.

**ELECTRICAL CONNECTIONS**

 **WARNING** The power supply to the heat pump module **MUST NOT be activated until the system is filled with water.**

The premises wiring to the heater **MUST be capable of withstanding the appliance load. Refer to specification table for load details.**

All electrical connections and wiring **MUST be installed, maintained and removed by authorised persons in accordance with AS/NZS 3000, and all other relevant local regulations and municipal building codes including OH&S requirements.**

**Disconnect all power prior to installation and commissioning.**

Main Power

 **IMPORTANT** The heat pump water heater must be directly connected to a 415 V AC 50 Hz mains power supply. The heat pump must be on its own circuit with an isolating switch installed at the switchboard. A secondary isolating switch must be installed within reach of the water heater.

**Connect all ACTIVE and NEUTRAL wires in accordance with the wiring diagram. Ensure the incoming EARTH wire is securely fixed to the earth post.**



## Primary Pump

For those units without pump stalled inside the unit, the power to the primary pump for each heat pump is supplied from the unit. Connect the active, neutral and earth wire to the pump terminals located within the heat pump electrical enclosure marked “A3” and “N” as shown below.



**For those units integrating pump inside the unit, please skip this step.**

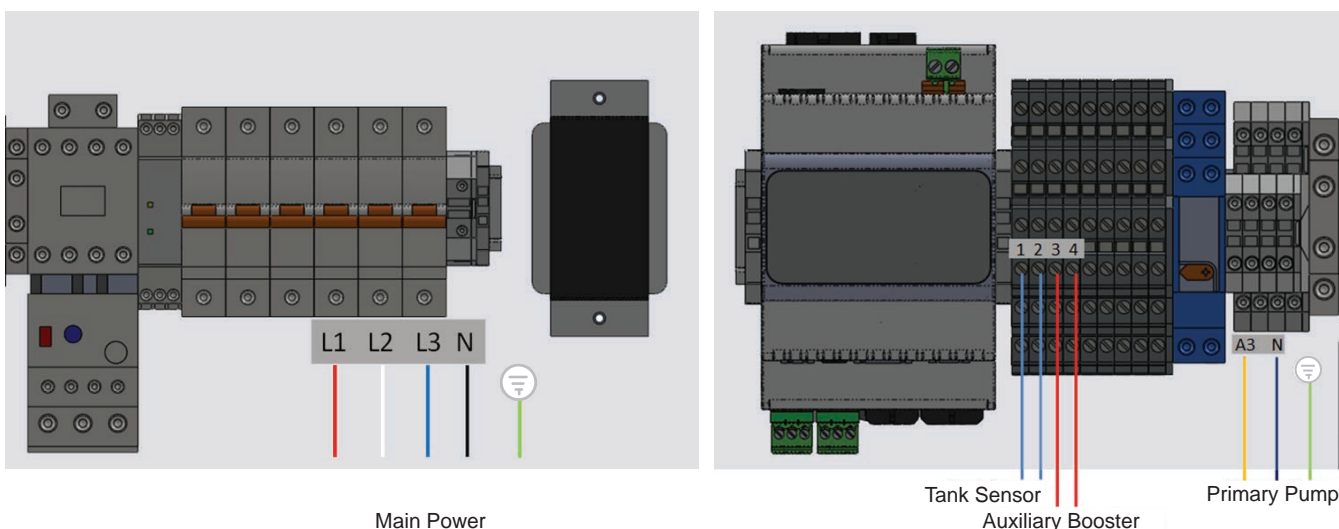

## Tank Sensor Installation

Connect the supplied temperature sensor to the connection terminal marked “1” and “2” (as shown above right) located within the electrical enclosure. Run out the sensor to the nearest storage tanks and insert the sensor to the thermostat well. **MUST** apply heat transfer sealant to the well prior to insert the sensor.

Ensure the sensor is securely fitted to the well in the tank (see right).

Each Heat Pump should connect a temperature sensor.

## Auxiliary Booster (optional)

If auxiliary booster control box is not provided, please skip this step.

Depending on the installation, an auxiliary booster control box may be supplied for supplementing heat at low ambient temperature. Terminals “3” and “4” provide a power free signal to control the auxiliary booster (as shown above right). Use a minimum 0.75mm<sup>2</sup> two-core cable (provided by installer) to wire to auxiliary booster control box terminals. Refer the electric diagram of control box for wiring between the control box and auxiliary booster.

The auxiliary booster has been interlocked with the heat pump to only operate under low ambient or fault conditions.

- When ambient temperature falls below 5°C, auxiliary booster is activated. The auxiliary booster will operate until the set point reaches. Auxiliary booster will remain active until the ambient temperature reaches above 7°C. Heat pump and auxiliary booster may work simultaneously.
- When ambient temperature falls below 0°C, heat pump is deactivated. Heat pump won't activate until the ambient temperature reaches above 2°C. Only the auxiliary booster will operate until the set point reaches.
- When heap pump is in fault, auxiliary booster will operate instead of the heat pump until the set point reaches. Auxiliary booster will remain active until the heat pump fault is cleared.

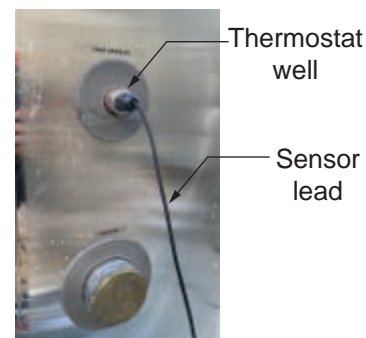

## FILLING THE SYSTEM AND COMMISSIONING

If the heat pump is full of cold water, SWITCH ON the electrical supply at the isolating switch to the heat pump, and SWITCH ON all breaks in the switchboard. The heat pump will start to heat up tanks automatically unless the ambient temperature is below the ambient sensor set point, in which case the auxiliary booster will operate, if installed.

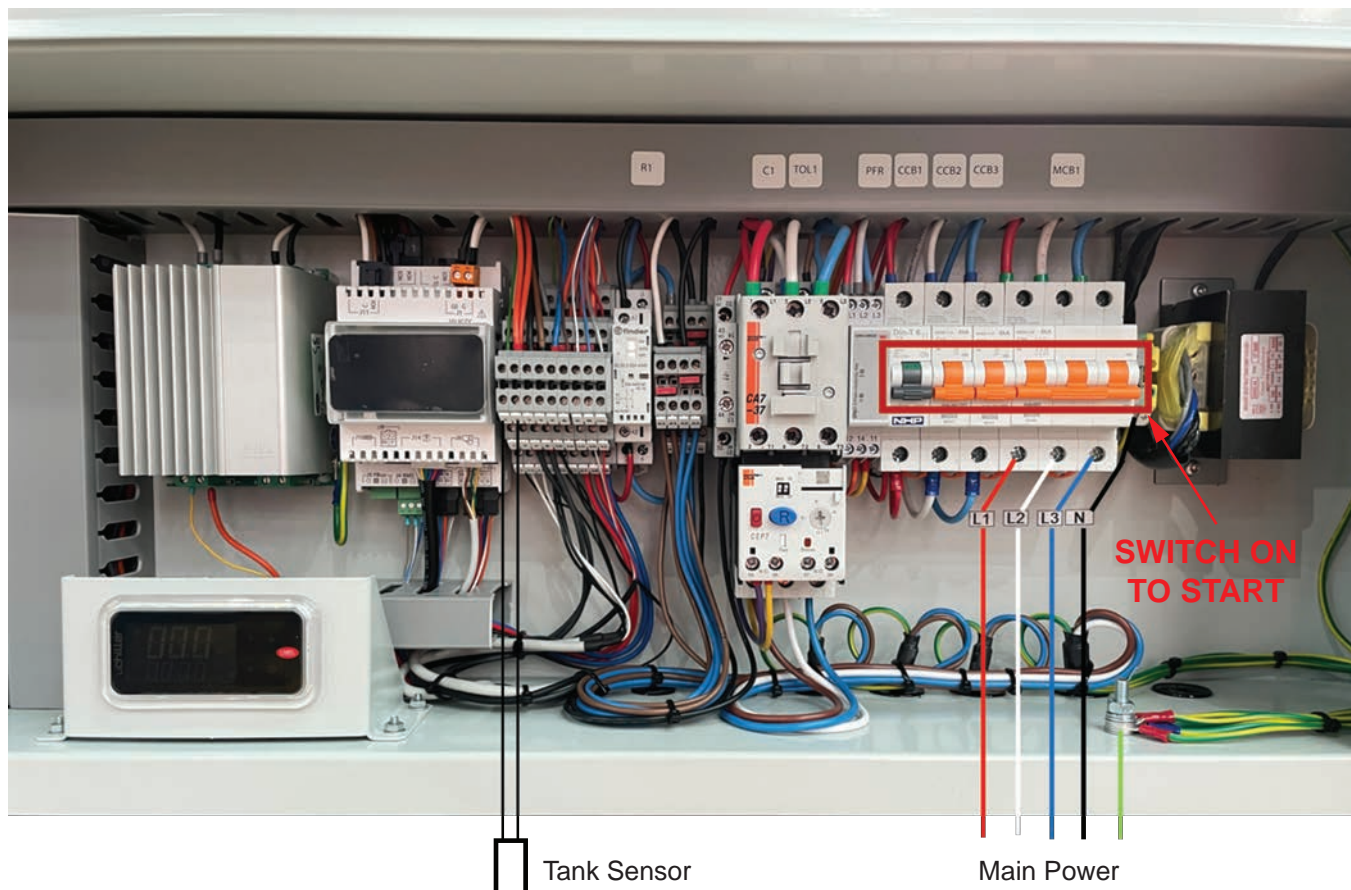

When the power supply turns on, the heat pump control system initiates and will check the unit's operating parameters. The controller will check on all sensors, pressure switches and transducers and also main voltage. If conditions are suitable (i.e all reading within the reasonable range) and there is enough energy available in the surrounding air, the fan, circulating pump and compressor will turn on. If not enough energy is detected in ambient air then the controller calls for the auxiliary booster (if installed) to run.

There will be a delay of half minute from the time the main power is switched on before the pump, fan and compressor start operating.

The unit is self regulating so there are no internal adjustments to be made during commissioning. When the unit is operated for the first time, it runs through an initial heat up cycle, allow time for the initial heat up cycle. Depending on the ambient conditions this can take several hours.

Once its first heat up cycle is complete, the tank water temperature will be approximately 65°C. The heat pump will run standby mode and the compressor will activate automatically once the tank temperature falls below threshold (around 60°C). During standby, only water pump operates intermittently so as to save energy.

If for any reason the unit does not start, the water is cold and the controller unit is not displaying any LED lights, an electrician should test that power is available to the heat pump. If there is an alarm code displaying, please refer to the section "Alarm Codes & Troubleshooting" on page 31 for troubleshooting.

Allow heat pump operating 1 hour or longer, check if tank temperature is rising and there is any alarm codes displaying, then complete the section "Commissioning Log & Checklist" on page 32.

### FINISHING THE INSTALLATION

After testing is completed explain to the responsible officer the functions and operation of heat pump water heater components. Explain to the responsible officer the need to drain the heat pump if freezing conditions are likely and power is likely to be shut off.

Also explain to the responsible officer the importance of carrying out maintenance in accordance with this manual.

Leave this manual with the responsible officer.

## USER TERMINAL

The user terminal includes the display and keypad, comprising four buttons that, when pressed alone or combined with other buttons, access the operations available for the 'User' profiles. The heat pump uses the user terminal to display the alarms, the main variables and to set the unit set points.

Key	
1	Keypad
2	Main Field
3	Device status and operating mode icons

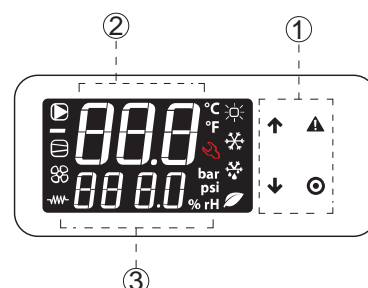

### Keypad

Ensure the controller unit is not displaying the ERR indicator once unit has been switched on.

Button	Description	Function
	UP	<ul style="list-style-type: none"> <li>When scrolling - go to the previous parameter</li> <li>In programming mode - increase the value</li> </ul>
	DOWN	<ul style="list-style-type: none"> <li>When scrolling - go to the next parameter</li> <li>In programming mode - decrease the value</li> <li>Main menu:                             <ul style="list-style-type: none"> <li>- press briefly - unit dashboard display</li> <li>- press and hold (3 secs) - access User parameters (set point, unit ON / OFF)</li> </ul> </li> </ul>
	ALARM	<ul style="list-style-type: none"> <li>Pressed briefly - display active alarms and mute buzzer</li> <li>Pressed and held (3 secs) - reset alarms</li> </ul>
	PRG	<ul style="list-style-type: none"> <li>When scrolling - access parameter programming mode</li> <li>In programming mode:                             <ul style="list-style-type: none"> <li>- press briefly - confirm value</li> <li>- press and hold (3 secs) - return to the main menu</li> </ul> </li> </ul>

### Icons

Icon	Function	On	Flashing
	System pump	Active	In manual operation
	Source device status (pump/fan)	Active	In manual operation
	Compressor status	Active	In manual operation
	Frost protection heater	Active	-
	Operating mode	Heating	-
		Cooling	High Water Temperature
		Defrost	Dripping after Defrosting
		Free cooling	
	Service	Service request on exceeding operating hours	Serious alarm, action required by qualified personnel

The standard display shows:

- On the top row: the delivery water temperature;
- On the bottom row, when the unit is on, the tank water temperature; when the unit is off, it shows 'OFF'.

The user terminal only provides access to the basic configuration parameters, such as set point and switching unit on and off.

Operation

- 'DOWN' for 3 seconds to access the parameters
- 'UP' and 'DOWN' to scroll and set the parameters
- 'PRG' to change the parameter value and save the changes
- 'PRG' (3 seconds) or 'ESC' to return to the standard display

<p>1. Go to the standard display.</p>	<p>2. Press DOWN for 3 secs. The current set point (SEtA) is shown - Read Only.</p>	<p>3. Press DOWN. The cooling set point (SEtC) is shown.</p>	<p>4. Press PRG. The value flashes; press UP/DOWN to change the value. PRG to confirm.</p>
<p>5. Press DOWN. The heating set point (SEtH) is shown - for heat pump units only.</p>	<p>6. Press DOWN. The unit ON/OFF function (UnSt) is shown.</p>	<p>7. Press DOWN. The function for switching from cooling (C) to heating (H) mode (ModE) is shown - for heat pump units only.</p>	<p>8. Press DOWN. The manual defrost function (dFr) is shown. Service level and reverse cycle A/W units only.</p>
<p>9. Press DOWN. The function to delete the alarm log (ClrH) is shown - Service level only.</p>	<p>10. Press DOWN. The unit of measure selection (UoM) is shown.</p>	<p>11. After having completed the settings, to exit either: (a) from the categories press ESC and then PRG; or (b) press PRG for 3 secs.</p>	

APPLICA APP

The unit allows interaction with mobile devices through Bluetooth and simplifies commissioning. It is recommended that installers download the CAREL 'Applica' App to do commissioning instead of using the above user terminal.

- iOS user – please download from App Store
- Android user – please download from Google Play

Illustrated below are steps on how to download and use APPLICA from the Apple App Store. Follow similar procedure in Google Play for Android.

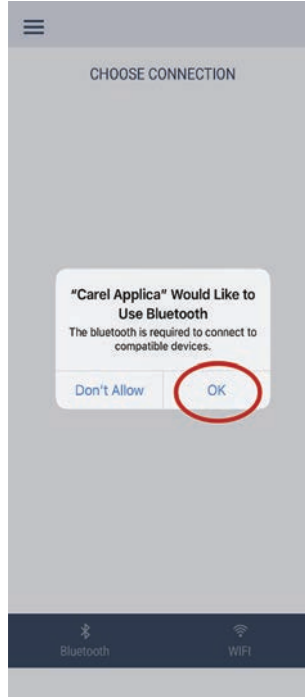
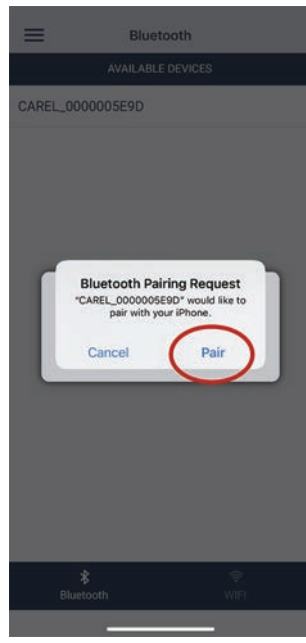
<p>Search "Applica" in APP store, install the App in your phone.</p>  <p>The screenshot shows the search results for 'Carel Applica' in the Apple App Store. The app is listed as 'Utilities' with a 'GET' button circled in red. Below the app card are promotional images and a 'Home Wizard: Personal...' app card.</p>	<p>Open the App and accept conditions and continue</p>  <p>The screenshot shows the 'EULA' (End User License Agreement) screen. At the bottom, there is a checked 'Accept' button and a 'Continue' button, both circled in red.</p>	<p>Skip setup</p>  <p>The screenshot shows the 'Welcome to Applica' screen. A 'Skip setup' button in the top right corner is circled in red. At the bottom, there is a 'Next' button.</p>	<p>Agree to use your phone's Bluetooth. <b>Make sure your phone's Bluetooth and Internet is always accessible when using this App.</b></p>  <p>The screenshot shows a system dialog asking for permission to use Bluetooth. The 'OK' button is circled in red. The text above the dialog says: '"Carel Applica" Would Like to Use Bluetooth. The bluetooth is required to connect to compatible devices.'</p>
<p>Click "Bluetooth" to find your Heat Pump ID.</p>  <p>The screenshot shows the 'CHOOSE CONNECTION' screen. At the bottom, the 'Bluetooth' option is circled in red.</p>	<p>Choose the unit you want to connect. Each Heat Pump has its own ID.</p>  <p>The screenshot shows the 'Bluetooth' screen with 'AVAILABLE DEVICES'. The device ID 'CAREL_0000005E9D' is circled in red.</p>	<p>Pair the unit with your phone</p>  <p>The screenshot shows a 'Bluetooth Pairing Request' dialog. The 'Pair' button is circled in red.</p>	<p>Wait for connection and loading. For initial connection, this step may last 2 minutes. Please keep your phone accessible to Internet.</p>  <p>The screenshot shows a 'Loading [1/4]' dialog with a progress bar at 37% and a 'Cancel' button.</p>

# TROUBLESHOOTING

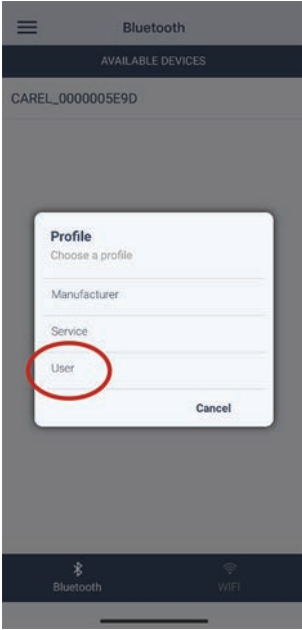
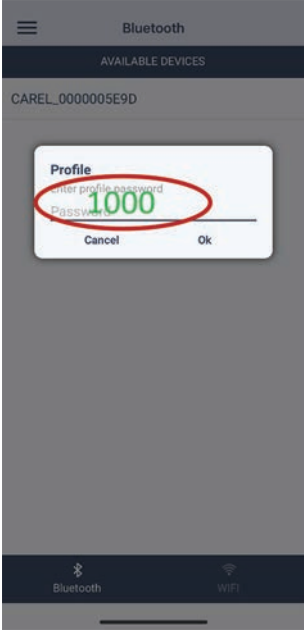
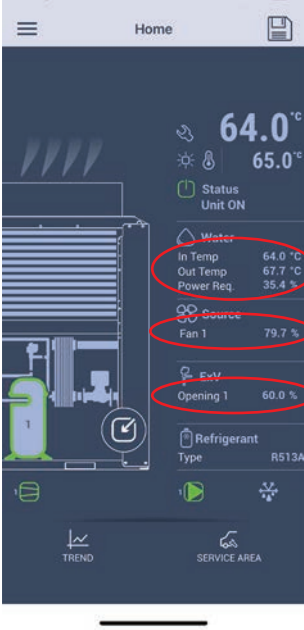
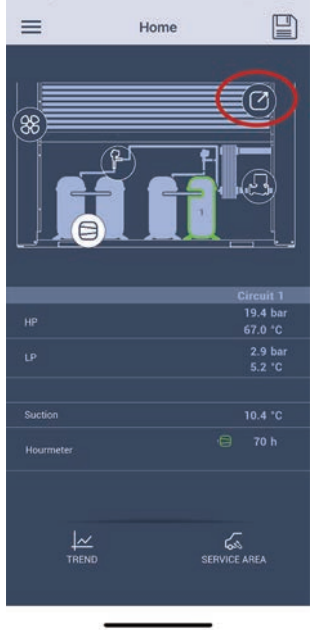
<p>Select User to login</p> 	<p>Input user password: 1000</p> 	<p>You are now successfully logged onto Applica. You can see component operation status and also check refrigeration pressure by clicking on the icon.</p> 	<p>Click this icon to return to main display</p> 
--	---	--	---

Change set point procedure:

- Access the Service menu by clicking the icon at the bottom right
- Click "Commands"--> Change set point
- After complete changing, go back to the main display, access the menu on the command bar at the top left, select 'Disconnect' to disconnect and save parameters.

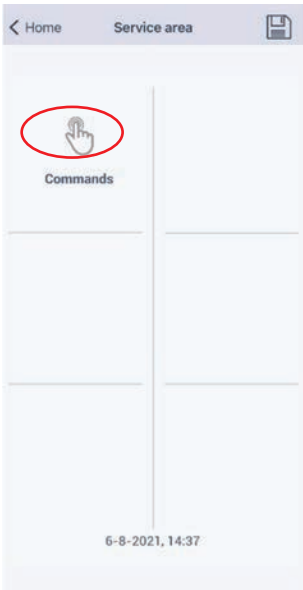
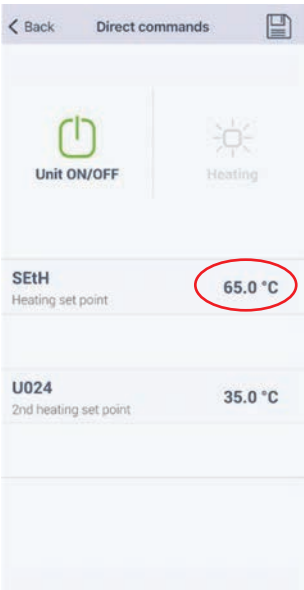
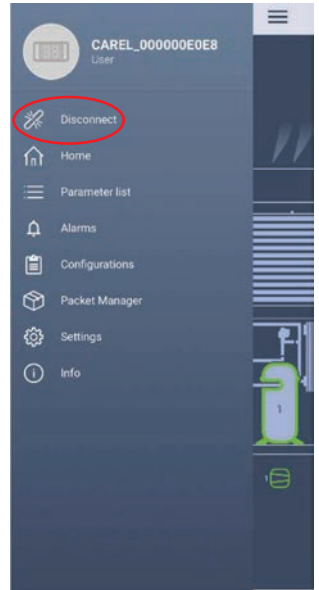
			
---	---	--	---

## ALARM CODES & TROUBLESHOOTING

Code	Description	Troubleshooting
A05	Tank water temperature probe - failure	<ul style="list-style-type: none"> <li>• Ensure tank sensor connect to terminal "1&amp;2".</li> <li>• Check tank sensor if broken (NTC thermistor: 10KΩ@25°C).</li> </ul>
A06	Outlet water temperature probe - failure	<ul style="list-style-type: none"> <li>• Check outlet water temp sensor connection. Refer to electric diagram located on the back of access door.</li> <li>• Check temp sensor if broken (NTC thermistor: 10KΩ@25°C).</li> </ul>
A13	User pump maintenance	Remind user to check component operation status. Call your installer to book maintenance. This alarm doesn't affect your heat pump operation.
A16	Ambient temperature probe - failure	<ul style="list-style-type: none"> <li>• Check ambient temp sensor connection. Refer to electric diagram located on the back of access door.</li> <li>• Check temp sensor if broken (NTC thermistor: 10KΩ@25°C).</li> </ul>
A24	Suction temperature probe - failure	<ul style="list-style-type: none"> <li>• Check suction temp sensor connection. Refer to electric diagram located on the back of access door.</li> <li>• Check temp sensor if broken (NTC thermistor: 10KΩ@25°C)</li> </ul>
A25	High pressure switch open	<ul style="list-style-type: none"> <li>• Check if stop valves open and hot water loop is filled with water. After fix the issues, switch off/on the unit to restart.</li> <li>• Check if tank sensor is installed in tank thermostat well.</li> <li>• Check if all breakers have switched on in electric enclosure.</li> <li>• Check high pressure switch connection. Refer to electric diagram located on the back of access door (marked as HP).</li> <li>• Check pressure switch if broken (NC type: normal close).</li> </ul>
A26	High pressure transducer exceeds threshold or failure	<ul style="list-style-type: none"> <li>• Check if stop valves open and hot water loop is filled with water. After fix the issues, switch off/on the unit to restart.</li> <li>• Check if tank sensor is installed in tank thermostat well.</li> <li>• Check if all breakers have switched on in electric enclosure.</li> <li>• Check high pressure transducer connection. Refer to electric diagram located on the back of access door (marked as condensing pressure).</li> <li>• Check pressure transducer if broken.</li> </ul>
A27	Low pressure transducer - failure	<ul style="list-style-type: none"> <li>• Check if fan airflow was blocked due to obstacles or dirty coil. After fix the issue, switch off/on the unit to restart.</li> <li>• Check if all breakers have switched on in electric enclosure.</li> <li>• Check if fan and electronic expansion valve work.</li> <li>• Check if refrigerant escaped and leakage spots.</li> <li>• Check low pressure transducer connection. Refer to electric diagram located on the back of access door (marked as evaporating pressure).</li> <li>• Check pressure transducer if broken.</li> </ul>
A29	Low pressure switch open	<ul style="list-style-type: none"> <li>• Check if fan airflow was blocked due to obstacles or dirty coil. After fix the issue, switch off/on the unit to restart.</li> <li>• Check if all breakers have switched on in electric enclosure.</li> <li>• Check if fan and electronic expansion valve work.</li> <li>• Check if refrigerant escaped and leakage spots.</li> <li>• Check low pressure switch connection. Refer to electric diagram located on the back of access door (marked as LP).</li> <li>• Check pressure switch if broken (NC type: normal close when refrigerant exists in the system).</li> </ul>
A30	Reversed phase of power supply or compressor overload	<ul style="list-style-type: none"> <li>• Check 3 phase order from isolating switch to heat pump</li> <li>• Check current setting on compressor overload. Refer to electric diagram located on the back of access door.</li> <li>• Check 3 phase fail relay if broken.</li> <li>• Check compressor overload if broken.</li> </ul>
A32	Compressor maintenance	Remind user to check component operation status. Call your installer to book maintenance. This alarm doesn't affect your heat pump operation.
A34	Fan maintenance	Remind user to check component operation status. Call your installer to book maintenance. This alarm doesn't affect your heat pump operation.

# COMMISSIONING LOG & CHECKLIST



The checklist is **ONLY** to be completed by an Authorised person.



To complete this section you will need to log onto the Applica App. Please refer to the section “Applica App” on page 28 for instructions.

Date of Commissioning: \_\_\_ / \_\_\_ / \_\_\_ Installed By: \_\_\_\_\_ Unit Serial No: \_\_\_\_\_

Check Item	✓	What can happen if not checked
Is the unit installed securely?		Falling, vibration, noise
Has an inspection been made to check for leakage of hot water loop?		Water leakage
Has all thermal insulation been completed for water pipes?		Heat loss, water freezing
Are the electric wires installed securely?		Operation failure, no hot water
Is the wiring in accordance with the specifications?		Operation failure, electrical fire
Are the stop valves open in hot water loop?		No hot water
Is the tank water becoming warmer when the heat pump is operating?		No hot water
In temperature	°C	Check after compressor operating 1 hour
Out temperature	°C	Check after compressor operating 1 hour
Fan speed	%	Check after compressor operating 1 hour
EXV opening	%	Check after compressor operating 1 hour
HP saturated temperature	°C	Check after compressor operating 1 hour
LP saturated temperature	°C	Check after compressor operating 1 hour
Suction temperature	°C	Check after compressor operating 1 hour
Is the end user fully aware of the operating procedure?		Incorrect operation

If you have answered **NO** to any of the above, you must check and correct before appliance hand-over to customer.

Check water in/out temperature, fan speed, EXV opening.

Check HP, LP, suction temperature.

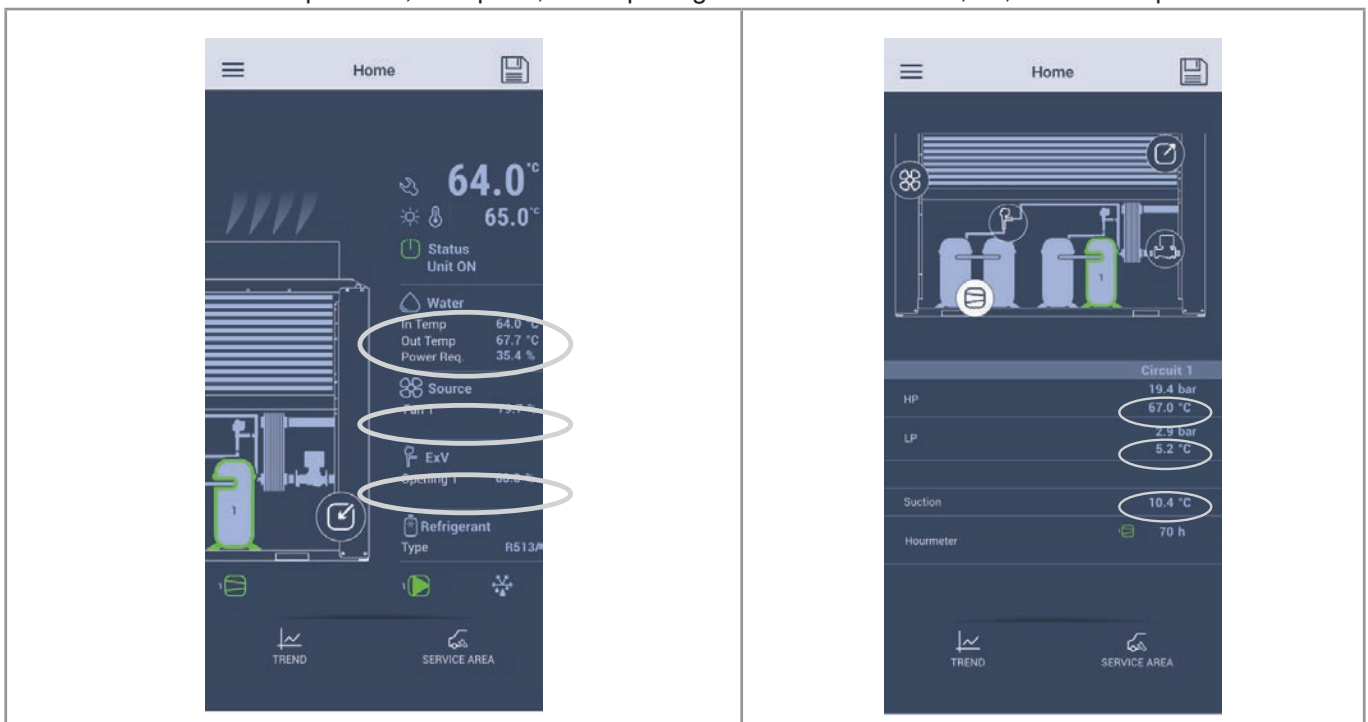



## BMS SETTING

The heat pump controller provides a database of supervisor variables via Modbus RTU protocol over RS485. Use a specific cable for RS485 (AWG20- 22 with 1½ twisted pair plus shield) to connect to the terminals marked “A”(“+”), “B” (“-”) and “GND” in the electrical enclosure shown below.

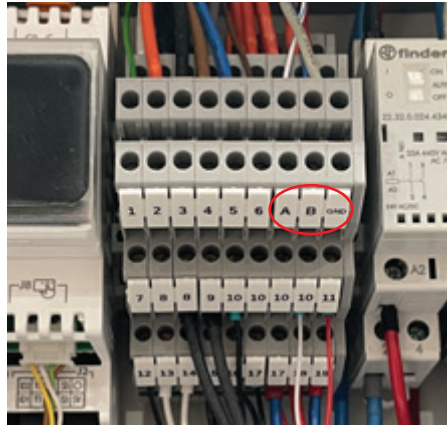

When using Modbus RTU protocol you need to set BMS port as following:

Code	Description	Default
Hd00	BMS serial address; You need set different address for each unit	1
Hd01	BMS baud rate: 3=9600; 4=19200; 5=38400; 6=57600; 7=115200	7
Hd02	BMS settings: 0= 8-NONE-1; 1= 8-NONE-2; 2= 8-EVEN-1; 3= 8-EVEN-2; 4= 8-ODD-1; 5= 8-ODD-2	1
Hd07	BMS: supervisor database 0= 32bit; 1= 16bit	0

Change above parameters through the user terminal. Please refer to the section “User Terminal” on page 27“ for user terminal introduction.

## MENU STEPS



1. Go to the standard display.



2. Press PRG (⊙): the password prompt (PSd) is shown  
User service password: **2000**

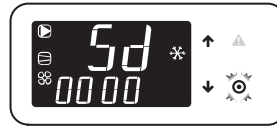

3. Press PRG: the first digit of the password flashes; set the value, press PRG. The second digit now flashes; enter the other digits to complete the password



4. Press PRG: if the password is correct, the first parameter category is shown: PLt



5. Press the up arrow. ESC will show.



6. Press PRG to escape back to the standard display



7. Press the down arrow till Hd00. Press PRG: the value flashes; press UP/DOWN to change the value. Press PRG to confirm  
**Hd00 – BMS: Serial Address**



8. Press the down arrow till Hd01. Press PRG: the value flashes; press UP/DOWN to change the value. Press PRG to confirm  
**Hd01 – BMS: Baud rate**



9. Press the down arrow till Hd02. Press PRG: the value flashes; press UP/DOWN to change the value. Press PRG to confirm. Hold PRG for 3 seconds and release to go back to the main display  
**Hd02 – BMS: Settings**

## REGISTRY INFORMATION

When setting up your control monitoring interface, it is necessary to know the registry information to select the data you wish to monitor.



**All parameters are READ-ONLY.**

Refer to the tables below for registers and data points.

Input Register Information				
Register Address	Description	Bit	Type	Unit
0	User pump working hours	32	INT	h
2	Compressor working hours	32	INT	h
14	Suction temp	32	REAL	°C
20	Discharge pressure probe	32	REAL	bar
22	Suction pressure probe	32	REAL	bar
24	Cond. temp. probe (or press. probe converted value)	32	REAL	°C
26	Evap. temp. probe (or press. probe converted value)	32	REAL	°C
40	Source fan working hours	32	INT	h
50	EEV position	16	REAL	%
54	Tank water temp	32	REAL	°C
56	Outlet water temp	32	REAL	°C
65	Source fan - Inverter request	32	REAL	%
71	Unit status (1=OFF by keyboard, 5=OFF by alarm, 6=Unit in defrosting, 7=Unit ON)	16	INT	-
92	Power request (compressor will be running at 100%)	32	REAL	%

Input Status Information				
Register Address	Description	Bit	Type	Unit
4	Alarm 05: Tank water temperature probe - failure	16	BOOL	-
5	Alarm 06: Outlet water temperature probe - failure	16	BOOL	-
12	Alarm 13: User pump maintenance	16	BOOL	-
15	Alarm 16: Ambient temperature probe - failure	16	BOOL	-
23	Alarm 24: Suction temperature probe - failure	16	BOOL	-
24	Alarm 25: High pressure switch open	16	BOOL	-
25	Alarm 26: High pressure transducer exceeds threshold or failure	16	BOOL	-
26	Alarm 27: Low pressure transducer - failure	16	BOOL	-
27	Alarm 29: Low pressure switch open	16	BOOL	-
29	Alarm 30: Reversed phase of power supply or compressor overload	16	BOOL	-
31	Alarm 32: Compressor maintenance	16	BOOL	-
33	Alarm 34: Fan maintenance	16	BOOL	-

# Rinnai Australia Pty Ltd

ABN 74 005 138 769 | AU45204

100 Atlantic Drive, Keysborough, Victoria 3173  
P.O. Box 460, Braeside, Victoria 3195  
Tel: (03) 9271 6625  
Fax: (03) 9271 6622

## **National Help Line**

Tel: 1300 555 545\* Fax: 1300 555 655  
*Monday to Friday, 8.00 am to 5.00 pm EST.*

## **After Hours Hot Water Service Line**

Tel: 1800 000 340\*

*\*Cost of a local call may be higher from a mobile phone.  
(National calls from public phones in Australia are free.)*

For further information visit **[www.rinnai.com.au](http://www.rinnai.com.au)**  
or email **[enquiry@rinnai.com.au](mailto:enquiry@rinnai.com.au)**

Rinnai has a Service and Spare Parts network with personnel who are fully trained and equipped to give the best service on your Rinnai appliance. If your appliance requires service, please call our National Help Line. Rinnai recommends that this appliance be serviced every 3 years.

With our policy of continuous improvement, we reserve the right to change, or discontinue at any time, specifications or designs without notice.