

Commercial Heat Pump

Specification Guide



Rinnai

Rinnai

Class leading efficiency

Backed with 45+ Years of experience in building quality refrigeration systems, Rinnai's Commercial Hot Water Heat Pump boasts a range of class leading attributes. High efficiency performance, revolutionary environmentally friendly R513A refrigerant, multiple flexible installation options and a wide operating envelope to suit the harsh Australian climate.



Features

- Heavy duty galvanized steel construction
- Designed with 45+ Years of APAC refrigerated experience
- Wide ambient temperature operating range
- Zero Ozone Depletion Potential (ODP) R513A refrigerant
- 56% lower Global Warming Potential (GWP) than R134A
- Class leading Coefficient of Performance (COP)
- Integrated primary circulation pump
- Easy commissioning/diagnostics via smart phone app
- Multiple installation configuration options.
- Optional back-up electric heating function for low ambient boost
- Corrosion resistant Epoxy coated coils as standard
- Custom options available:
 - Full 316 stainless steel cabinets
 - High static fans for plant room applications
 - Blygold treated coils for extra corrosion protection
 - Circulation pump deletion option for retrofits
 - Ducted version for internal installation

CHP020VP

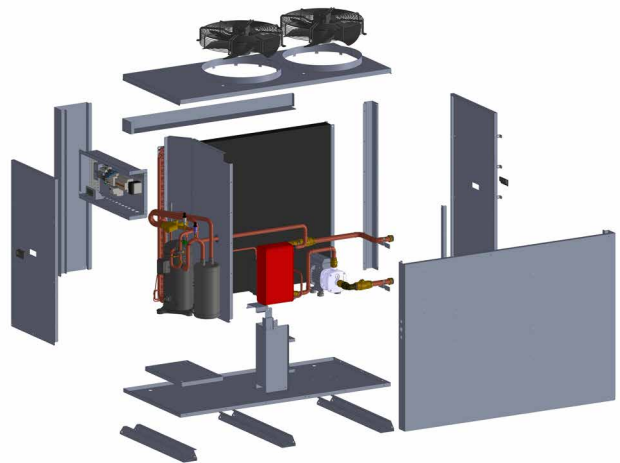
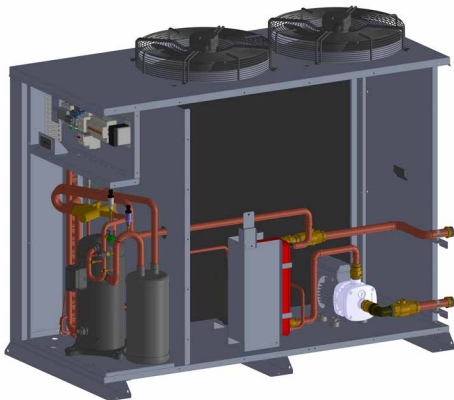

CHP040VP

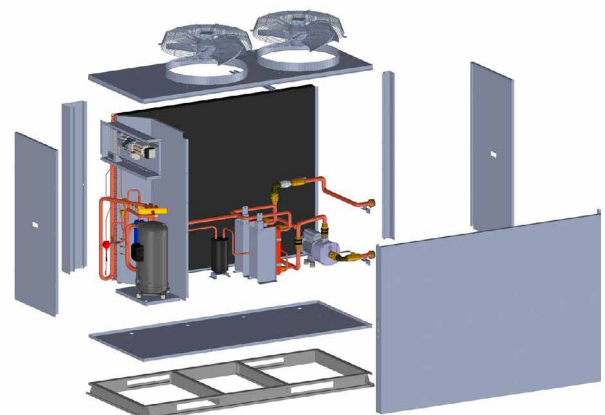
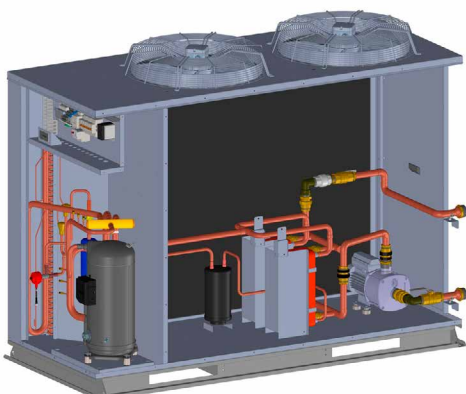

CHP020 Performance Data

Recovery Rate Data

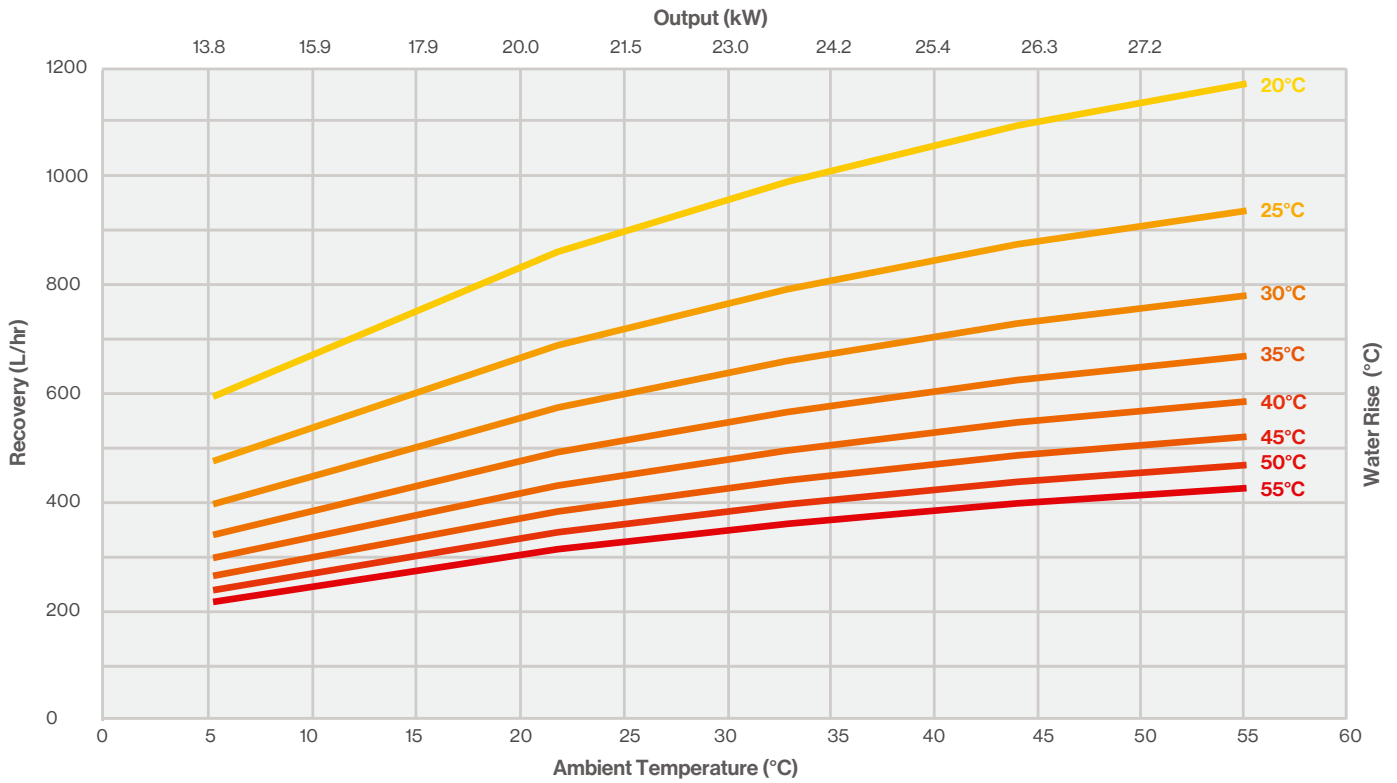

Recovery Litres p/h	Amb Temp (C)	5	10	15	20	25	30	35	40	45	50
	Output (kW)	13.8	15.9	17.9	20.0	21.5	23.0	24.2	25.4	26.3	27.2
Water Rise (C)	20	594	683	772	861	926	990	1042	1094	1133	1171
	25	476	547	618	689	741	792	834	875	906	937
	30	396	456	515	574	617	660	695	729	755	781
	35	340	390	441	492	529	566	595	625	647	669
	40	297	342	386	431	463	495	521	547	566	586
	45	264	304	343	383	411	440	463	486	503	521
	50	238	273	309	344	370	396	417	438	453	469
	55	216	248	281	313	337	360	379	398	412	426

COP & Capacity Data

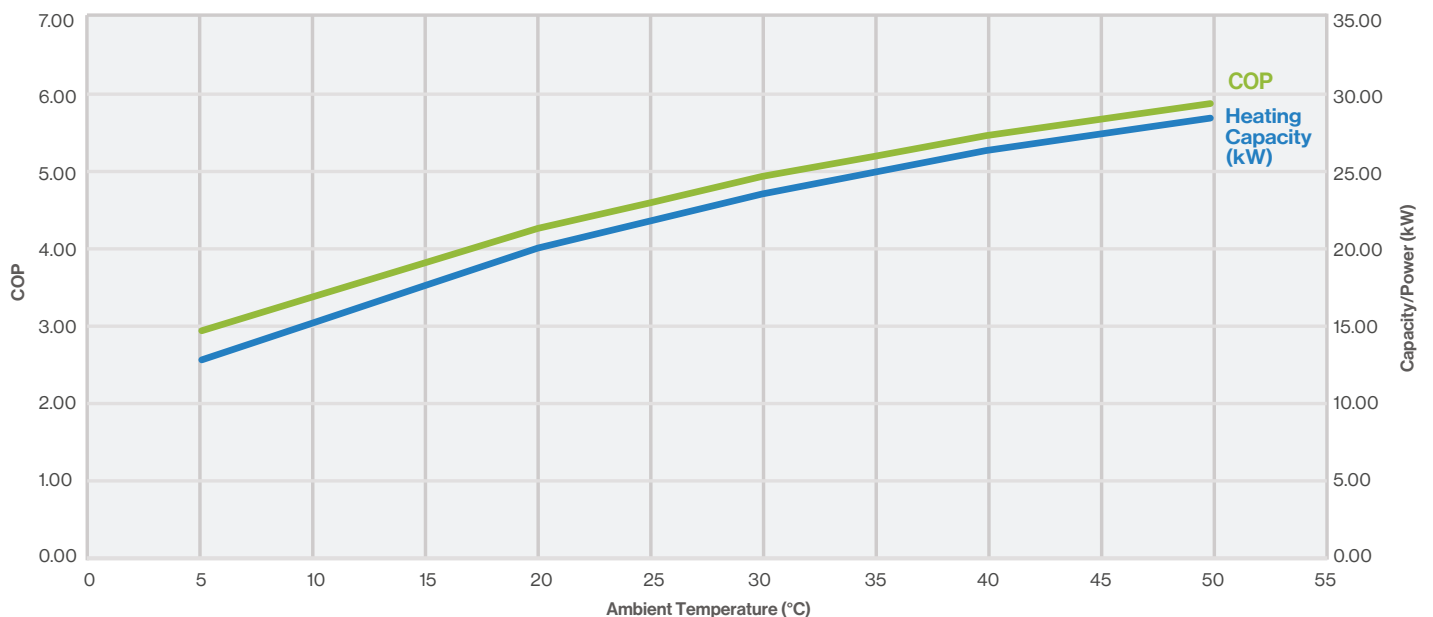

	Amb Temp (C)	5	10	15	20	25	30	35	40	45	50
Capacity	kW	13.8	15.9	17.9	20.0	21.5	23.0	24.2	25.4	26.3	27.2
Power	kW	4.7	4.7	4.7	4.7	4.7	4.7	4.7	4.6	4.6	4.6
COP		2.95	3.39	3.83	4.27	4.60	4.95	5.20	5.47	5.68	5.89

CHP040 Performance Data

Recovery Rate Data

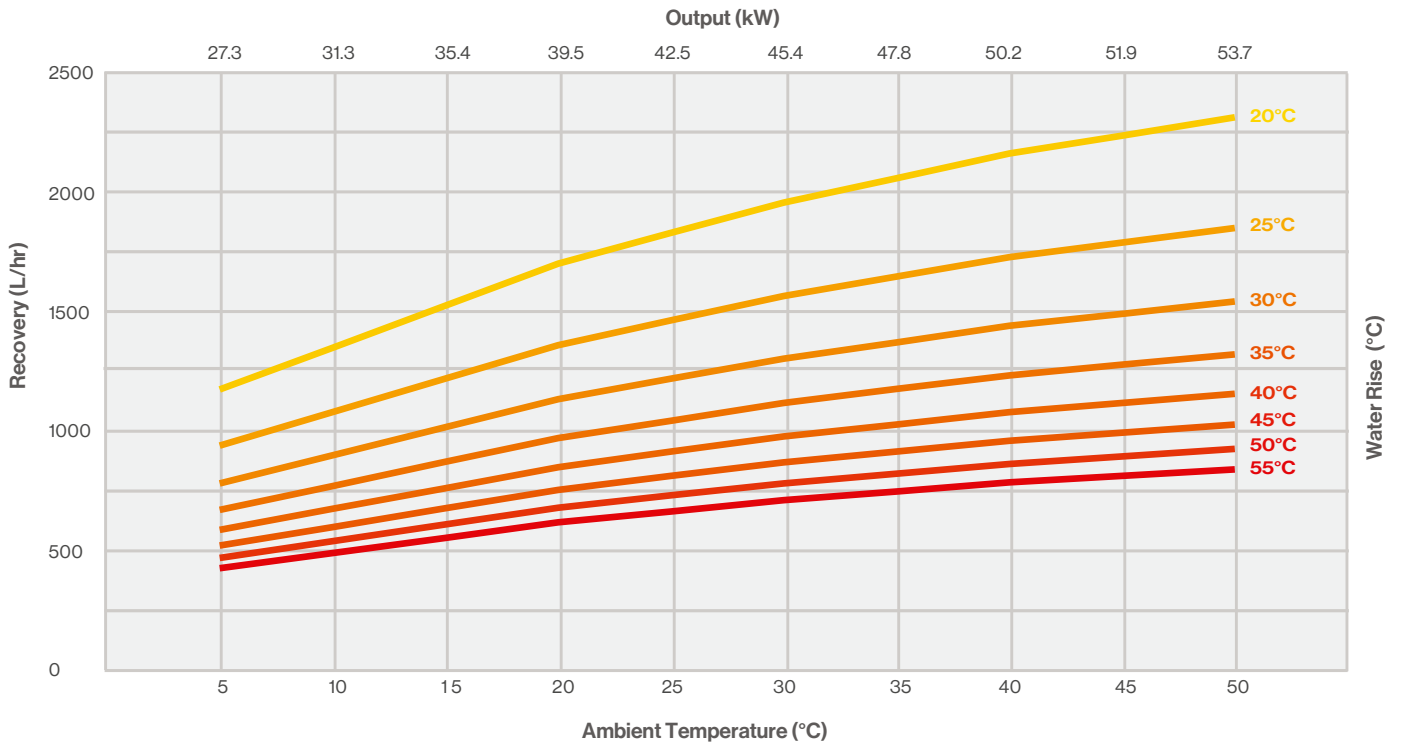

		Ambient Temperature (°C)										
Recovery Litres p/h	Amb Temp (C)	5	10	15	20	25	30	35	40	45	50	
	Output (kW)	27.3	31.3	35.4	39.5	42.5	45.4	47.8	50.2	51.9	53.7	
Water Rise (C)	20	1174	1350	1525	1701	1829	1956	2058	2160	2237	2313	
	25	939	1080	1220	1361	1463	1565	1647	1728	1789	1851	
	30	783	900	1017	1134	1219	1304	1372	1440	1491	1542	
	35	671	771	872	972	1045	1118	1176	1234	1278	1322	
	40	587	675	763	850	914	978	1029	1080	1118	1157	
	45	522	600	678	756	813	869	915	960	994	1028	
	50	470	540	610	680	731	782	823	864	895	925	
	55	427	491	555	619	665	711	748	786	813	841	

COP & Capacity Data

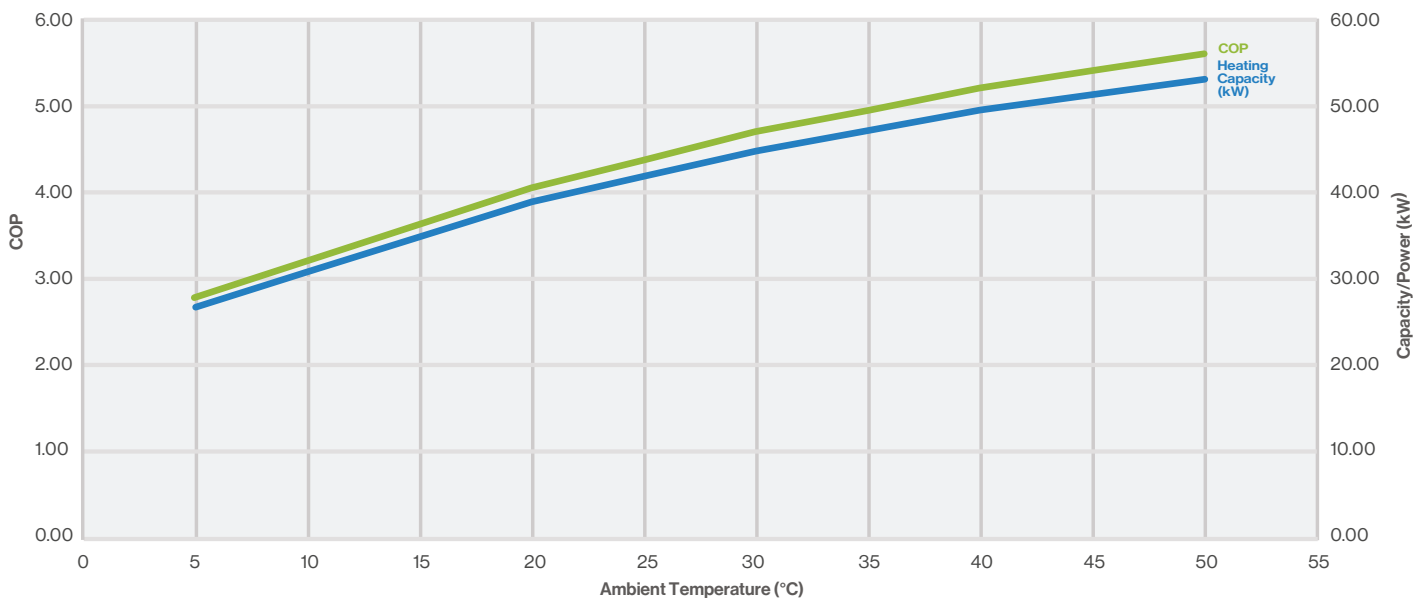

	Amb Temp (C)	5	10	15	20	25	30	35	40	45	50
Capacity	kW	27.3	31.3	35.4	39.5	42.5	45.4	47.8	50.2	51.9	53.7
Power	kW	9.6	9.6	9.6	9.6	9.6	9.6	9.6	9.5	9.5	9.5
COP	-	2.83	3.25	3.68	4.10	4.42	4.75	5.00	5.25	5.45	5.65

Dimensions & Clearances

Description		Product Dimension (mm)						
Model	Version	A	B	C	D	E	F	G
CHP020	Top Discharge	1162	730	1550	1288	809	1590	-
	Side Discharge	1162	730	1550	-	809	1590	895
CHP040	Top Discharge	1442	850	2050	1565	928	2100	-
	Side Discharge	1442	850	2050	-	928	2100	1011

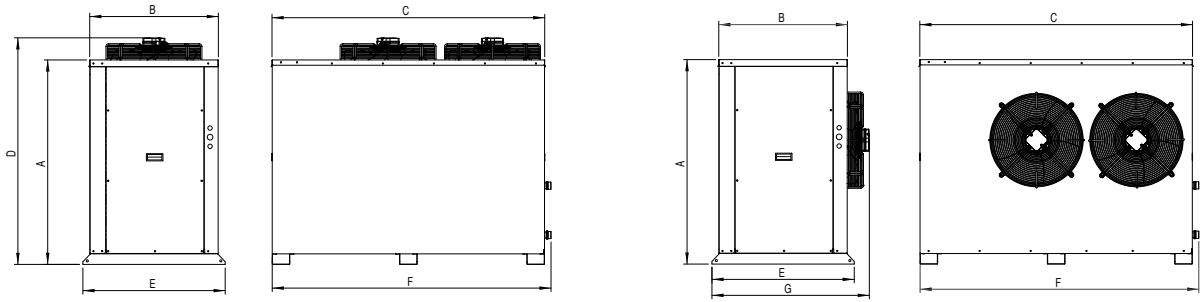

Top Discharge Unit

Side Discharge Unit

Description		Clearance Dimension (mm)					
Model	Version	A	B	C	D	E	F
CHP020	Top Discharge	850	500	1000	500	1500	-
	Side Discharge	850	500	1000	500	-	1500
CHP040	Top Discharge	850	650	1000	600	1800	-
	Side Discharge	850	650	1000	600	-	1800

Top Discharge Unit (plan view)

Top Discharge Unit (side view)

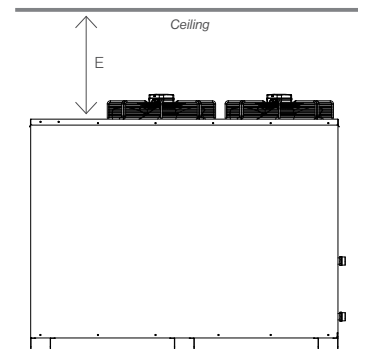
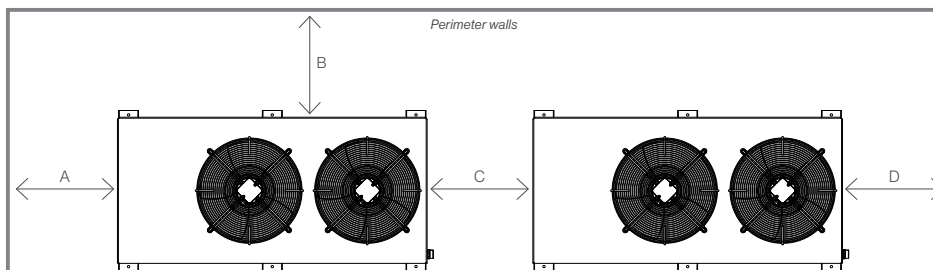

Side Discharge Unit (plan view)

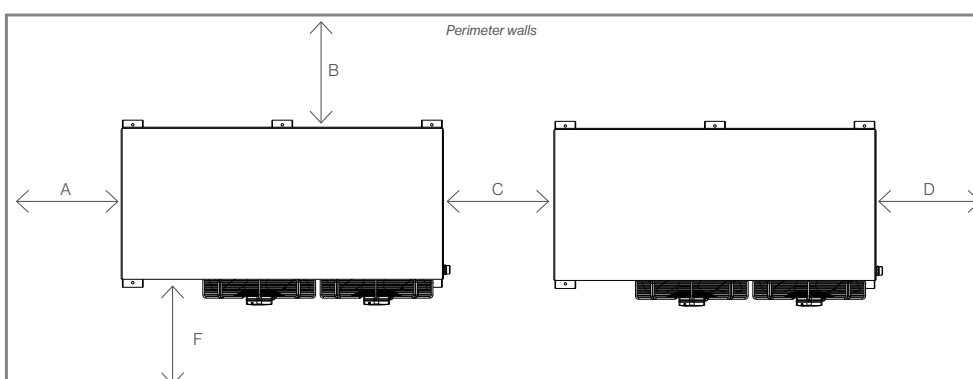

Typical Installations

Commercial Heat Pump Install with Storage & Re-circulation

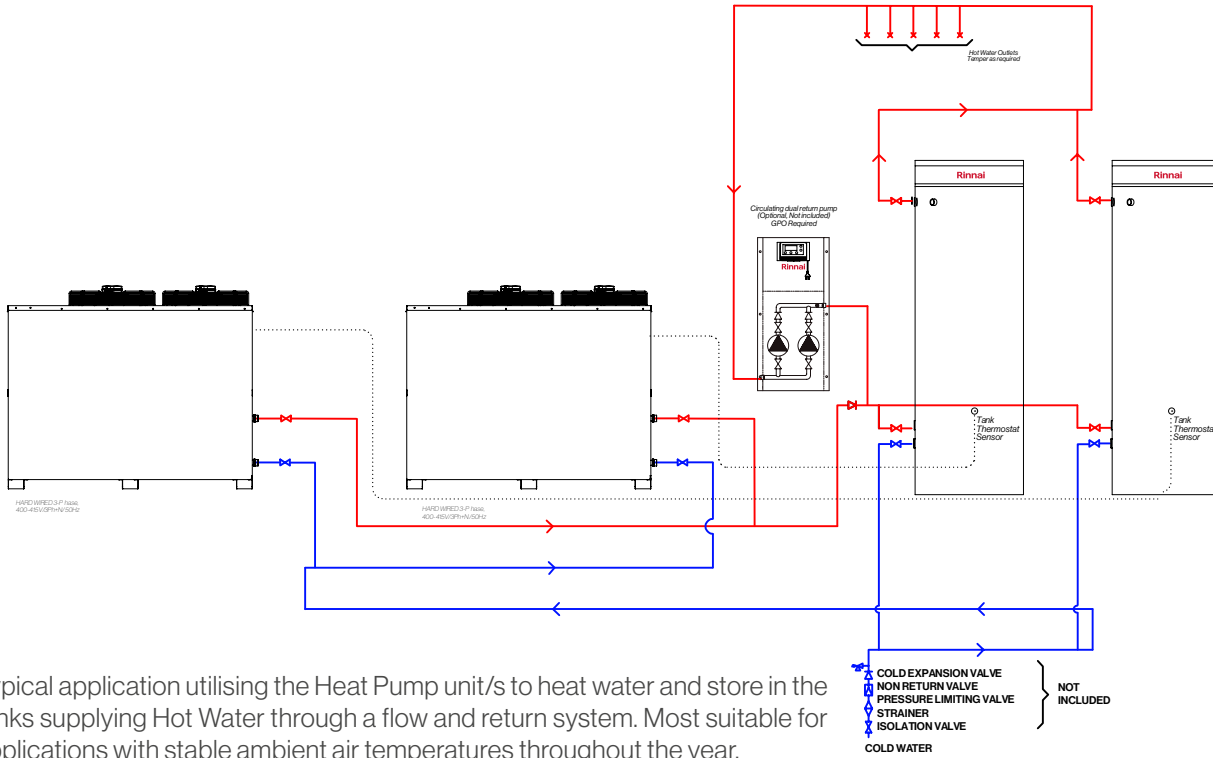

Typical application utilising the Heat Pump unit/s to heat water and store in the tanks supplying Hot Water through a flow and return system. Most suitable for applications with stable ambient air temperatures throughout the year.

Storage Tank/s maybe installed with the auxiliary boost elements as an option in low ambient applications, or as a backup in the event of a fault.

Commercial Heat Pump Install with Storage, Inline boost & Re-circulation

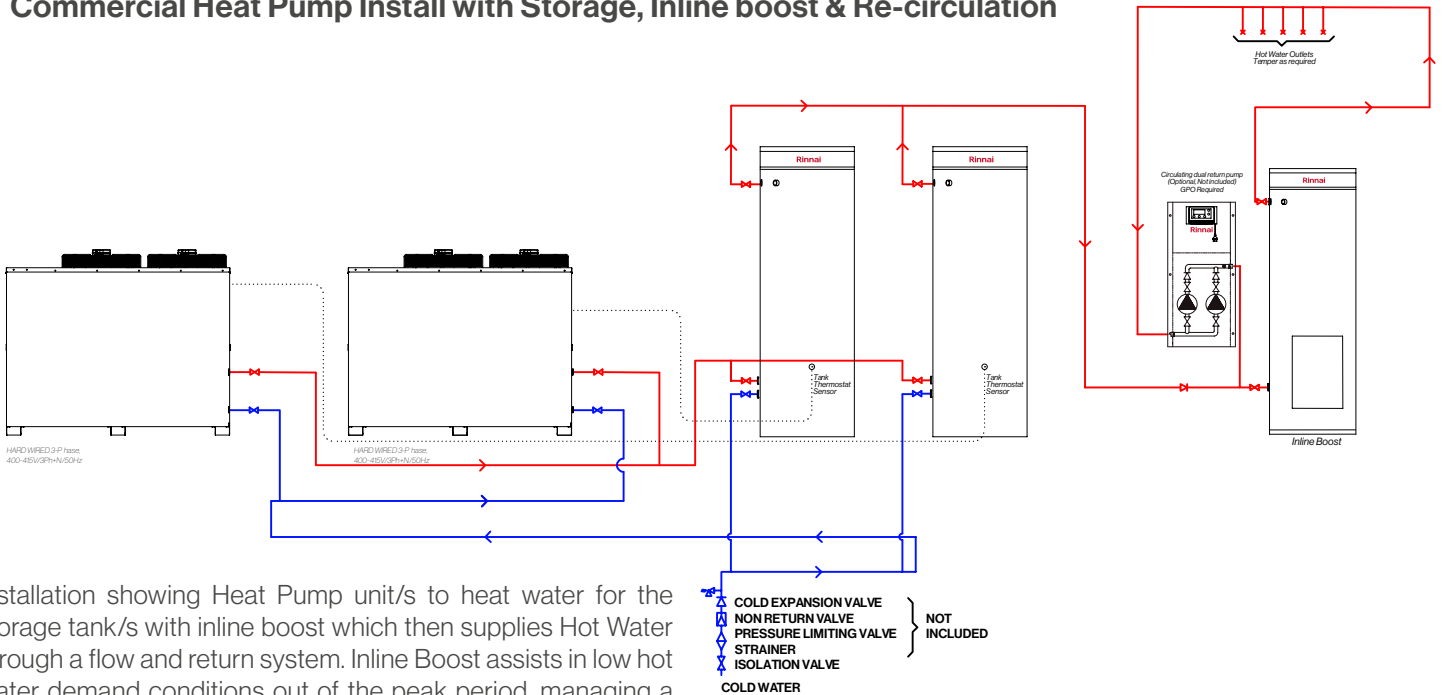

Installation showing Heat Pump unit/s to heat water for the storage tank/s with inline boost which then supplies Hot Water through a flow and return system. Inline Boost assists in low hot water demand conditions out of the peak period, managing a more stable hot water delivery throughout the varying ambient conditions. The inline boost tank/s also ensures flow and return loop is kept at the specified temperature.

Storage Tank/s maybe installed with the auxiliary boost elements as an option in low ambient applications, or as a backup in the event of a fault.

Specifications

Specification		Units	CHP020	CHP040
Heating Capacity ^[1]		kW	20.0	39.5
Electrical Supply		V/Ph/Hz	400 - 415/3/50	400 - 415/3/50
Power Input ^[2]		kW	4.7	9.6
COP ^{[1][2]}		-	4.27	4.10
Recovery Rate ^[1]		L/Hr	344	680
Operating Range (Ambient) ^[1]		°C	0 - 50	0 - 50
Compressor		-	Scroll	Scroll
Compressor Quantity		-	1	1
No. of Refrigeration Circuits		-	1	1
Refrigerant		Type	R513A	R513A
Outdoor Fans		Type	Hybrid Axial	Hybrid Axial
Outdoor Fan Quantity		-	2	2
Outdoor Fan Speed Control		Type	Variable	Variable
Outdoor Coil		Type	Cu/Al	Cu/Al
Outdoor Coil Fin treatment		Type	Black Epoxy	Black Epoxy
Outdoor Airflow		L/s	2500	4470
Water/Refrigerant Heat Exchanger		Type	Double Wall Stainless Steel	Double Wall Stainless Steel
Water/Refrigerant Heat Exchanger Quantity		-	1	2
Rated Sound Power Level		dB(A)	66.6 @ 1m	68.7 @ 1m
Rated Sound Pressure Level		dB(A)	53 @ 3m	55 @ 3m
Cabinet IP Rating		-	IPX4	IPX4
Water Pump		Model	Grundfos CM 3-2	Grundfos CM 10-1
Water Pump Electrical Supply		V/Ph/Hz	240/1/50	240/1/50
Outlet Water Head		m	10	8
Water Connections		MBSP	32	50
Rated Water Pressure		kPa	1000	100
Maximum Supply Water Pressure		kPa	800	800
Pressure Limits - ECV Fitted	Fit PLV if mains pressure exceeds	kPa	680	680
	Recommended PLV Pressure Rating		500	500
Pressure Limits - ECV Not Fitted	Fit PLV if mains pressure exceeds	kPa	800	800
	Recommended PLV Pressure Rating		500	500
Maximum Water Temperature Setting		°C	65	65
Dimensions	Height	mm	1162	1442
	Width	mm	730	850
	Length	mm	1550	2050
Nominal Weight ^[3]		kg	236	360

With our policy of continuous improvement, we reserve the right to change, or discontinue at anytime, specifications or designs without notice. Note: All images contained within this brochure are for illustrative purposes only, the colours and finishes of the products featured are as close to the respective product range as photographic lighting and printing processes allow. The heat pump must be installed in a freely ventilated space in accordance with the nominated installation clearances. Insufficient ventilation may impede product performance and efficiency.

^[1] Test condition: 20°C ambient / 60%RH. 39°C water in / 45°C water out.

^[2] Water pump power is not included.

^[3] For base model only. Factory options will vary.



Rinnai Australia Pty Ltd

ABN 74 005 138 769

100 Atlantic Drive,
Keysborough, Victoria 3173

For further information
call 1300 555 545 or visit
rinnai.com.au

TOTAL HOME COMFORT



HOT WATER



HEATING



COOLING

Rinnai