

# 18. EXPLODED DIAGRAMS AM SERIES



Some part details may have changed since publication of this manual.

**Contact Rinnai to confirm spare parts details before ordering.**

REU-AM2626WD-AK SERIES  
EXPLODED VIEW-CABINET(OUTDOOR)  
ILLUSTRATION REPRESENTS 2626 MODEL

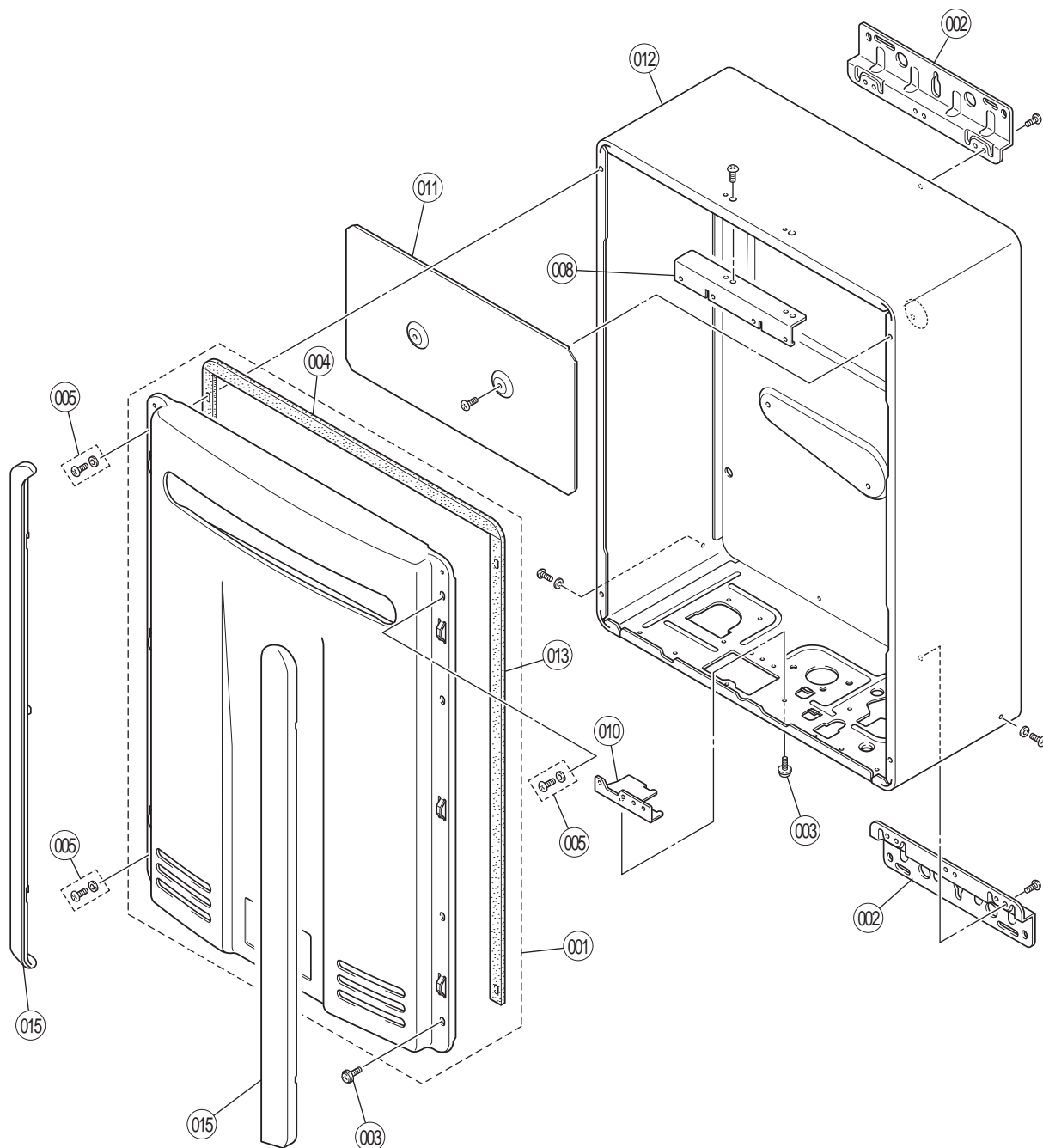



Some part details may have changed since publication of this manual.

**Contact Rinnai to confirm spare parts details before ordering.**

REU-AM2626WD-AK SERIES  
EXPLODED VIEW-INTERNAL(OUDOOR)  
COMBUSTION(2626 MODEL ONLY)

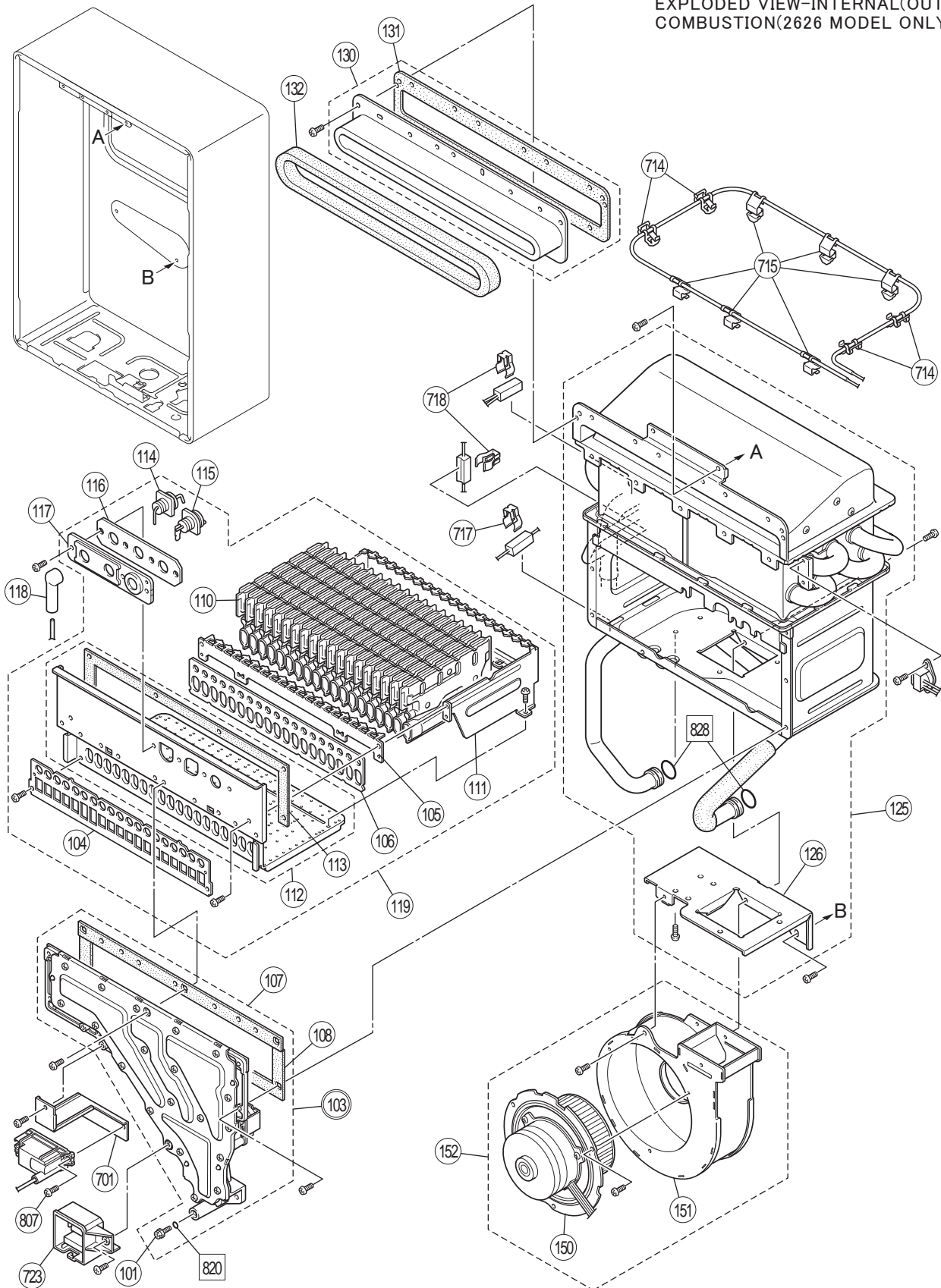



Some part details may have changed since publication of this manual.

**Contact Rinnai to confirm spare parts details before ordering.**

REU-AM2626WD-AK SERIES  
EXPLODED VIEW-INTERNAL(OUDOOR)  
COMBUSTION(2024 MODEL ONLY)

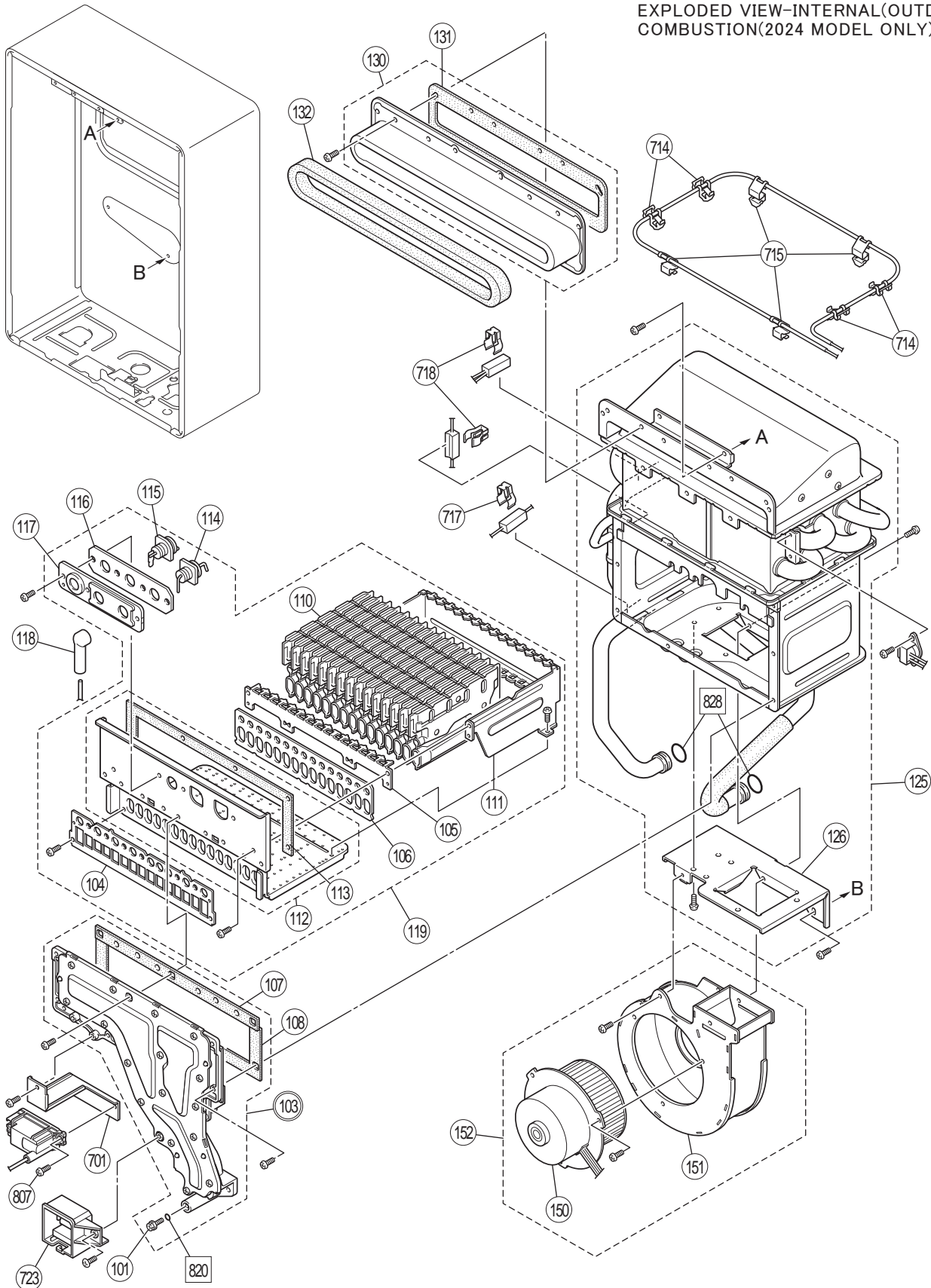



Some part details may have changed since publication of this manual.

**Contact Rinnai to confirm spare parts details before ordering.**

REU-AM2626WD-AK SERIES  
EXPLODED VIEW-INTERNAL(OUDOOR)  
COMBUSTION(1620,1220 MODEL ONLY)

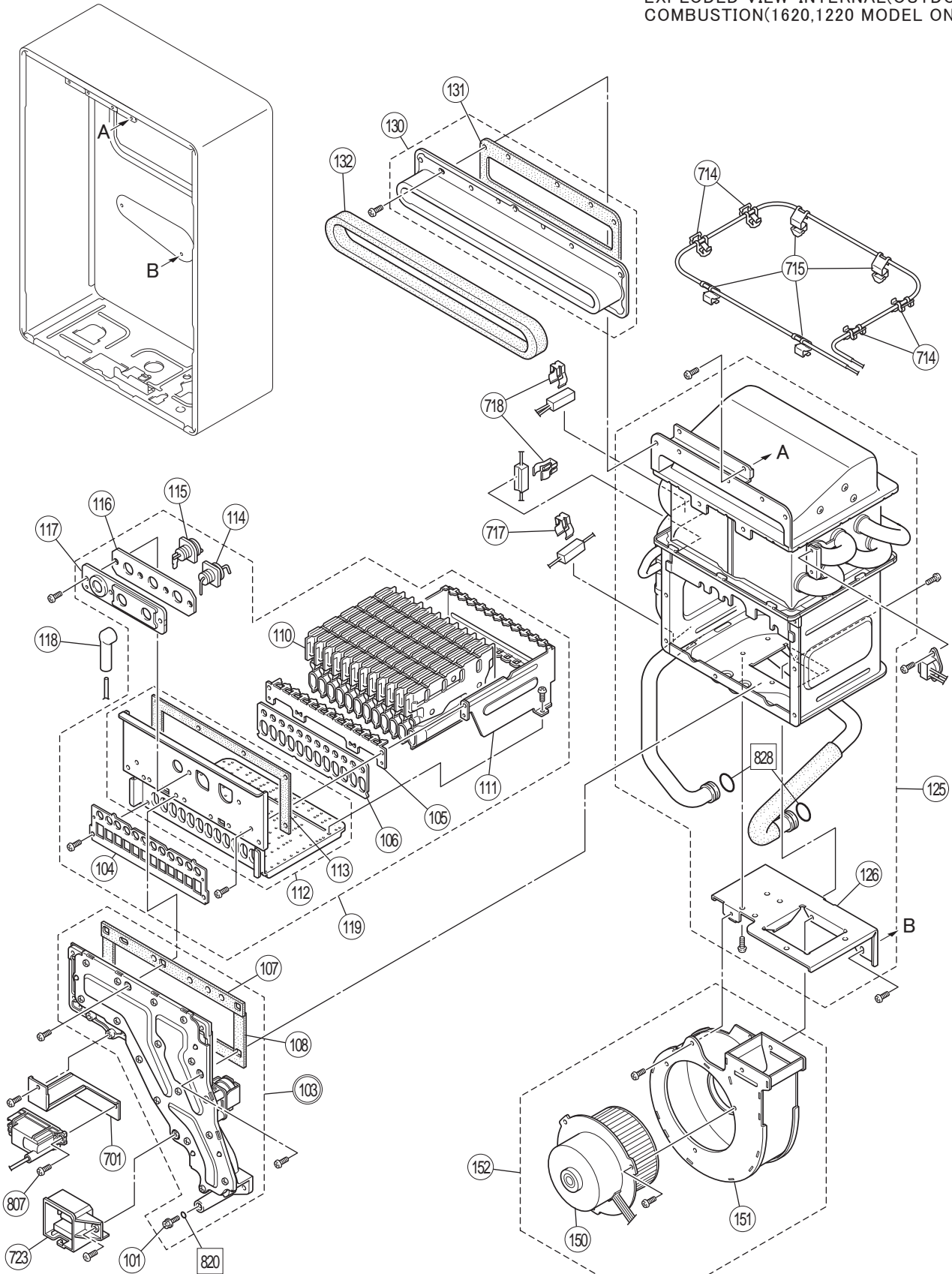



Some part details may have changed since publication of this manual.

**Contact Rinnai to confirm spare parts details before ordering.**

REU-AM2626WD-AK SERIES  
EXPLODED VIEW-INTERNAL(OUTDOOR)  
ILLUSTRATION REPRESENTS 2626 MODEL

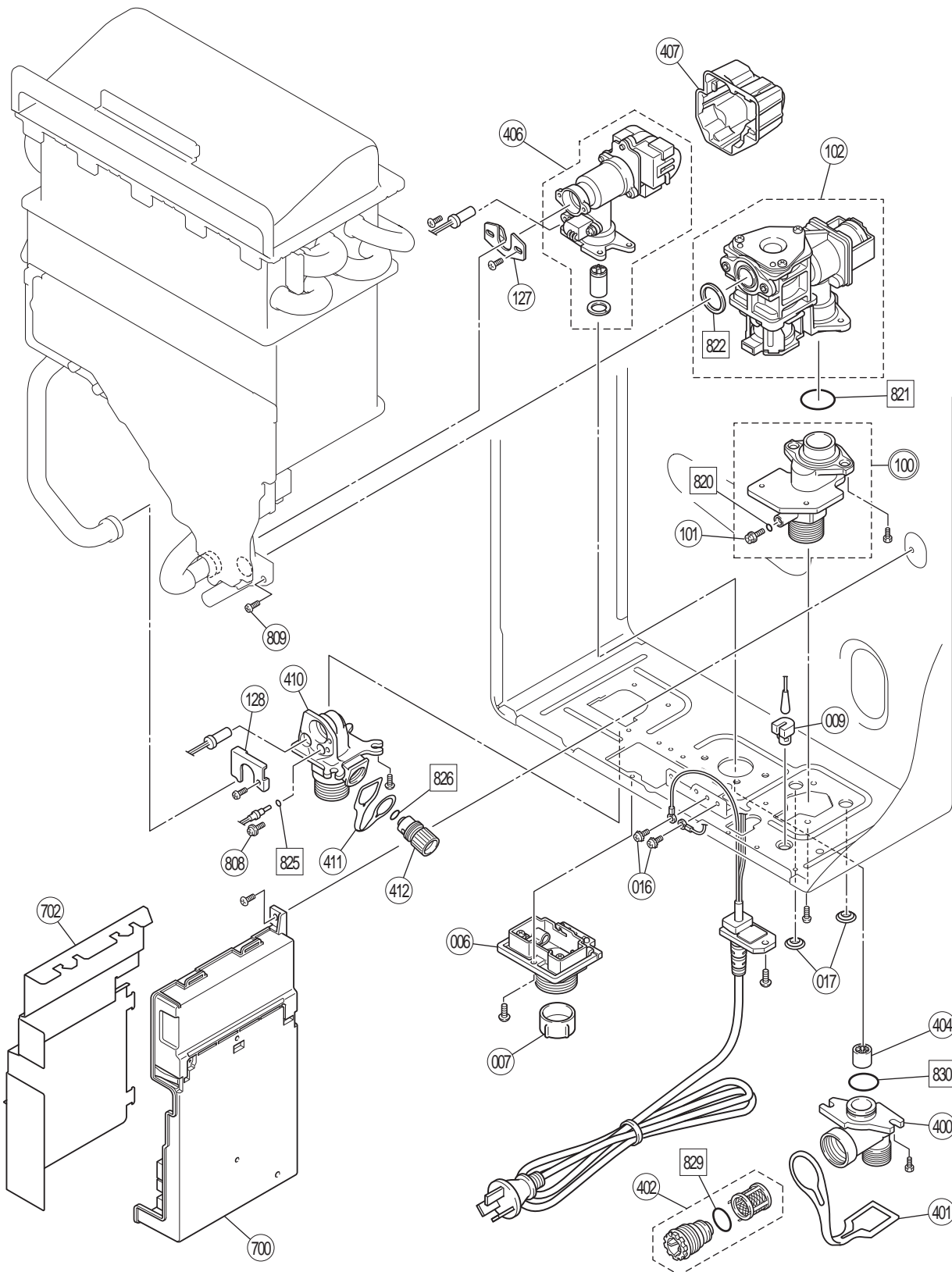



Some part details may have changed since publication of this manual.

**Contact Rinnai to confirm spare parts details before ordering.**

REU-AM2626WD-AK SERIES  
EXPLODED VIEW-ELECTRICAL(OUTDOOR)  
ILLUSTRATION REPRESENTS 2626 MODEL

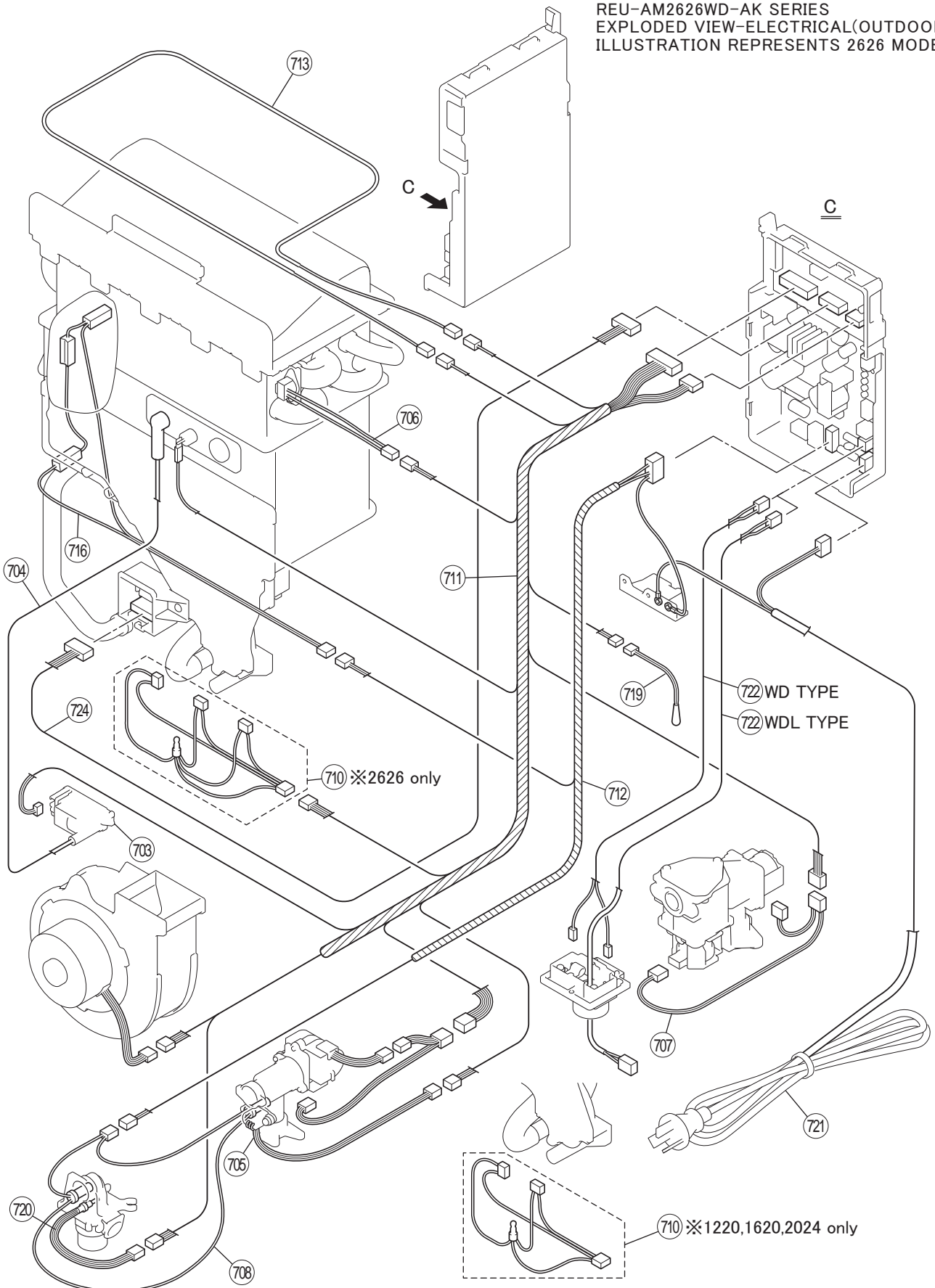

# 19. PART LIST AM SERIES



Some part details may have changed since publication of this manual.

**Contact Rinnai to confirm spare parts details before ordering.**

2017 / 2018 AM SERIES

Effective: 23/01/18 Issue 01

NO	Part Name	RA Part No.	Parts Code	REU-AM2626WD-AK	REU-AM2626WD-50-AK	REU-AM2626WDL-AK	REU-AM2626WDL-50-AK	REU-AM2024WD-AK	REU-AM2024WD-50-AK	REU-AM1620WD-AK	REU-AM1620WD-50-AK	REU-AM1220WD-AK	REU-AM1220WD-50-AK
001	PANEL FRONT AM2626WD	92099756	019-5431000	1									
001	PANEL FRONT 50C AM2626WD	92099762	019-5432000		1								
001	PANEL FRONT AM2626WDL	92099772	019-5433000			1							
001	PANEL FRONT 50C AM2626WDL	92099768	019-5434000				1						
001	PANEL FRONT AM2024WD	92099780	019-5435000					1					
001	PANEL FRONT 50C AM2024WD	92099776	019-5436000						1				
001	PANEL FRONT AM1620WD	92099770	019-5437000							1			
001	PANEL FRONT 50C AM1620WD	92099758	019-5438000								1		
001	PANEL FRONT AM1220WD	92099766	019-5439000									1	
001	PANEL FRONT 50C AM1220WD	92099782	019-5440000										1
002	BRKT WALL KM3237WDC	92099429	106-700-000	2	2	2	2	2	2	2	2	2	2
003	EARTH SCREW		501-889-000	1	1	1	1	1	1	1	1	1	1
004	FRONT PANEL PACKING		580-0391000	1	1	1	1	1	1	1	1	1	1
005	TRUSS SCREW		501-856-010	3	3	3	3	3	3	3	3	3	3
006	HARNESS EASY CONN V1620WG/ WB	92099955	106-651-000	1	1	1	1	1	1	1	1	1	1
007	CABLE SEAL PACKING		580-306-000	1	1	1	1	1	1	1	1	1	1
008	REINFORCEMENT PLATE		044-271-000	1	1	1	1	1	1	1	1	1	1
009	TH PACKING		580-0902000	1	1	1	1	1	1	1	1	1	1
010	CABLE BRACKET		537-1399000	1	1	1	1	1	1	1	1	1	1
011	HEAT SHIELD PLATE		030-0405000	1	1	1	1	1	1	1	1	1	1
013	MAIN BODY PACKING SIDE		580-0392000	2	2	2	2	2	2	2	2	2	2
015	BRACE FRONT PANEL AM SERIES	92099774	019-5430000	2	2	2	2	2	2	2	2	2	2
016	SCREW		501-0462000	1	1	1	1	1	1	1	1	1	1



Some part details may have changed since publication of this manual.

**Contact Rinnai to confirm spare parts details before ordering.**

2017 / 2018 AM SERIES

Effective: 23/01/18 Issue 01

NO	Part Name	RA Part No.	Parts Code	REU-AM2626WD-AK	REU-AM2626WD-50-AK	REU-AM2626WDL-AK	REU-AM2626WDL-50-AK	REU-AM2024WD-AK	REU-AM2024WD-50-AK	REU-AM1620WD-AK	REU-AM1620WD-50-AK	REU-AM1220WD-AK	REU-AM1220WD-50-AK
017	SEAL PACKING (GRAY)		510-893-000	2	2	2	2	2	2	2	2	2	2
100	INLET GAS 3/4 A SERIES	92099648	106-764-000	1	1	1	1	1	1	1	1	1	1
101	SCREW TEST POINT	90195157	501-275-005	1	1	1	1	1	1	1	1	1	1
102	GAS CONTROL A SERIES	92099650	120-0303000	1	1	1	1	1	1	1	1	1	1
103	MANIFOLD LP A2626 A2426	92099652	101-875-000	1	1	1	1						
103	MANIFOLD NG A2626 A2426	92099654	101-876-000	1	1	1	1						
103	MANIFOLD LP A2024	92099656	101-877-000					1	1				
103	MANIFOLD NG A2024	92099658	101-878-000					1	1				
103	MANIFOLD LP A1620	92099660	101-879-000							1	1	1	1
103	MANIFOLD NG A1620	92099662	101-880-000							1	1	1	1
104	DAMPER		140-866-000	1	1	1	1						
104	DAMPER		140-865-000					1	1				
104	DAMPER		140-864-000							1	1	1	1
105	BURNER SUPPORT FRONT		538-6957000	1	1	1	1						
105	BURNER SUPPORT FRONT		538-6953000					1	1				
105	BURNER SUPPORT FRONT		538-6952000							1	1	1	1
106	GASKET		580-1014000	1	1	1	1						
106	GASKET		580-1010000					1	1				
106	GASKET		580-0996000							1	1	1	1
107	MANIFOLD GASKET		580-1045000	1	1	1	1						
107	MANIFOLD GASKET		580-1046000					1	1				
107	MANIFOLD GASKET		580-1047000							1	1	1	1
108	GASKET LOWER		580-1048000	1	1	1	1						
108	GASKET LOWER		580-1049000					1	1				





Some part details may have changed since publication of this manual.

**Contact Rinnai to confirm spare parts details before ordering.**

2017 / 2018 AM SERIES

Effective: 23/01/18 Issue 01

NO	Part Name	RA Part No.	Parts Code	REU-AM2626WD-AK	REU-AM2626WD-50-AK	REU-AM2626WDL-AK	REU-AM2626WDL-50-AK	REU-AM2024WD-AK	REU-AM2024WD-50-AK	REU-AM1620WD-AK	REU-AM1620WD-50-AK	REU-AM1220WD-AK	REU-AM1220WD-50-AK
108	GASKET LOWER		580-1050000							1	1	1	1
110	BUNSEN BURNER		157-154-000	19	19	19	19	15	15	12	12	12	12
111	BURNER SUPPORT REAR		538-6958000	1	1	1	1						
111	BURNER SUPPORT		538-6955000					1	1				
111	BURNER SUPPORT REAR		538-6954000							1	1	1	1
112	CC FRONT PLATE		019-5315000	1	1	1	1						
112	CC FRONT PLATE		019-5302000					1	1				
112	CC FRONT PLATE		019-5301000							1	1	1	1
113	GASKET		580-1015000	1	1	1	1						
113	GASKET		580-1012000					1	1				
113	GASKET		580-1011000							1	1	1	1
114	ELECTRODE FROD A SERIES	92099664	202-278-000	1	1	1	1	1	1	1	1	1	1
115	ELECTRODE A2626 A2426	92099666	202-280-000	1	1	1	1						
115	ELECTRODE A2024 A1620	92099668	202-279-000					1	1	1	1	1	1
116	GASKET ELECTRODE A SERIES	92099670	580-1013000	1	1	1	1	1	1	1	1	1	1
117	ELECTRODE BRACKET		506-189-000	1	1	1	1	1	1	1	1	1	1
118	SLEEVE ELECTRODE 2626/32 V1616	92087030	518-035-000	1	1	1	1	1	1	1	1	1	1
119	BURNER ASSY A2626 A2426	92099672	157-155-000	1	1	1	1						
119	BURNER ASSY A2024	92099674	157-156-000					1	1				
119	BURNER ASSY A1620	92099676	157-157-000							1	1	1	1
125	HEAT EXCH A2626WB WG A2426WG	92099678	314-0056000	1	1	1	1						
125	HEAT EXCH A2024	92099682	314-0058000					1	1				
125	HEAT EXCH A1620WB A1620WG	92099684	314-0059000							1	1	1	1
126	CC BRACKET		538-6956000	1	1	1	1	1	1	1	1	1	1



Some part details may have changed since publication of this manual.

**Contact Rinnai to confirm spare parts details before ordering.**

2017 / 2018 AM SERIES

Effective: 23/01/18 Issue 01

NO	Part Name	RA Part No.	Parts Code	REU-AM2626WD-AK	REU-AM2626WD-50-AK	REU-AM2626WDL-AK	REU-AM2626WDL-50-AK	REU-AM2024WD-AK	REU-AM2024WD-50-AK	REU-AM1620WD-AK	REU-AM1620WD-50-AK	REU-AM1220WD-AK	REU-AM1220WD-50-AK
127	WATER CONNECTION PIPE RET		538-745-000	1	1	1	1	1	1	1	1	1	1
128	HOT WATER PIP RETAINE		508-0067000	1	1	1	1	1	1	1	1	1	1
130	EXHAUST PORT		055-0211000	1	1	1	1						
130	EXHAUST PORT		055-0212000					1	1				
130	EXHAUST PORT		055-0210000							1	1	1	1
131	GASKET EXHAUST FLUE VR2626WGP	92098904	580-599-000	1	1	1	1						
131	FLUE OUTLET PACKING		580-592-000					1	1				
131	FLUE OUTLET PACKING		580-593-000							1	1	1	1
132	MAIN BODY SEAL PACKING -4		580-0393000	1	1	1	1	1	1	1	1	1	1
150	FAN MOTOR ASSY		222-750-000	1	1	1	1						
150	FAN MOTOR ASSY		222-749-000					1	1	1	1	1	1
151	FAN CASE		098-9331000	1	1	1	1						
151	FAN CASE		098-9352000					1	1				
151	FAN CASE		098-9353000							1	1	1	1
152	FAN COMB ASSY A2626 A2426	92099688	222-755-000	1	1	1	1						
152	FAN COMB ASSY A2024	92099690	222-756-000					1	1				
152	FAN COMB ASSY A1620	92099692	222-757-000							1	1	1	1
400	INLET WATER 1/2 V1620/WG/WB/WS	92097906	333-300-000							1	1	1	1
400	INLET WATER 3/4 VRM2632WC	92095901	333-483-000	1	1	1	1	1	1				
401	PLUG BAND		553-119-000	1	1	1	1	1	1	1	1	1	1
402	FILTER WATER 0 LARGE	92083773	196-062-000	1	1	1	1	1	1	1	1	1	1
404	RECTIFIER WATER V2632WC	92093552	330-107-000	1	1	1	1	1	1	1	1	1	1
406	WATER FLOW ASSY A SERIES	92099694	301-259-000	1	1	1	1	1	1	1	1	1	1



Some part details may have changed since publication of this manual.

**Contact Rinnai to confirm spare parts details before ordering.**

2017 / 2018 AM SERIES

Effective: 23/01/18 Issue 01

NO	Part Name	RA Part No.	Parts Code	REU-AM2626WD-AK	REU-AM2626WD-50-AK	REU-AM2626WDL-AK	REU-AM2626WDL-50-AK	REU-AM2024WD-AK	REU-AM2024WD-50-AK	REU-AM1620WD-AK	REU-AM1620WD-50-AK	REU-AM1220WD-AK	REU-AM1220WD-50-AK
407	WATER FLOW SERVO COVER		098-3287000	1	1	1	1	1	1	1	1	1	1
410	OUTLET WATER A1620WB A1620WG	92099696	333-592-000							1	1	1	1
410	OUTLET WATER A1620WSA2626A2024	92099698	333-593-000	1	1	1	1	1	1				
411	WATER PLUG BAND		553-043-000	1	1	1	1	1	1	1	1	1	1
412	VALVE PRESS RELIEF VR3237WG	92099944	337-152-000	1	1	1	1	1	1	1	1	1	1
700	PCB MAIN AM SERIES	92099778	210-0460000	1		1		1		1		1	
700	PCB MAIN 50C A SERIES	92099702	210-0451000		1		1		1		1		1
701	IGNITER BRACKET		537-1362000	1	1	1	1	1	1	1	1	1	1
702	PC BOARD COVER		098-9419000	1	1	1	1	1	1	1	1	1	1
703	SPARKER A SERIES	92099704	211-276-000	1	1	1	1	1	1	1	1	1	1
704	LEAD HT VR2626WGP	92098994	203-264-000	1	1	1	1	1	1	1	1	1	1
705	SENSOR MR V2632FFUG VM2632FFUC	92099988	243-199-000	1	1	1	1	1	1	1	1	1	1
706	OHS A SERIES	92099706	234-623-000	1	1	1	1	1	1	1	1	1	1
707	HARNESS GAS A SERIES	92099708	290-2844000	1	1	1	1	1	1	1	1	1	1
708	HARNESS HEATER A SERIES	92099710	235-498-000	1	1	1	1	1	1	1	1	1	1
710	HARNESS POWER A2626 A2426	92099712	290-2854000	1	1	1	1						
710	HARNESS POWER A2024 A1620	92099714	290-2845000					1	1	1	1	1	1
711	HARNESS MAIN A2024 A1620	92099716	290-2919000					1	1	1	1	1	1
711	HARNESS MAIN A2626 A2426	92099718	290-2920000	1	1	1	1						
712	HARNESS HEATER TO PCB A SERIES	92099720	290-2921000	1	1	1	1	1	1	1	1	1	1
713	FUSE THERMAL A1620	92099722	290-2851000							1	1	1	1
713	FUSE THERMAL A2626 A2024 A2426	92099724	290-2852000	1	1	1	1	1	1				
714	THERMAL FUSE BRACKET		537-1363000	4	4	4	4	4	4	4	4	4	4



Some part details may have changed since publication of this manual.

**Contact Rinnai to confirm spare parts details before ordering.**

2017 / 2018 AM SERIES

Effective: 23/01/18 Issue 01

NO	Part Name	RA Part No.	Parts Code	REU-AM2626WD-AK	REU-AM2626WD-50-AK	REU-AM2626WDL-AK	REU-AM2626WDL-50-AK	REU-AM2024WD-AK	REU-AM2024WD-50-AK	REU-AM1620WD-AK	REU-AM1620WD-50-AK	REU-AM1220WD-AK	REU-AM1220WD-50-AK
715	THERMAL FUSE FIXING PLATE		537-1001000	6	6	6	6	4	4	4	4	4	4
716	HARNESS ANTIFROST A SERIES	92099726	235-499-000	1	1	1	1	1	1	1	1	1	1
717	CLIP HEATER 2402 V2626/32 CUG1	92076123	537-174-000	1	1	1	1	1	1	1	1	1	1
718	HEATER BRACKET		537-1364000	2	2	2	2	2	2	2	2	2	2
719	THERMISTOR SINGLE A SERIES	92099728	233-332-000	1	1	1	1	1	1	1	1	1	1
720	THERMISTOR TWIN A SERIES	92099730	233-331-000	1	1	1	1	1	1	1	1	1	1
721	ELEC CORD A SERIES	92099732	206-366-000	1	1	1	1	1	1	1	1	1	1
722	HARNESS REMOTE CONTROL V1620WG	92099961	290-1288000	1	1			1	1	1	1	1	1
722	HARNESS A REMOTE VRM2626WD	92099436	290-2490000			1	1						
723	RELAY AM SERIES	92099760	210-0459000	1	1	1	1	1	1	1	1	1	1
724	HARNESS RELAY AM SERIES	92099764	290-2939000	1	1	1	1	1	1	1	1	1	1
807	TAPPING SCREW		501-737-000	1	1	1	1	1	1	1	1	1	1
808	THERMISTOR FIXING SCREW		501-295-000	1	1	1	1	1	1	1	1	1	1
809	SCREW		501-0064000	1	1	1	1	1	1	1	1	1	1
820	O RING (S4) TEST POINT 371TR	90195165	520-300-010	2	2	2	2	2	2	2	2	2	2
821	O RING GAS CON 2010 V1616/20WG	92072859	520-043-010	1	1	1	1	1	1	1	1	1	1
822	PACKING		580-157-000	1	1	1	1	1	1	1	1	1	1
825	O RING THERMISTOR 2010 2402	92062249	520-209-010	1	1	1	1	1	1	1	1	1	1
826	O RING 2010 2402 V1616/20WG	92062348	520-281-010	1	1	1	1	1	1	1	1	1	1
828	O RING HEAT EXCH 2010/24WA V16	92062207	520-193-010	2	2	2	2	2	2	2	2	2	2
829	O RING HEAT EXCH 2010/24WA	92062199	520-048-010	1	1	1	1	1	1	1	1	1	1
830	O RING IN/OUT WATER 2402 V1616	92071182	520-049-010	1	1	1	1	1	1	1	1	1	1