

# Demand Duo Systems

## Operation & Installation Manual

# Rinnai

Congratulations on the purchase of your Rinnai Demand Duo System. We trust you will have many years of comfort and enjoyment from your appliance.



### **BEFORE USING THIS APPLIANCE**

Before proceeding with the operation or installation read this manual thoroughly and gain a full understanding of the appliance, to ensure safe and correct use.

### **IMPORTANT NOTICE FOR INSTALLERS**

Please leave these instructions with the end user after commissioning of the system and alert the end user of the content sections "Warnings and "Periodic Inspection" and "Maintenance".

Not suitable as a pool or spa heater.

This manual must be read and understood before installation, commissioning and operation of water heaters and flue systems are attempted. The information contained in other Operating / Installation instructions supplied with water heaters applies in full, unless otherwise dictated in this manual.

This appliance must be installed in accordance with:

- Manufacturer's Installation Instructions
- Current AS/NZS 3000, AS/NZS 3500, AS/NZS 5601
- Plumbing Code of Australia (PCA)
- Local regulations, including local OH&S requirements, and Municipal Building Codes, including the National Construction Code (NCC).

These products comply with the lead-free requirements of the National Construction Code – Volume 3.

This appliance must be installed, maintained and removed ONLY by an Authorised Person. Rinnai recommends that this appliance be serviced once a year.

For continued safety of this appliance it must be installed and maintained in accordance with the manufacturer's instructions.



The Australian Gas Association  
All Rinnai gas products sold in Australia are A.G.A. certified.



**Lead Free**  
This Appliance complies with current AS 3498 LIC. WMKA00169



**Lead Free**  
This Appliance complies with current AS 3498 LIC. WMKA00208



**Lead Free**  
This Appliance complies with current AS 3498 LIC. WMKA21244



**Lead Free**  
This Appliance complies with current AS 3498 LIC. 60215



Scan QR to register your warranty

# TABLE OF CONTENTS

<b>Warnings &amp; Safety</b>	<b>4</b>
Regulatory Information .....	4
Notice to Victorian Consumers .....	5
Safety .....	5
Scald Hazards .....	6
<b>Important Information</b>	<b>7</b>
Safety Devices .....	7
<b>Care &amp; Maintenance</b>	<b>8</b>
<b>Installation Instructions</b>	<b>10</b>
Regulations .....	10
Appliance Location .....	10
HD28e, HD32e, HD210e, HDC32 (External models) .....	10
HD28I, HD210I, HDC32 (Internal models) .....	11
Horizontal Obstructions .....	11
Horizontal Flue Terminal Clearances (Extract from AS/NZS 5601) .....	12
Co-Axial Flueing for Internal Models .....	13
Multiple Flue Terminals .....	14
Installation Options .....	15
Assembly .....	16
<b>Specifications</b>	<b>21</b>
<b>Installation Handover Manual</b>	<b>41</b>
Cold Water Supply .....	41
Hot Water Outlet .....	41
Return Pump .....	41
Gas Supply .....	41
Electrical Supply .....	41
Filling Instructions .....	42
Starting Instructions .....	42
Demand Duo Principle of Operation .....	42
Thermostatic Controller Operation .....	43
Demand Duo Preventative Maintenance .....	43
Tank .....	43
Primary Pump .....	43
Heavy Duty (HD) Heat Source .....	44
Flue Length Dipswitches - REU-VCM .....	44
<b>Fault Finding</b>	<b>45</b>
Ringmain Pump .....	46
Service .....	46
Details .....	47
Commercial Hot Water System Commissioning Check-List .....	47
<b>Commissioning</b>	<b>47</b>
<b>Contacts</b>	<b>52</b>

# WARNINGS & SAFETY



## READ ALL INSTRUCTIONS BEFORE USING THE APPLIANCE.

Always comply with the following precautions to avoid dangerous situations and to ensure optimum performance.

Failure to carefully read and follow all instructions in this manual can result in equipment malfunction, property damage, personal injury and/or death.

**DANGER:** Indicates an imminently hazardous situation which, if not avoided, will result in personal injury or death.

**WARNINGS:** Indicates a potentially hazardous situation which, if not avoided, could result in personal injury or death.

**CAUTIONS:** Indicates a potentially hazardous situation which, if not avoided, could result in minor or moderate injury or damage to the appliance. It may also be used to alert against unsafe practices.



## REGULATORY INFORMATION

This appliance shall be installed in accordance with these instructions and all regulatory requirements which exist in your area including those in relation to manual lifting, working at heights and on roofs. Applicable publications and regulations may include:

- AS/NZS 3500 National Plumbing and Drainage, AS/NZS 3000 Wiring rules, AS/NZ 5601 Gas Installations & Building Codes of Australia (BCA)
- Local regulations, including local OH&S requirements, and Municipal Building Codes, including the National Construction Code (NCC).
- Plumbing Code of Australia (PCA)
- Local Regulations and Municipal Building Codes

**DO NOT** operate this system before reading the manufacturers instructions.

This appliance must be installed, commissioned and serviced by an authorised person in accordance with all applicable local rules and regulations.

For continued safety of this appliance it must be installed, operated and maintained in accordance with the manufacturer's instructions.

This appliance is heavy, use 2 people or mechanical lifting device. Improper lifting may result in serious injury.

**DO NOT** modify the electrical wiring of this appliance. If the control power wiring is damaged or deteriorated then it must be replaced only by an authorised person. Failure to do so may result in electric shock, fire, serious injury or product failure.

Care should be taken not to touch the pipe work as it may be HOT!

**DO NOT** place articles on or against this appliance.

**DO NOT** store chemicals or flammable materials near this appliance.

**DO NOT** operate with panels, covers or guards removed from this appliance.

**DO NOT** remove covers while power is on.

**DO NOT** enclose this appliance.

**DO NOT** activate pump unless cylinder is full of water.

Not suitable as a pool or spa heater.

All Rinnai Demand Duo (DD) systems and components are Watermark Certified by SAI Global as applicable.

The Rinnai DD1 model is certified as a gas storage water heater by the Australian Gas Association (AGA). AGA Certification applies to DD1 models only. AGA Certification does not apply to other DD models in this manual.

All dimensions referred to in these instructions are in millimetres, unless otherwise specified.



## A NOTE ON ILLUSTRATIONS

The illustrations used in this manual are for explanatory purposes only and the shape of your unit may vary slightly from that which is shown in this manual.



**MANDATORY INSPECTION PRIOR TO INSTALLATION**

Immediately report any damage or discrepancies to the Supplier of the appliance. This appliance was inspected and tested at the time of manufacture and packaging, and released for transportation without known damage. Upon receipt, inspect the exterior for evidence of rough handling in shipment. Ensure that the appliance is labelled correctly for the gas and electrical supply, and/or other services it is intended to be connected to.

For safety and warranty purposes, appliances that may be damaged or incorrect must not be installed or operated under any circumstances. Installation of damaged or incorrect appliances may contravene local government regulations. Rinnai disclaims any liability or responsibility whatsoever in relation to the installation or operation of damaged or incorrect appliances.

**NOTICE TO VICTORIAN CONSUMERS**



This appliance **MUST** be installed by a person licensed with the Victorian Building Authority. **ONLY** a licensed person will have insurance protecting their workmanship.

Make sure you use a licensed person to install this appliance and ask for your Compliance Certificate.

For further information contact the Victorian Building Authority on 1300 815 127

**SAFETY**



This appliance is **NOT** intended for use by persons (including children) with reduced physical, sensory or mental capabilities, or lack of experience and knowledge unless they have been given supervision or instruction concerning use of the appliance by a person responsible for their safety.

Children should be supervised to ensure that they **DO NOT** play with the appliance.

Any power leads from the water heater system components **MUST** be plugged into an external weatherproof electrical outlet. If the power supply cord of the system is damaged, it **MUST** be replaced by an authorised person in order to avoid a hazard, using genuine replacement parts available from Rinnai. Take care of not to touch the power plugs with wet hands.

If the supply cord is damaged, it must be replaced by the manufacturer, its service agent or similarly qualified persons in order to avoid a hazard.

**DO NOT** touch the unit cover or the flue outlet.

**DO NOT** insert objects into the flue outlet.

**DO NOT** spray water directly into the flue outlet.

Keep, trees, shrubs, etc. well clear of the flue outlet.

On colder days steam may discharged from the flue outlet. This condition is normal for high efficiency appliances and does not indicate a fault.

**DO NOT** Spray aerosols in the vicinity of this appliance while it is in operation.

**DO NOT** use or store flammable materials in or near this appliance.

**DO NOT** place articles on or against this appliance.

**DO NOT** modify this appliance.

**DO NOT** store pool chemicals near this appliance.

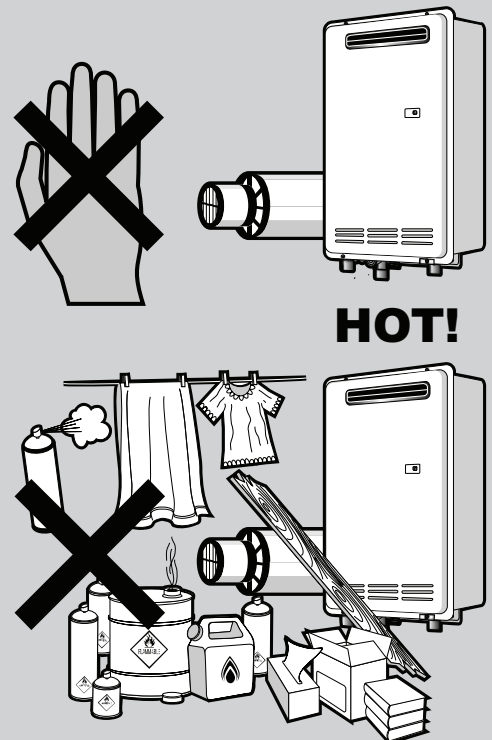

**Hydrogen Gas**

If the hot water heater is not used for two weeks or more, a quantity of hydrogen gas, which is highly flammable, may accumulate in the water heater. To dissipate this safety, it is recommended that a non electrically operated hot tap be turned on for several minutes at a sink, or bath, but not a dishwasher or other appliance. During this procedure there must be no smoking, open flame or any electrical appliance operating nearby. If hydrogen gas is discharged through the tap, it will probably make a sound like air escaping.

**Water Temperature**

To meet regulatory requirements the temperature of stored water **MUST NOT** be less than 60°C. The temperature controller is factory pre-set to 65°C. The outlet temperature setting of the gas continuous flow heater is factory pre-set to 75°C.



This appliance may deliver water at high temperature. Refer to the Plumbing Code of Australia (PCA), local requirements and installation instructions to determine if additional delivery temperature control is required.



The temperature controller setting must only be adjusted by suitably qualified trades person.

**SCALD HAZARDS**



**Hot Water can cause scalds.**

**Children, disabled, and the elderly are at the highest risk of being scalded.**

**Feel water temperature before bathing or showering.**

**Scalds from hot water taps can result in severe injuries to young children.**

**Scalds can occur when children are exposed directly to hot water when they are placed into a bath which is too hot.**

**Always.....**

Test the temperature of the water with your elbow before placing your child in the bath, also carefully feel water before bathing or showering yourself.

Supervise children whenever they are in the bathroom.

Make sure that the hot water tap is turned off tightly.

**Consider.....**

Installing child proof tap covers or child resistant taps (both approaches will prevent a small hand being able to turn on the tap).

Installing tempering valves or thermostatic mixing valves which reduce the hot water temperature delivered to the taps. Your local plumbing authority may already require that these be fitted. Contact your installer or local plumbing authority if in doubt.

**Never....**

Leave a toddler in the care of another child. They may not understand the need to have the water temperature set at a safe level.

# IMPORTANT INFORMATION

## SAFETY DEVICES

For safe operation this water heater is fitted with a combination Pressure & Temperature Relief Valve, a temperature controller and an over-temperature cut out on each heater.



**DO NOT** tamper with or remove safety devices.

**DO NOT** operate this water heater unless all safety devices are fitted and in working order.

The operation of the thermal cut out indicates a possibly dangerous situation. **DO NOT** reset the thermal cut out until the water heater has been serviced by a qualified person.

## Pressure & Temperature Relief (PTR) Valve

This valve is located near the top of the storage tank and is essential for safe operation.



**DO NOT** seal or block the outlet of the PTR valve or its drain pipe.

**DO NOT** replace the PTR valve with one that has a higher pressure rating than is specified for the water heater.

The PTR valve should be checked for performance or replaced at intervals not exceeding 5 years, or more frequently in areas with a high incidence of water deposits by a qualified person. The easing gear must be operated at least once every six months or more frequently in areas with a high incidence of water deposits.



**Failure to do this may result in the water heater cylinder failing or under certain circumstances, exploding. Water discharged will be very hot. Exercise care to avoid scald injury. If the valve does not seal again when the easing gear is closed, contact Rinnai to arrange inspection by a qualified person.**

It is important you raise and lower the easing gear gently. If the valve does not discharge water when the easing gear lever is lifted, there may be a serious problem and the power supply to the system must be switched off immediately. Contact Rinnai to arrange inspection by a qualified person.

It is normal for the PTR valve to release a small quantity of water through the drain pipe during heating. If the valve dribbles or leaks continuously, try easing the valve gear for a few seconds. This may dislodge any foreign matter and stop leakage. If leakage does not stop there may be a problem as detailed below:

- If there are heavy flows of water until the water heater is cold which then stops until the water reheats there may be a serious problem and the power supply to the system must be switched off immediately. Contact Rinnai to arrange inspection by a qualified person.
- If there is a steady flow for long periods, often at night, it may be as a result of the water pressure exceeding the design pressure of the water heater. Contact your installing plumber as a Pressure Limiting Valve (PLV) may be required.

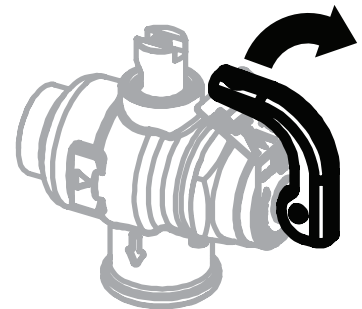

**Gently lift lever until water flows from drain line, lower lever gently to close**

## Expansion Control Valve (ECV)

An ECV is recommended in all geographical areas where the water supply has a tendency to cause scaling, including South Australia and Western Australia. Local regulatory authorities may require that an ECV be fitted. The ECV is to be supplied and fitted by the installer. Refer to the section Water Quality for more information on scaling water.

If an ECV is fitted, operate the easing gear at least once every six months to remove any deposits and to verify that it is not blocked.

The ECV should be checked for performance or replaced at intervals not exceeding 5 years, or more frequently in areas with a high incidence of water deposits by a qualified person.

It is normal and desirable that the ECV allows a small quantity of water to be discharged through the drain pipe during the heating cycle. If the valve dribbles or leaks continuously, operate the easing gear for a few seconds. This may dislodge any foreign matter and stop leakage. If leakage does not stop Contact Rinnai to arrange inspection by a qualified person.

# CARE & MAINTENANCE

## WATER QUALITY

The water quality of most public supplies is suitable for the water heating system. The water quality from bore wells is generally unsuitable for the water heating system. Refer to the 'Warranty Conditions' for water quality parameters and how they affect the warranty conditions. If in doubt about the water quality, have it checked against the parameters listed in the warranty conditions. If sludge or foreign matter is present in the water supply, a suitable strainer filter should be incorporated in the water supply to the system.

## DRAINING



Draining **MUST** be carried out by a qualified person.

Water may be **HOT** during draining.

Drain the storage tank(s) as follows:

1. Isolate or turn 'OFF' the water heater at the electricity supply.
2. Close the cold water isolation valve at the inlet to the storage tank(s).
3. Close the water isolation valve at the return port from the gas water heater(s) on the storage tank(s).
4. Close the hot water isolation valve at the outlet of the storage tank(s).
5. Operate the PTR valve easing gear - gently. Operating the PTR valve easing gear will relieve the pressure in the water heater.
6. Undo the cold water inlet union. Attach a hose to the water heater side of the union. Let the other end of the hose go to a drain.
7. Operate the PTR valve easing gear again. This allows air into the water heater and will result in water draining through the hose.

## PERIODIC MAINTENANCE & SERVICING

Rinnai service network personnel are fully trained and equipped. If your Rinnai appliance requires servicing contact Rinnai as per the details on the back page of this manual. Rinnai recommends that this commercial appliance be inspected and serviced by a qualified person every 12 months.

If overflow tray and drain are fitted, it is the users responsibility to have these checked periodically to ensure there are no blockages.

The user should operate the easing gear of the ECV and PTR valve (if fitted) every 6 months as described under "Safety Devices" on page 7.

The pressure and temperature relief valve and expansion control valve **MUST** be checked for performance or replaced by an authorised person at intervals not exceeding 5 years or more frequently in areas where the water is classified as scaling water (see 'Water Quality').

If the electric conduit, power supply cord or plug to hot water system is damaged, they **MUST** be replaced by an authorised person in order to avoid a hazard. The power supply cord and plug must be replaced by a genuine replacement part available from Rinnai.

**SAVE A SERVICE CALL**

Check the items below before requesting a service. Service and parts charges may be incurred where it is found that there is no fault with the water heater and the issue is related to the plumbing installation or is due to the failure of water or electric supplies.

<b>Insufficient or no hot water</b>	
Is the electricity supply connected?	Check that the isolating switch marked "HOT WATER" or "WATER HEATER" at the meter box is switched on. Check also that any isolating switches installed near the water heater are switched on.
	Check the fuse or circuit breaker marked "HOT WATER" or "WATER HEATER" at the meter box. Repeated failure of fuse or tripping of circuit breaker indicates a fault which must be investigated by an authorised trades person.
Is there insufficient gas supply for gas heater(s)?	Check gas is available and turned 'ON'.
	Check the isolation valve in the gas line is opened.
	Refer to your plumber to ensure the gas line has been purged of air after installation.
Are you using more hot water than you think?	Often end users are surprised at the amount of hot water used, especially when showering. If the amount of hot water used during the day exceeds the storage capacity of the hot water system, it is likely that there will be insufficient hot water. Has your plumber install water saving fixture and/or flow control or pressure limiting valves to reduce consumption.
Thermostat settings?	Check the temperature of hot water delivered with a thermometer placed under the closest outlet (usually the kitchen sink) on a non-tempered hot water line. The temperature of the water delivered should be at least 55°C (allowing for heat losses in pipe work). If this is not the case, the temperature may need to be increased. Contact your installer or Rinnai to discuss adjusting the thermostat.
No water from the hot tap?	Restriction in the hot tap or failure of the cold water supply to the heater. Check for water flow at the other hot taps and that the cold water isolation valve is fully open.
Is the Primary Pump operating correctly?	Check the controller screen information to verify the primary pump is operational relative to the tank temperature set point. Use the maintenance function for the controller to test the pump operation. Refer to separate manual for controller functionality.
Is the controller showing an error?	Refer to separate manual for the controller functionality.
Are the cold water filters clean on the gas water heater(s)?	Isolate and remove the water filter at the cold water connection point. Refer to separate manual for the gas continuous flow water heater operation.

# INSTALLATION INSTRUCTIONS

These instructions apply to the Demand Duo (DD) range of Rinnai hot water systems ranging from one Heavy Duty continuous flow water heater coupled with one storage tank up to 12 heavy Duty continuous flow water heaters coupled with multiple tanks:

## REGULATIONS

For continued safety of this appliance it must be installed, operated and maintained by authorised person in accordance with manufacturer's instructions, current with AS/NZS 3500 and AS/NZS 5601, local regulations and municipal building codes.

Rinnai Demand Duo hot water systems are not suitable or approved as pool heater.

Read these instructions carefully before proceeding with the installation.

## APPLIANCE LOCATION

Ensure reasonable access for installation, servicing and removal. All valves, controls and pumps etc must be easily accessible.

Rinnai Demand Duo tanks and any free standing frames must be mounted on a solid level base, capable of supporting the weight of the appliance when full of water. Ensure components are not allowed to stand in water. Spacers under the tank are recommended in wet areas.

All Rinnai Demand Duo tanks are "left handed" with the water connections to the left when viewing the thermistor housing from the front.

These systems are combined with Rinnai HD series, HD28e (VCM2837WC), HD28i (VCM2837FFUC), HD32e (AM3237WC), HD210e (N3237WC), HD210i (N3237FFC) and HDC32 (NB3237).

Rinnai HD units are fan assisted appliances and thus have lower clearances than a natural draft appliance of the same MJ rating.

## HD28E, HD32E, HD210E, HDC32 (EXTERNAL MODELS)

This appliance is designed for 'Outdoor' Installation only. As such, it must be located in an above ground open air situation with natural ventilation, without stagnant areas, where gas leakage and products of combustion are rapidly dispersed by wind and natural convection.

This appliance must be mounted on a vertical structure with the water and gas connections on the underside pointing downwards. For appliances installed on elevated structures or under floors specific requirements apply. Refer to AS/NZS 5601 Section 6 for details.

This appliance must not be used as a domestic spa or swimming pool heater.

Location of the appliance flue terminal must be in accordance with Section 6 and Figure 6.2 of AS/NZS 5601. Figure 6.2 is reproduced in the 'Horizontal Flue Terminal Clearances' section of these instructions.



**AS/NZS 5601 is current at the time of printing. It is the installers' responsibility to ensure current requirements are met.**

**HD28I, HD210I, HDC32 (INTERNAL MODELS)**

This appliance is designed for 'Indoor' installation only. It may be installed 'Outdoors' in an enclosure if the requirements of AS/NZS 5601 Section 6 are satisfied. An enclosure is defined as a compartment, enclosed area of partitioned off space primarily used for the installing of the appliance.

If installed in an enclosure either Internally or Externally, the location should be ventilated to allow gas to dissipate and provision must be made for the safe disposal of any leaking water to a visible location.

This appliance must not be used as a domestic spa or swimming pool heater.

Two types of flue systems are available:

- The Rinnai Commercial Common Flue System.
- The Rinnai Co-Axial FFU flue system.

The use of non Rinnai flue components may result in a dangerous situation and violates regulations.

The appliance(s) must be located so that the flue terminal exits the building at a suitable point.

For detailed information refer to "FLUEING FOR INTERNAL MODELS" on page 13.

This appliance must be located so that the flue terminal exits the building at a suitable point.

If a horizontal (wall) terminal is used, the location must be in accordance with Section 6 and Figure 6.2 of AS/NZS 5601. Figure 6.2 is reproduced under 'HORIZONTAL FLUE TERMINAL CLEARANCES' on page 12 of this manual.

If a vertical (roof) terminal is used, the location must be in accordance with Section 6 of AS/NZS 5601 and the 'FLUEING FOR INTERNAL MODELS' on page 12.

**HORIZONTAL OBSTRUCTIONS**

AS/NZS 5601-2010 'Gas Installations' stipulates a minimum horizontal clearance of 500mm between a building structure and obstruction facing the terminal.

For Rinnai External continuous flow water heaters such a building structure must 'obstruct' the full front cover height of the appliance, or extend vertically above and below the front cover.

There must be no partial obstructions to the front cover of the appliance or any other parts of the appliance casing. This will avoid the appliance failing to operate under windy conditions.

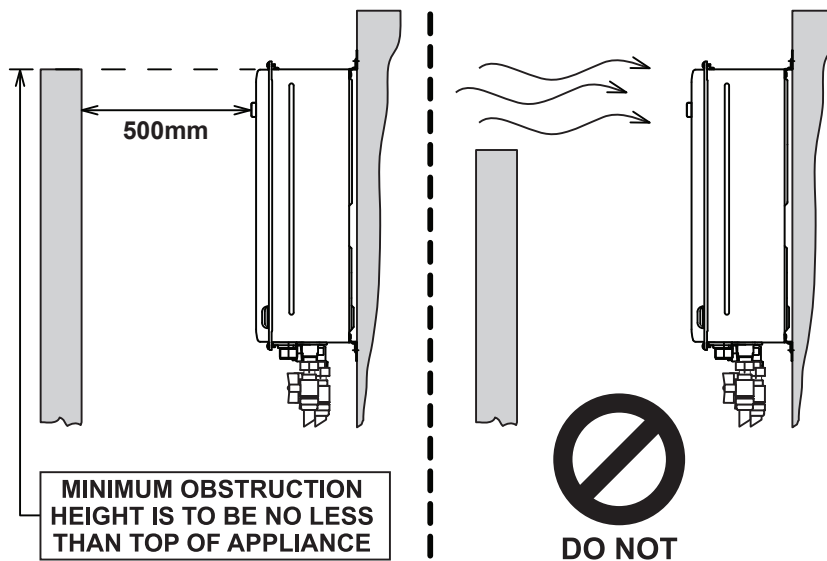

**HORIZONTAL FLUE TERMINAL CLEARANCES (EXTRACT FROM AS/NZS 5601)**

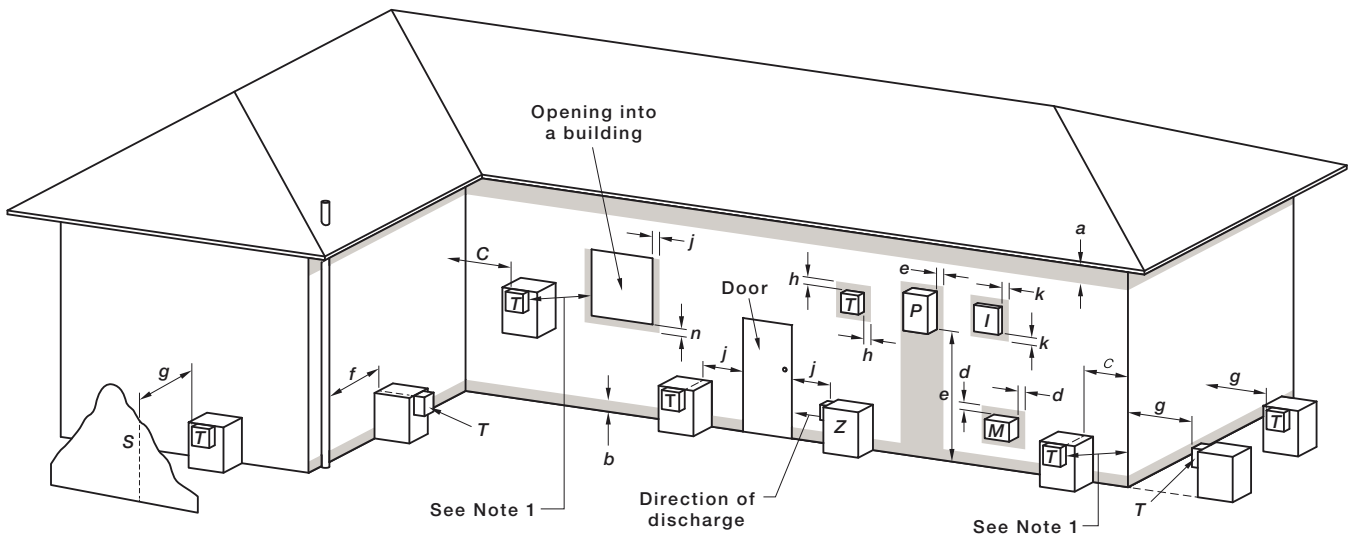

**LEGEND:**

- I** = Mechanical air inlet      **M** = Gas meter      **P** = Electricity meter or fuse box       Shading indicates prohibited area for flue terminals
- S** = Structure      **T** = Flue terminal      **Z** = Fan-assisted appliance only

Ref.	Item	Min. Clearances (mm)	
		Natural draft	Fan assisted
a	Below eaves, balconies and other projections:		
	For appliances up to 50 MJ/h input	300	200
	For appliances over 50 MJ/h input	500	300
b	From the ground, above a balcony or other surface *	300	300
c	Front a return wall or external corner *	500	300
d	From a gas meter (M) (see Note 5) (see Clause 5.11.5.9 for vent terminal location of regulator) (see Table 6.7 for New Zealand requirements)	1000	1000
e	From an electricity meter or fuse box (P) † (see Note 5)	500	500
f	From a drain pipe or soil pipe	150	75
g	Horizontally from any building structure* = or obstruction facing a terminal	500	500
h	From any other flue terminal, cowl, or combustion air intake *	500	300
j	Horizontally from an openable window, door, non-mechanical air inlet, or any other opening into a building with the exception of sub-floor ventilation:		
	Appliances up to 150 MJ/h input *	500	300
	Appliances over 150 MJ/h input up to 200 MJ/h input *	1500	300
	Appliances over 200 MJ/h input up to 250 MJ/h input *	1500	500
	Appliances over 250 MJ/h input *	1500	1500
k	All fan-assisted flue appliances, in the direction of discharge	-	1500
n	From a mechanical air inlet, including a spa blower	1500	1000
	Vertically below an openable window, non-mechanical air inlet, or any other opening into a building with the exception of sub-floor ventilation:		
	Space heaters up to 50 MJ/hr input	150	150
	Other appliances up to 50 MJ/hr input	500	500
	Appliances over 50 MJ/h input and up to 150 MJ/h input	1000	1000
	Appliances over 150 MJ/h input	1500	1500

\* Unless appliance is certified for closer installation.

† Prohibited area below electricity meter or fuse box extends to ground level.

**NOTES:**

- 1 Where dimensions c, j or k cannot be achieved an equivalent horizontal distance measured diagonally from the nearest discharge point of the terminal to the opening may be deemed by the *Technical Regulator* to comply.
- 2 See Clause 6.9.4 for restrictions on a flue terminal under a covered area.
- 3 See Figure J3 for clearances required from a flue terminal to an LP Gas cylinder. A flue terminal is considered to be a source of ignition.
- 4 For minimum clearances not addressed above acceptance should be obtained from the *Technical Regulator*.
- 5 Minimum clearances d and e also apply to any combustion air intake openings of appliances.

FIGURE 6.2 (in-part) LOCATION OF FLUE TERMINALS OF BALANCED FLUE, ROOM-SEALED, FAN-ASSISTED OR OUTDOOR APPLIANCES

**CO-AXIAL FLUEING FOR INTERNAL MODELS**

This system is certified and suitable for use with Rinnai internal commercial continuous flow water heaters.

The Rinnai Flueing system must be installed in accordance with the instructions supplied with the flue terminal. Non Rinnai flueing systems **MUST NOT** be used.

The Rinnai internal flueing system is highly versatile and makes installation of an internal water heater simple and convenient.

The flueing for internal water heaters is a Co-Axial design. It is manufactured from an aluminium or propylene inner flue pipe to discharge product of combustion and a thermoplastic outer pipe for air supply to the appliance. The water heater is a room sealed appliance.

**NOTE:** Each Rinnai water heater is flued individually.

Horizontal flueing can be used as a direct wall flue or extended from another internal wall.

**DD6 Direct Wall Flue**



Vertical flueing is used when the water heater needs to be flued vertically through the roof.

A condensate trap may be required for extended flue runs depending on the type of water heater. Details are provided in the separate flue installation instructions and **MUST** be adhered to.

Rinnai HD internal water heaters are classified as ‘room sealed’ appliances. Flue systems must be installed in accordance with Rinnai Installation Instructions (supplied with flue terminals), local gas fitting regulations, municipal building codes, AS/NZS 5601 and all other relevant statutory regulations.

The flue terminal clearances in AS/NZS 5601 do not apply to the HD28e, HD32e, HDC32 or HD210e heaters installed side by side. These appliance are AGA certified to be located side by side, for both internal an external models

**DD5 typical installation**





Only Rinnai Flueing systems can be used with Internal Water Heaters. Non-Rinnai Flueing systems are not certified and will not be covered under warranty.

For all further information on Internal Flueing, please refer to separate Flueing manual supplied with Flueing components.

### MULTIPLE FLUE TERMINALS

Dimension 'H' in AS/NZS 5601 Figure 6.2 does not apply when multiple Rinnai external water heaters of the same model are installed on the same vertical face with flue terminals at the same height. Under these conditions appliances can abut each other as shown below:

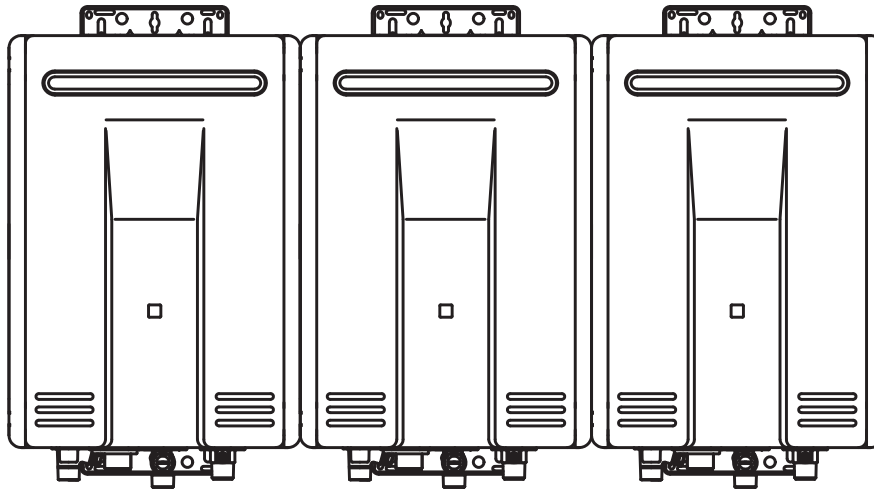

Before commencing installation, ensure you refer to the content of all other Operation / Installation manuals supplied with the appropriate model Rinnai Continuous Flow Water Heater or Rinnai Flueing Systems.

**INSTALLATION OPTIONS**

The Rinnai Commercial Common Flue System is suitable for the Rinnai Internal Commercial Gas Continuous Flow Water Heaters (listed on the cover of this manual) in accordance with the flue design options outlined in the AS/NZS 5601.1 Appendix titled 'Flue Design'. Figure 1 & Figure 2 below, illustrate typical application principles.

**Figure 1. Typical Natural Draft Flue Installation - VRM/VCM-Series ONLY**

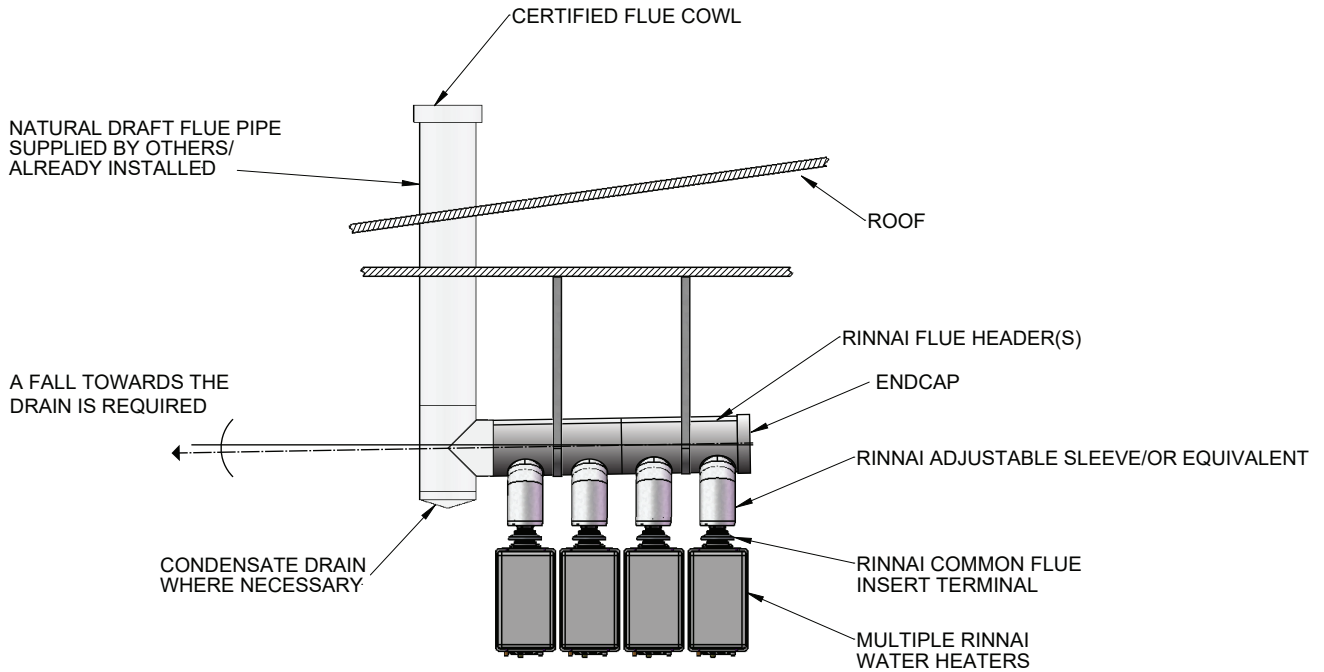

**Figure 2. Typical Power Flue Installation - VRM/VCM Series ONLY**

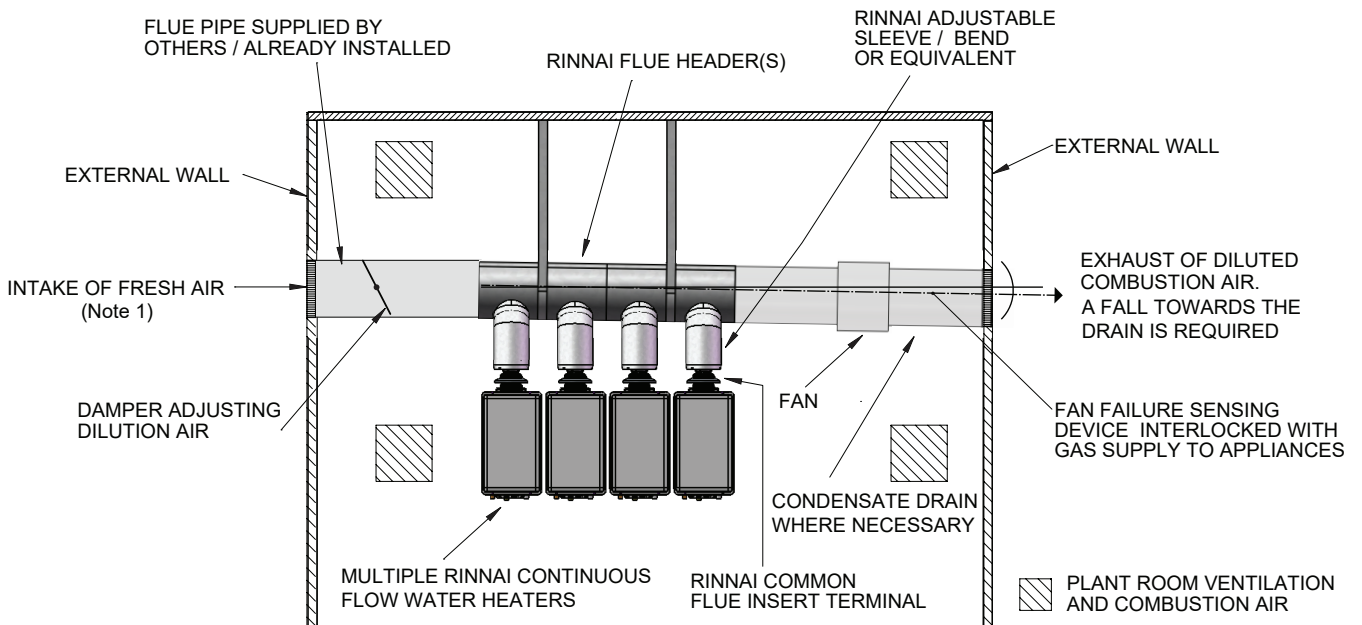

For more information on the flue system, please refer to the Rinnai Commercial Common Flue System Operation & Installation Manual.

### **UNPACKING INTEGRATED STORAGE UNIT WITH ONE GAS HEATER (DD1)**

Remove outer cardboard box. Remove screws attaching feet on tank to wooden pallet. Carefully remove system from pallet and inspect for any transport damage. Ensure that PTR valve and brass plug 32mm supplied in box is located and stored. **DO NOT** install if any components are damaged.

### **UNPACKING SYSTEMS WITH MULTIPLE HEATERS**

#### ***Tank:***

Remove outer cardboard box.

Carefully remove tank from pallet and inspect for any transport damage. Ensure that PTR valve, supplied in box is located and stored. **DO NOT** install if any components are damaged.

#### ***Manifold of HD water heaters:***

With cardboard box in upright position, remove packing straps and slide lid upwards. Remove water heater and frame assembly carefully and place upright in desired location. Repeat this for all manifold modules you have received that are necessary to build the complete system. **DO NOT** install if any components are damaged

### **ASSEMBLY**

#### **Integrated storage unit 250L & 315L with one gas heater (DD1)**

- Position tank in desired position.
- Attach PTR valve supplied in box to 20mm port at top of tank. As for the DD1 28e / 28i 250L or 315L, plug off second port with 20mm plug supplied. For DD1 32e/210e/210i 250L, 315L or HDC32, attach another PTR valve to second port at the top of tank.
- Plug off second cold inlet port at the bottom of the tank with 32mm plug supplied with tank.
- Run PTR valve drains to suitable discharge position.

#### **Integrated storage unit 270L, 330L & 440L with one gas heater (DD1)**

- Position tank in desired position.
- Attach PTR valve supplied in box to 25mm port at top of tank. As for the DD1 28e / 28i 270L, 330L or 440L, plug off second port with 25mm plug supplied. For DD1 32e/210e/210i 270L or 330L, 440L or HDC32, attach another PTR valve to second port at the top of tank.
- Plug off other unused port(s) of the tank with plug(s) supplied with tank.
- Run PTR valve drains to suitable discharge position.

**Demand Duo 2 – Demand Duo 10**

A Rinnai Demand Duo is supplied in modules. The storage tank(s) are separate and the heat source is made up of either 2 or 3 HD continuous flow units plumbed in parallel and mounted on a dedicated and lightweight frame. Standard systems are connected together by coupling the barrel unions supplied with the copper header pipes. Specifically engineered systems (generally for larger projects or restrictive plant areas) will be marked up accordingly to aid the assembly process.

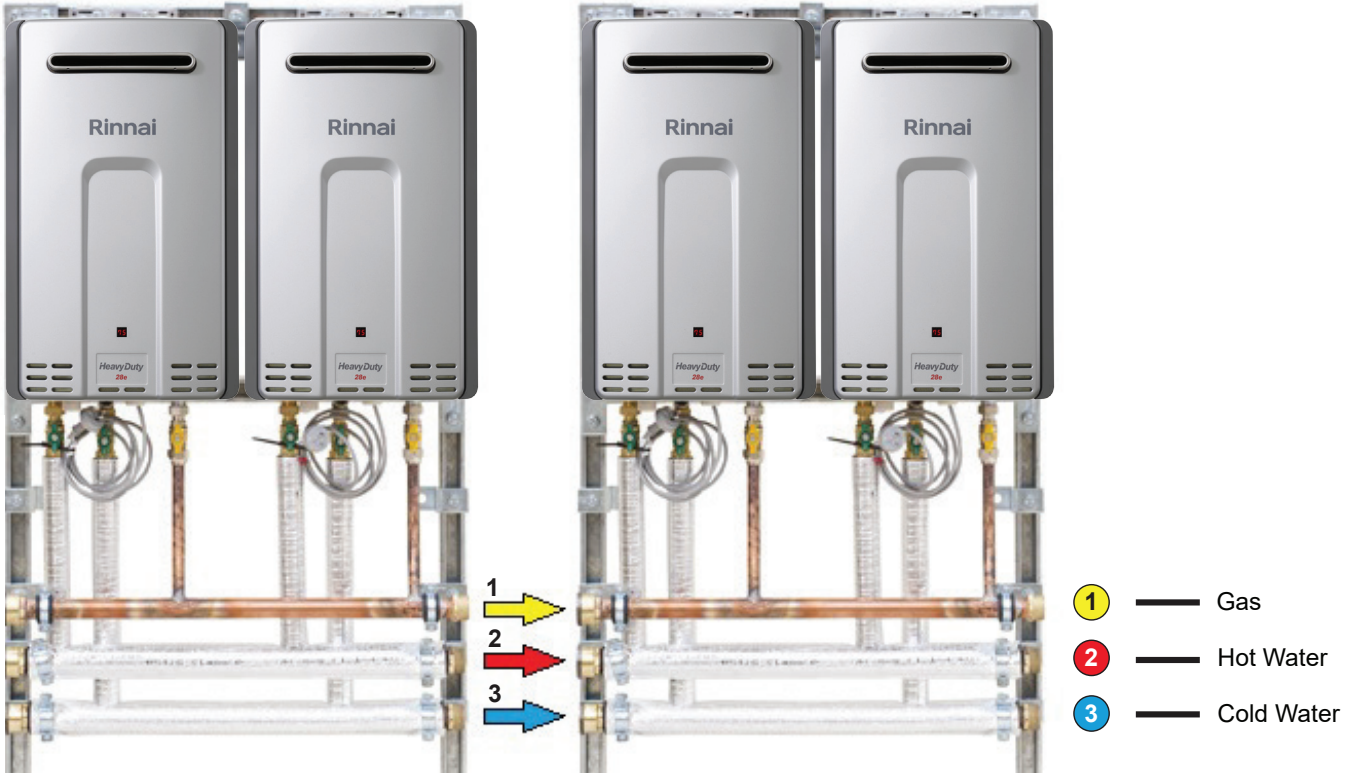

**Wall mounting or floor mounting of the heat source is possible.**

**Wall mounting** - drill holes in the wall in the desired location and mount the frame to the wall using suitable fixings. A useful nominal height is 1500mm (height of the frame) from floor level. This is subject to site requirements, the desired location of the flue terminal in reference to AS/NZS5601 (page 12) and service accessibility. If you are installing an internal plant, flue design and the associated wall or roof penetrations need to be considered as the centre distance between the heaters varies depending on which heater is being installed. Refer to the drawings and specifications section from page 27 for dimensional information.

**Floor mounting** - you will require the appropriate number of DDBASE to enable suitable floor mounting. DDBASE requires some minor assembly using the brackets and fixings provided. Every module of either 2 or 3 heaters requires one DDBASE and it is recommended to assemble the DDBASE to the heat source module(s) prior to joining the pipework. The heat source can also be installed in a back to back configuration using DDFJOINKIT.

Again if you are installing an internal plant, flue design and the associated wall or roof penetrations need to be considered as the centre distance between the heaters varies depending on which heater is being installed. Refer to the drawings and specifications section from page 27 for dimensional information.

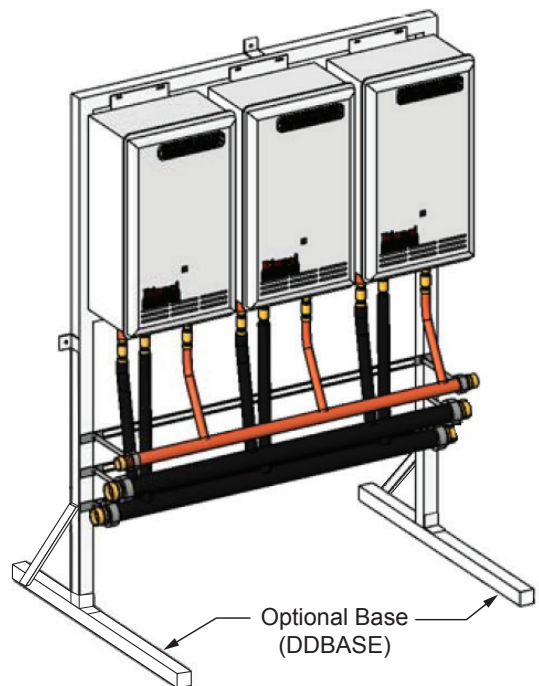



**When direct flueing through the wall that the water heaters are mounted on, it may be necessary to attach flue to water heater and push it through the wall before attaching the water heater to the wall.**

Specifically engineered systems mounted on a skid base do not require any assembly of the heat source unless it has been split purely for transport purposes. If this is the case the pipe connections will be marked up accordingly to aid the assembly process.

The tank(s) and the primary pump must be installed as close as possible to the heat source to minimise pipe runs. A Demand Duo PLUS system comes complete with the primary pump mounted underneath the water heaters which allows the tank(s) to be very close to the heat source.

You may have a horizontal tank with your system and this is installed in exactly the same way as a standard vertical tank. Each port on the tank is suitably marked to identify the cold inlet, hot outlet and return outlet from the heat source. Refer to page 26 for details about the horizontal tank

External systems are provided with a weather cover and it is very important to mount this over the primary pump(s) to protect the electrical box from being exposed to wet weather.

You will note that some systems have a single primary pump, and some have dual primary pumps. This is dependant on the water heater and whether redundancy of the primary pump has been specifically requested. The system controller will be factory set to control the primary pumps to alternate every 12 hours (for redundancy purposes) or to work in unison (to suit certain water heaters). The system controller is mounted underneath one of the heat source modules and this module should be installed closest to the tank(s).

Ensure primary pump(s) are plugged into the controller and the controller is plugged into an available Socket Outlet. Socket Outlets will need to be provided to match the product you are installing. If you have a Demand Duo then Socket Outlets will need to be provided for all water heaters and controllers. If you have a Demand Duo PLUS then only one Socket Outlet per row of heaters will need to be provided.

Once you have completed the assembly of the system you are ready to connect it up to the building plumbing. **DO NOT** turn any power onto the system until you are at the commissioning stage. Refer to commissioning instructions and log as the back of this manual. Refer to Figure 3 to Figure 6 for assembly instructions.

**Figure 3. Demand Duo**

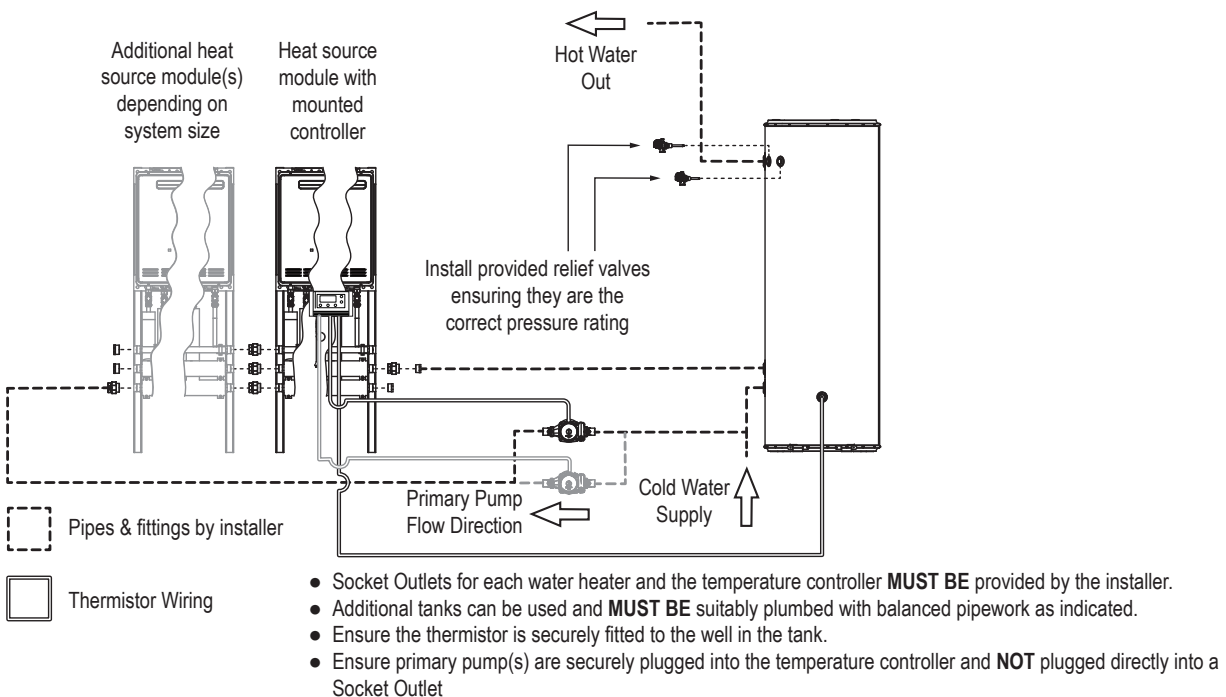

Figure 4. Demand Duo (Additional Tank)

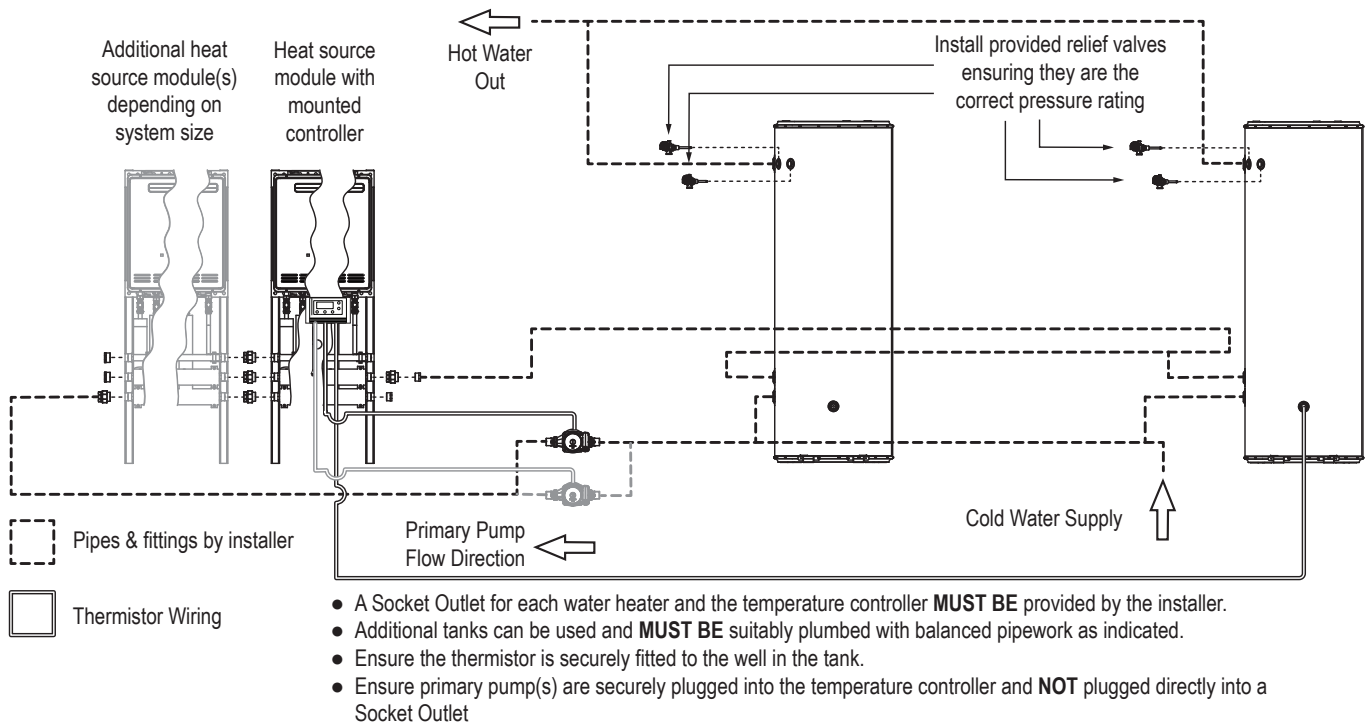
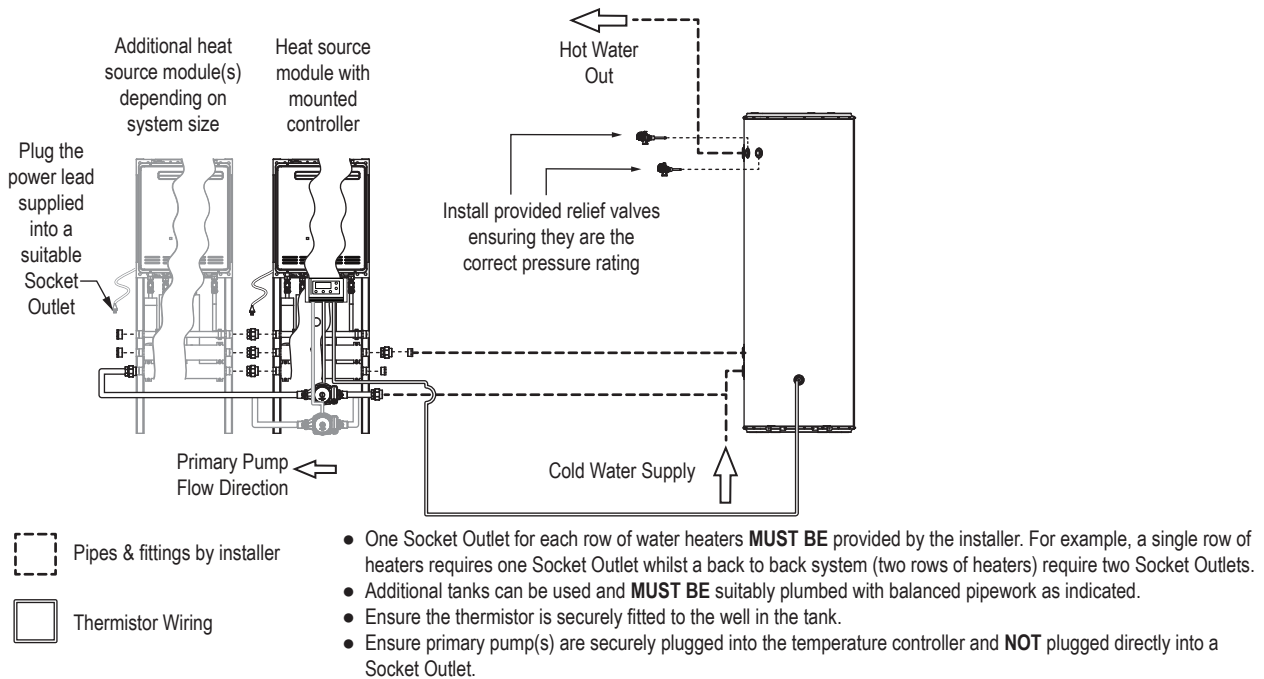
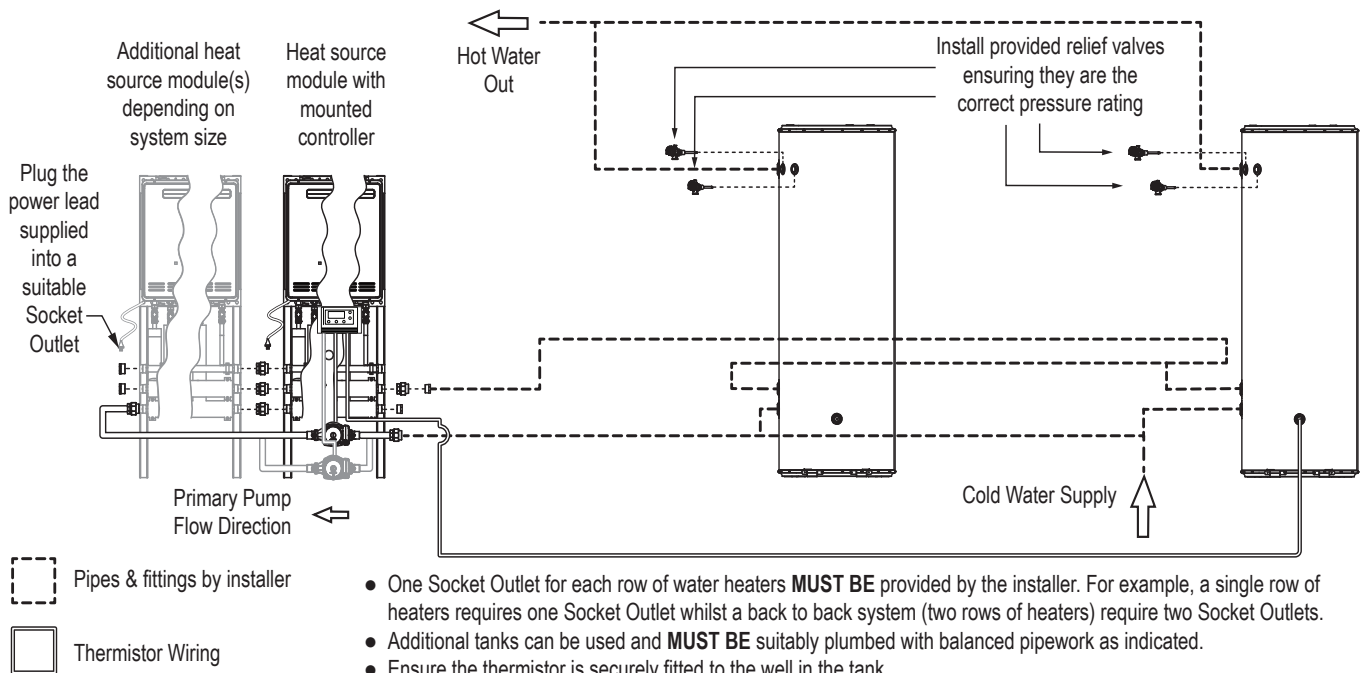

Figure 5. Demand Duo PLUS



**Figure 6. Demand Duo PLUS (Additional Tank)**



- One Socket Outlet for each row of water heaters **MUST BE** provided by the installer. For example, a single row of heaters requires one Socket Outlet whilst a back to back system (two rows of heaters) require two Socket Outlets.
- Additional tanks can be used and **MUST BE** suitably plumbed with balanced pipework as indicated.
- Ensure the thermistor is securely fitted to the well in the tank.
- Ensure the primary pump(s) are securely plugged into the temperature controller and **NOT** plugged directly into a Socket Outlet.

1 x PTR25-850 (132kW) Or  
2 x PTR20/850 (46 kW)

## SPECIFICATIONS

### DD1 Models, Drawing and Specifications (Stainless Steel)

All Dimensions are (mm)								
DD Model	PTR Inclusions	Primary pump	MJ Rating (HD Water Heater)	Total System Weight (kg)	Fittings			
					Hot	Cold	PTR	Gas
DD1 28e/250 ext	2 * HT 575 (92 kW)	UPS20 - 60N	210	110	RP1 1/4" (32mm)	*RP1 1/4" (32mm)	RP1" (25mm)	RP 3/4" (20mm)
DD1 C32e/250 ext	2 * HT 575 (92 kW)	<del>UPS32</del> 100N	209	125	RP1 1/4" (32mm)	*RP1 1/4" (32mm)	RP1" (25mm)	RP 3/4" (20mm)
DD1 28e/315 ext	2 * HT 575 (92 kW)	UPS20 - 60N	210	120	RP1 1/4" (32mm)	RP1 1/4" (32mm)	RP1" (25mm)	RP 3/4" (20mm)
DD1 C32e/315 ext	2 * HT 575 (92 kW)	<del>UPS32</del> 100N	<del>209</del> <sup>125N</sup>	135	RP1 1/4" (32mm)	RP1 1/4" (32mm)	RP1" (25mm)	RP 3/4" (20mm)
DD1 28i/250 int	2 * HT 575 (92 kW)	UPS20 - 60N	210	110	RP1 1/4" (32mm)	*RP1 1/4" (32mm)	RP1" (25mm)	RP 3/4" (20mm)
DD1 28i/315 int	2 * HT 575 (92 kW)	UPS20 - 60N	210	120	RP1 1/4" (32mm)	RP1 1/4" (32mm)	RP1" (25mm)	RP 3/4" (20mm)
DD1 32e/250 ext	2 * HT 575 (92 kW)	UPS25 - 80N	250	120	RP1 1/4" (32mm)	*RP1 1/4" (32mm)	RP1" (25mm)	RP 3/4" (20mm)
DD1 250e/250 ext	2 * HT 575 (92 kW)	UPS25 - 80N	250	120	RP1 1/4" (32mm)	*RP1 1/4" (32mm)	RP1" (25mm)	RP 3/4" (20mm)
DD1 C32i/315 int	2 * HT 575 (92 kW)	<del>UPS32</del> 100N	209	135	RP1 1/4" (32mm)	*RP1 1/4" (32mm)	RP1" (25mm)	RP 3/4" (20mm)
DD1 32e/315 ext	2 * HT 575 (92 kW)	UPS25 - 80N	250	130	RP1 1/4" (32mm)	RP1 1/4" (32mm)	RP1" (25mm)	RP 3/4" (20mm)
DD1 250e/315 ext	2 * HT 575 (92 kW)	UPS25 - 80N	250	130	RP1 1/4" (32mm)	RP1 1/4" (32mm)	RP1" (25mm)	RP 3/4" (20mm)
DD 250	1 * HT 575 (46 kW)	N/A	N/A	73	RP1 1/4" (32mm)	*RP1 1/4" (32mm)	RP1" (25mm)	N/A
DD 315	1 * HT 575 (46 kW)	N/A	N/A	88	RP1 1/4" (32mm)	RP1 1/4" (32mm)	RP1" (25mm)	N/A
DD 250-50	1 * HT 575 (46 kW)	N/A	N/A	75	RP2" (50mm)	RP2" (50mm)	RP1" (25mm)	N/A
DD 315-50	1 * HT 575 (46 kW)	N/A	N/A	90	RP2" (50mm)	RP2" (50mm)	RP1" (25mm)	N/A

ALL HT 575 PTR valves are rated at 850 kPa - RA Part No. 11004782



DD1 250L only tank supplied with 32mm brass plug to plug one of the unused cold inlet ports.

Add -DD420-50

1 x PTR25-1000 (132kW) Or  
2 x PTR20/1000 (46 kW)

Type text here

**SPECIFICATIONS**

**DD1 Models, Drawing and Specifications (Vitreous Enamel)**

All Dimensions are (mm)								
DD Model	PTR Inclusions	Primary pump	MJ Rating (HD Water Heater)	Total System Weight (kg)	Fittings			
					Hot	Cold	PTR	Gas
DD1 28e/ 270V ext	1 x PTR25-1000 (132kW)	UPS20 - 60N	210	141	RP2" (50mm)	RP2" (50mm)	RP1" (25mm)	RP 3/4" (20mm)
DD1 28e/ 330V ext	1 x PTR25-1000 (132kW)	UPS20 - 60N	210	155	RP2" (50mm)	RP2" (50mm)	RP1" (25mm)	RP 3/4" (20mm)
DD1 28e/ 440V ext	1 x PTR25-1000 (132kW)	UPS20 - 60N	210	170	RP2" (50mm)	RP2" (50mm)	RP1" (25mm)	RP 3/4" (20mm)
DD1 28i/ 270V int	1 x PTR25-1000 (132kW)	UPS20 - 60N	210	141	RP2" (50mm)	RP2" (50mm)	RP1" (25mm)	RP 3/4" (20mm)
DD1 28i/ 330V int	1 x PTR25-1000 (132kW)	UPS20 - 60N	210	155	RP2" (50mm)	RP2" (50mm)	RP1" (25mm)	RP 3/4" (20mm)
DD1 28i/ 440V int	1 x PTR25-1000 (132kW)	UPS20 - 60N	210	170	RP2" (50mm)	RP2" (50mm)	RP1" (25mm)	RP 3/4" (20mm)
DD1 C32e/ 270V ext	1 x PTR25-1000 (132kW)	<del>UPS32 - 100N</del> UPM25 - 125N	209	156	RP2" (50mm)	RP2" (50mm)	RP1" (25mm)	RP 3/4" (20mm)
DD1 C32e/ 330V ext	1 x PTR25-1000 (132kW)	<del>UPS32 - 100N</del>	209	245	RP2" (50mm)	RP2" (50mm)	RP1" (25mm)	RP 3/4" (20mm)
DD1 C32e/ 440V ext	1 x PTR25-1000 (132kW)	<del>UPS32 - 100N</del>	209	260	RP2" (50mm)	RP2" (50mm)	RP1" (25mm)	RP 3/4" (20mm)
DD1 C32i/ 270V int	1 x PTR25-1000 (132kW)	<del>UPS32 - 100N</del>	209	156	RP2" (50mm)	RP2" (50mm)	RP1" (25mm)	RP 3/4" (20mm)
DD1 C32i/ 330V int	1 x PTR25-1000 (132kW)	<del>UPS32 - 100N</del>	209	245	RP2" (50mm)	RP2" (50mm)	RP1" (25mm)	RP 3/4" (20mm)
DD1 C32i/ 440V int	1 x PTR25-1000 (132kW)	<del>UPS32 - 100N</del>	209	260	RP2" (50mm)	RP2" (50mm)	RP1" (25mm)	RP 3/4" (20mm)
DD1 32e/ 270V ext	1 x PTR25-1000 (132kW)	UPS25 - 80N	250	150	RP2" (50mm)	RP2" (50mm)	RP1" (25mm)	RP 3/4" (20mm)
DD1 32e/ 330V ext	1 x PTR25-1000 (132kW)	UPS25 - 80N	250	240	RP2" (50mm)	RP2" (50mm)	RP1" (25mm)	RP 3/4" (20mm)
DD1 32e/ 440V ext	1 x PTR25-1000 (132kW)	UPS25 - 80N	250	255	RP2" (50mm)	RP2" (50mm)	RP1" (25mm)	RP 3/4" (20mm)
DD270V-50	1*PTR20/1000 (46 kW)	N/A	N/A	84	RP2" (50mm)	RP2" (50mm)	RP1" (25mm)	N/A
DD330V-50	1*PTR20/1000 (46 kW)	N/A	N/A	98	RP2" (50mm)	RP2" (50mm)	RP1" (25mm)	N/A
DD440V-50	1*PTR20/1000 (46 kW)	N/A	N/A	122	RP2" (50mm)	RP2" (50mm)	RP1" (25mm)	N/A

ALL PTR25-1000 and PTR20/1000 PTR valves are rated at 1000 kPa.

**DD1 28e / 250L, 315L Stainless Steel Tanks**

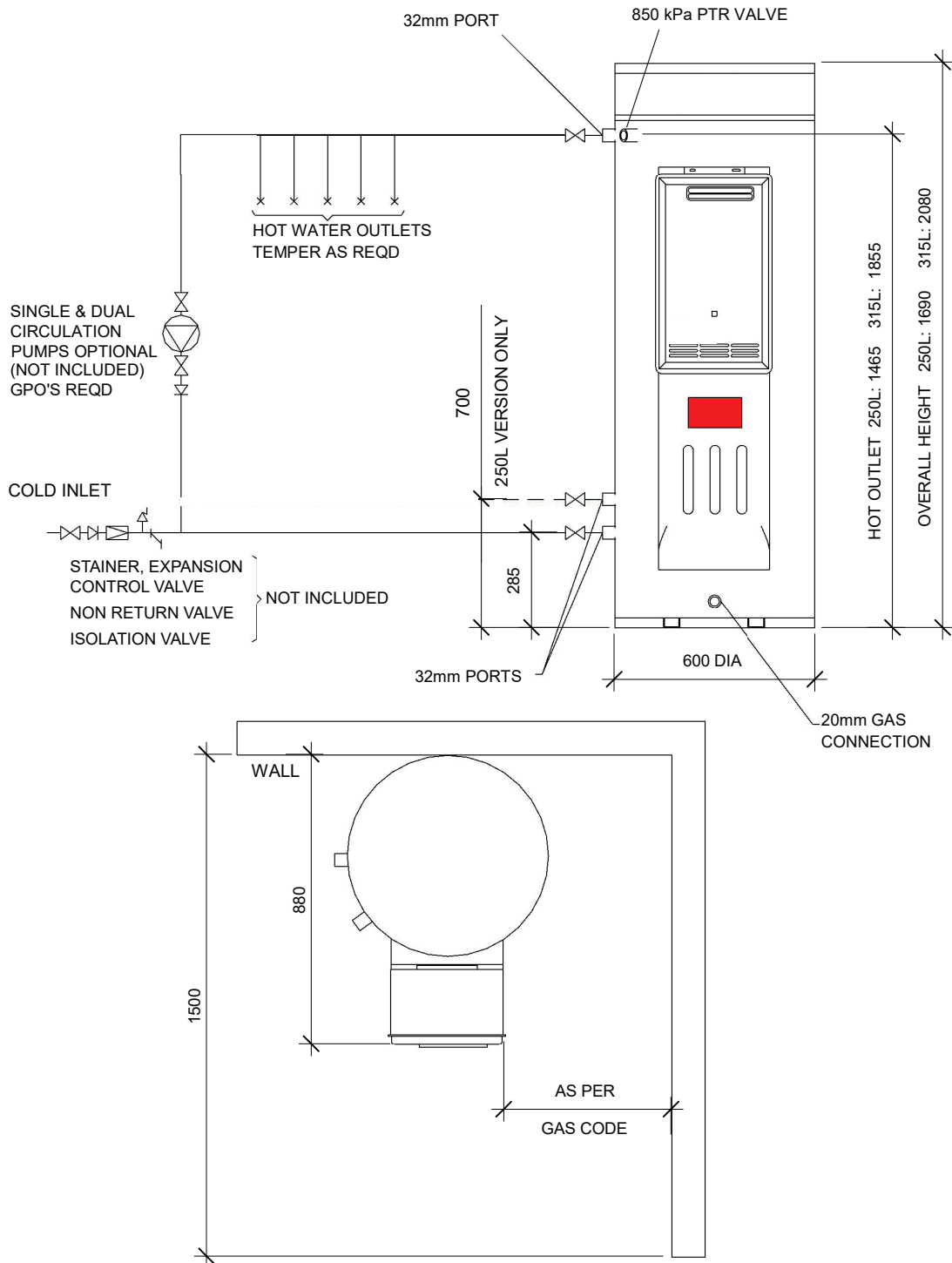

**PLUG UNUSED COLD INLET PORT WITH BRASS PLUG 32MM SUPPLIED WITH TANK.**

**SPECIFICATIONS**

**DD1 28e / 270L, 330L & 440L Vitreous Enamel tanks**

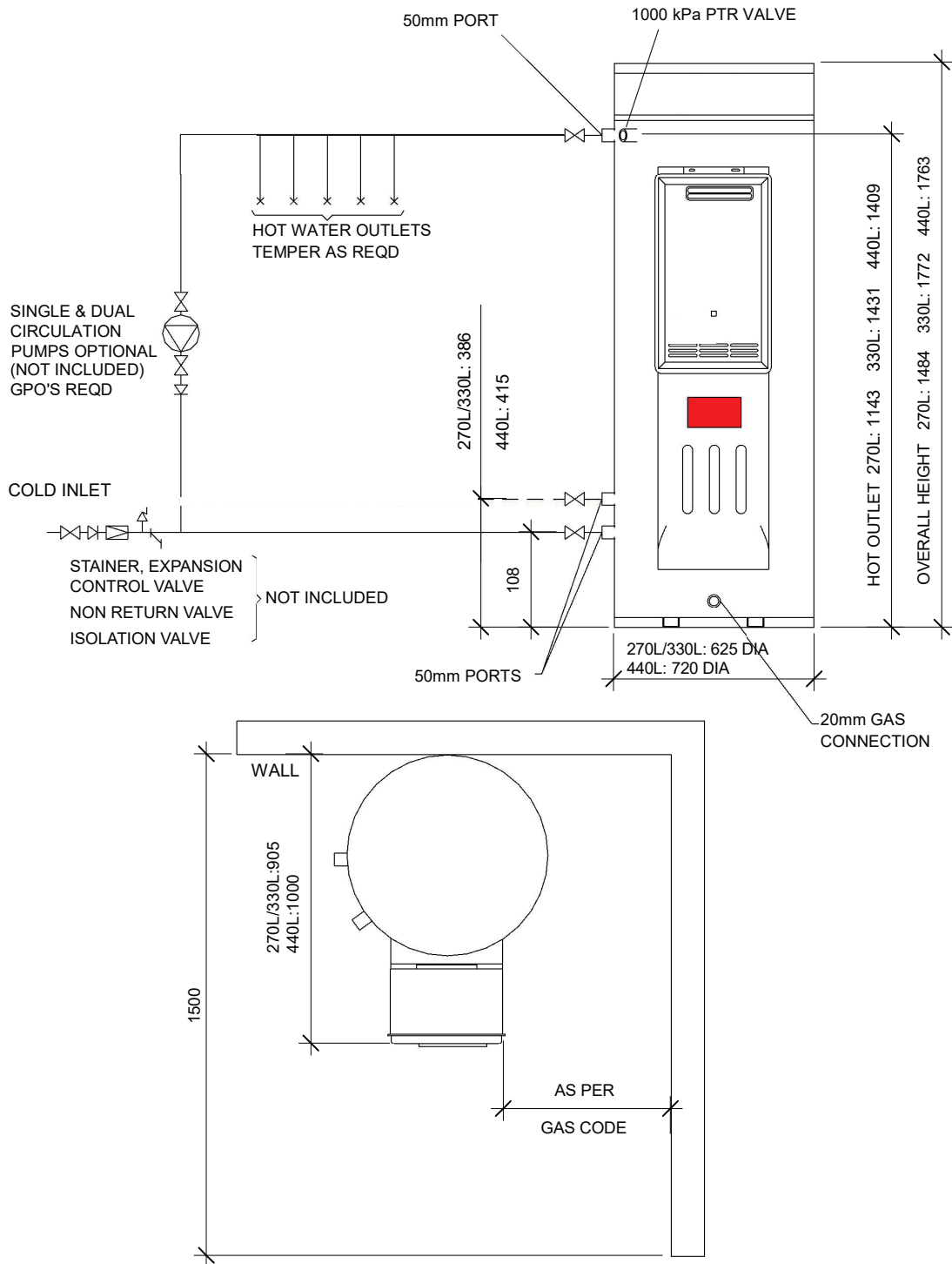

**PLUG UNUSED PORTS WITH BRASS PLUGS SUPPLIED WITH TANK.**

**DD1 28i / 250L, 315L Stainless Steel Tanks**

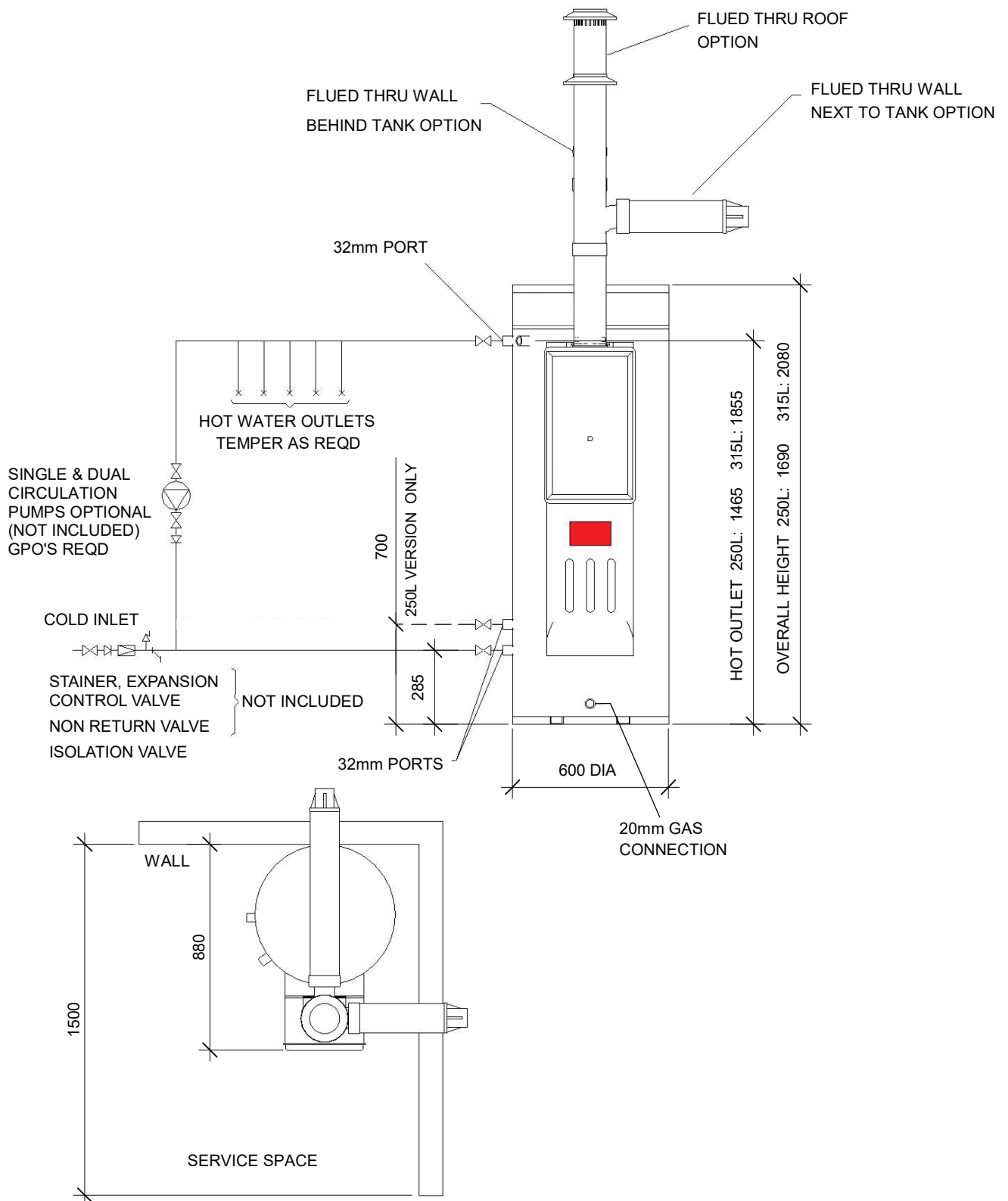

**NOTE** PLUG UNUSED COLD INLET PORT WITH BRASS PLUG 32MM SUPPLIED WITH TANK.

**SPECIFICATIONS**

**DD1 28i / 270L, 330L & 440L Vitreous Enamel Tanks**

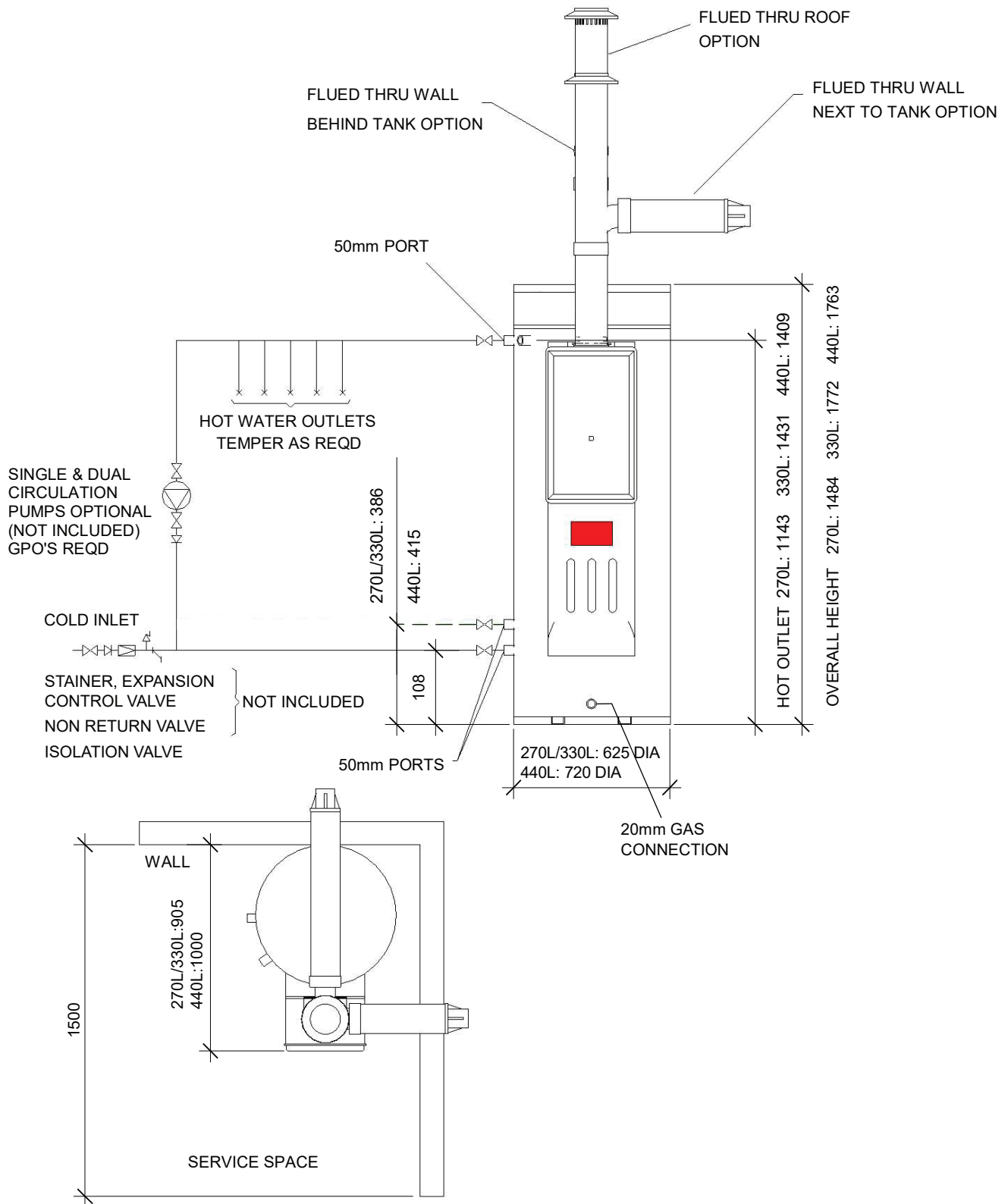

**NOTE** PLUG UNUSED PORTS WITH BRASS PLUGS SUPPLIED WITH TANK.

**DD1 32e / 250L & 315L Stainless Steel Tanks**

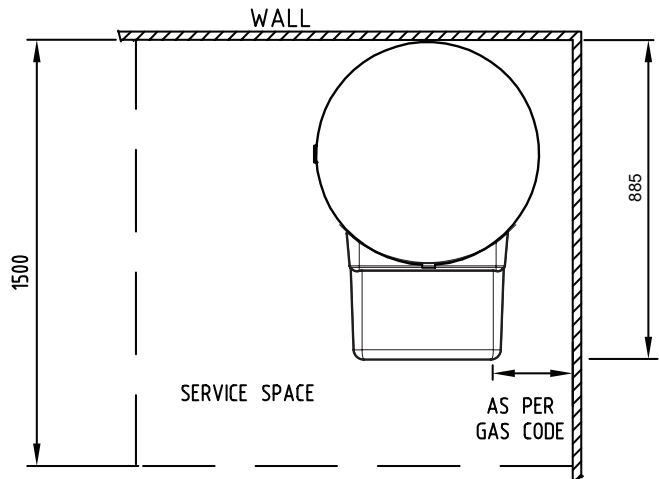
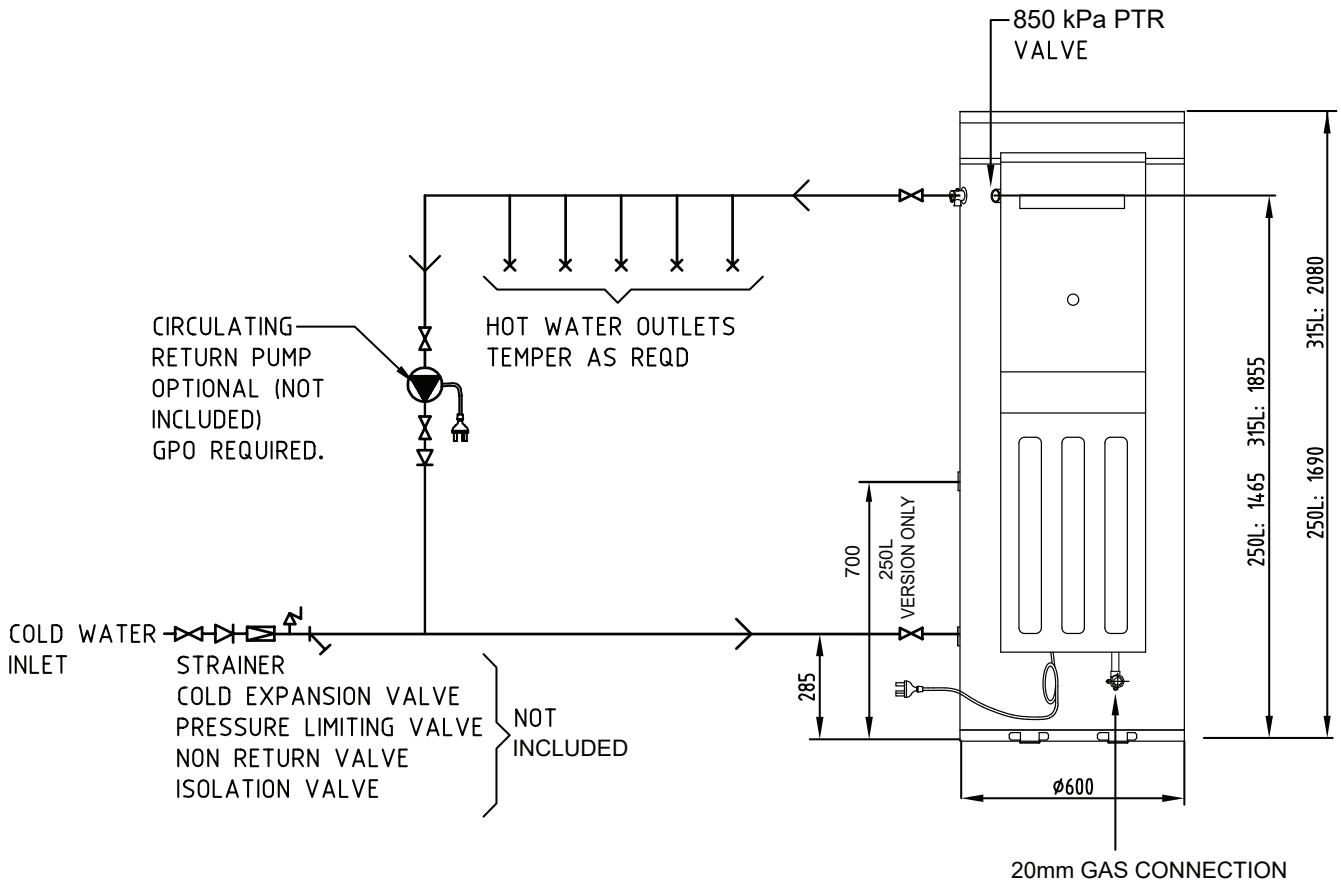

**NOTE** **PLUG UNUSED COLD INLET PORT WITH BRASS PLUG 32MM SUPPLIED WITH TANK.**

**SPECIFICATIONS**

**DD1 32e / 270L, 330L & 440L Vitreous Enamel Tanks**

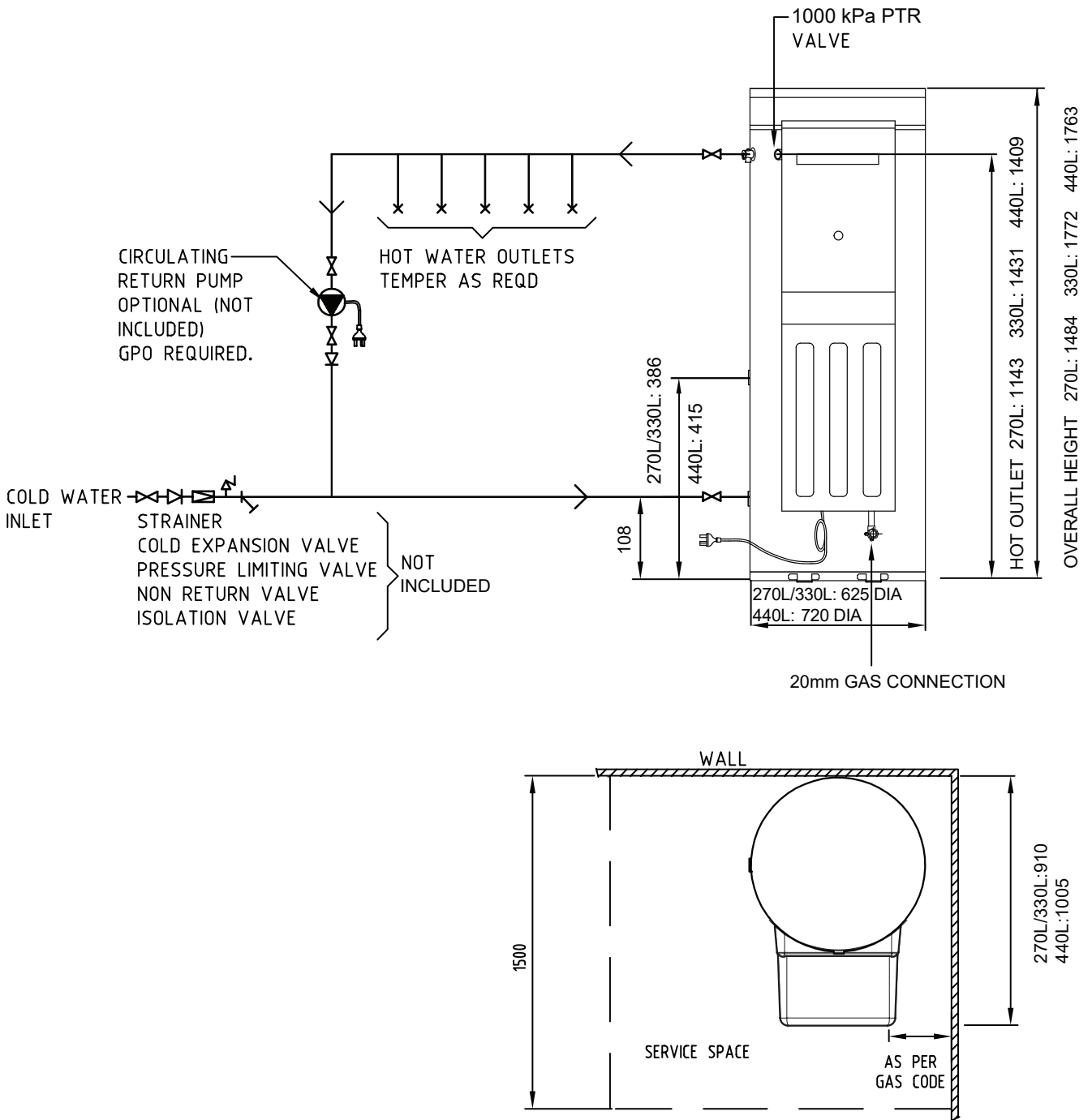

**NOTE** PLUG UNUSED PORTS WITH BRASS PLUGS SUPPLIED WITH TANK.

**DD1 C32e / 250L & 315L Stainless Steel Tanks**

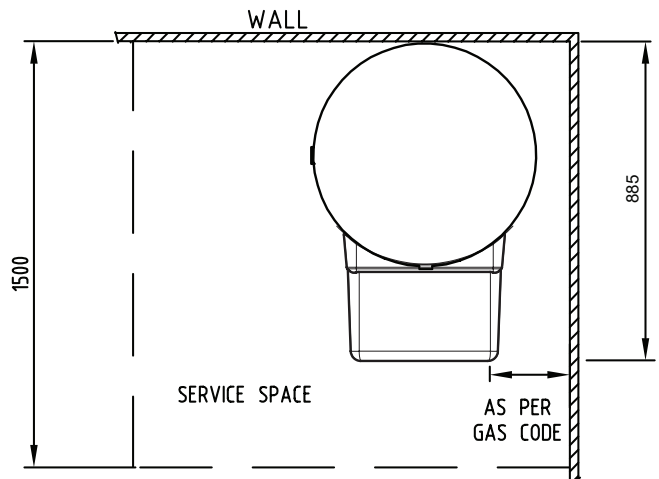
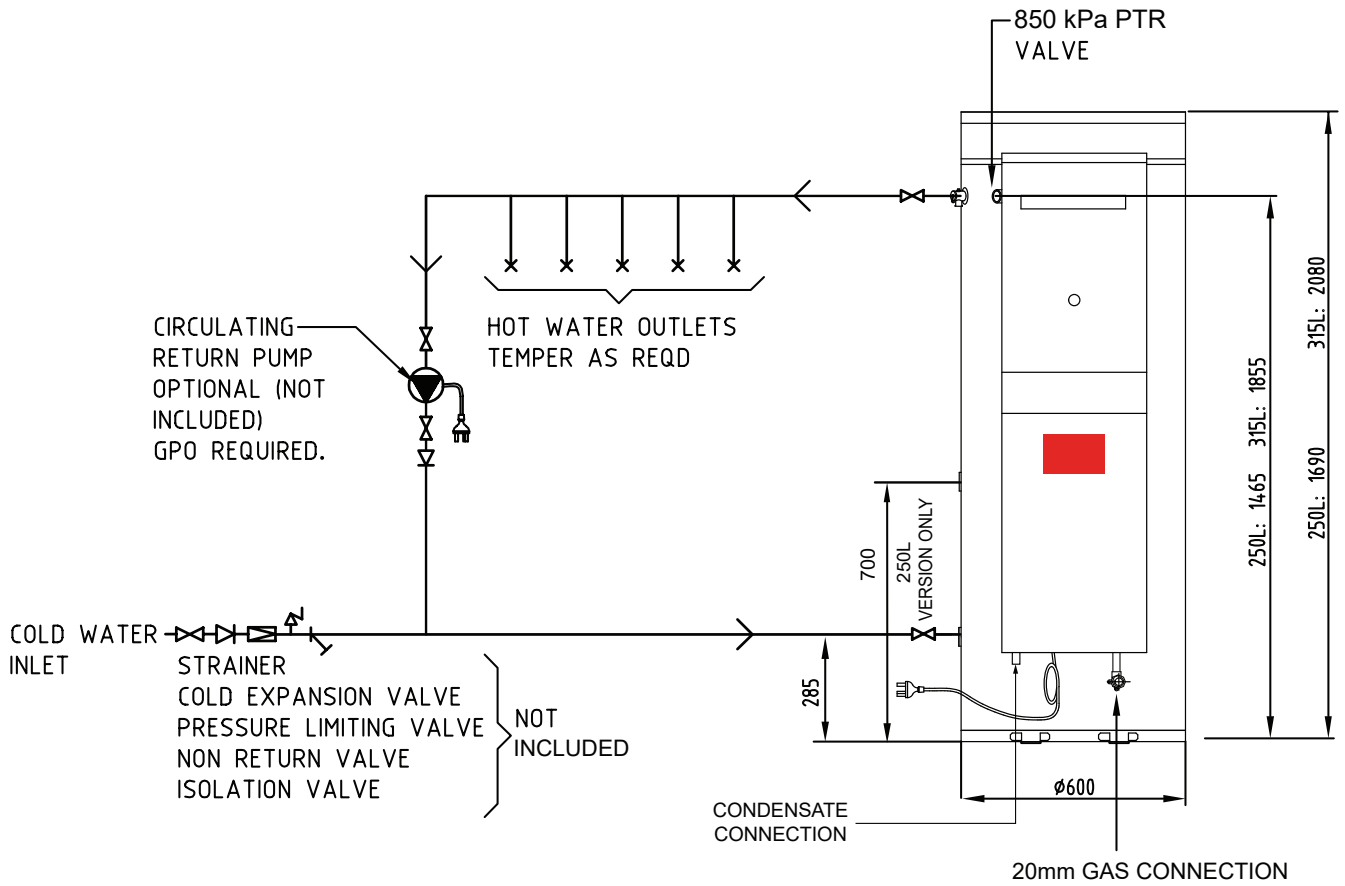

**PLUG UNUSED COLD INLET PORT WITH BRASS PLUG 32MM SUPPLIED WITH TANK.**

**SPECIFICATIONS**

**DD1 C32e / 270L, 330L & 440L Vitreous Enamel Tanks**

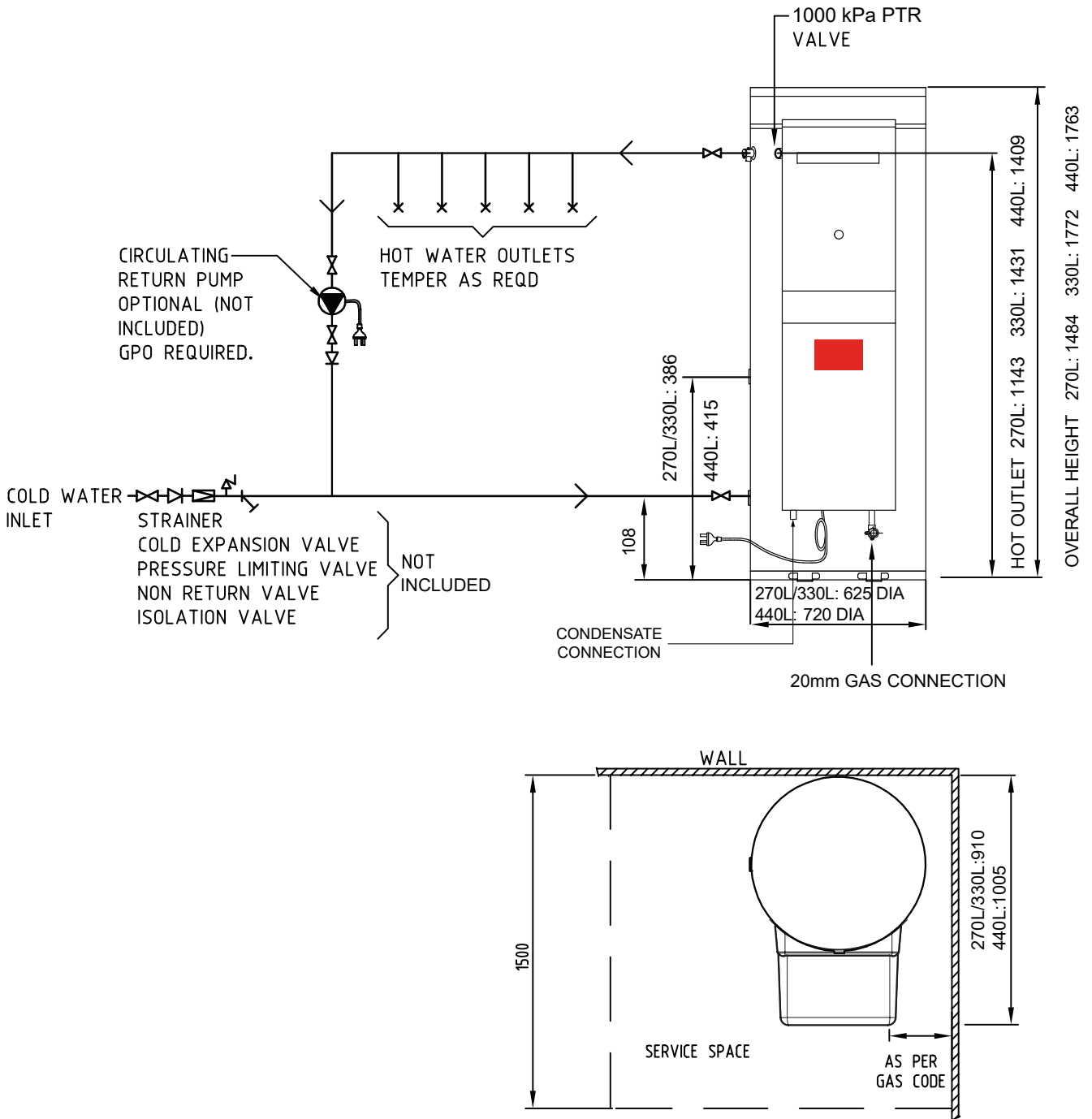

**PLUG UNUSED PORTS WITH BRASS PLUGS SUPPLIED WITH TANK.**

**DD1 C32i / 250L & 315L Stainless Steel Tanks**

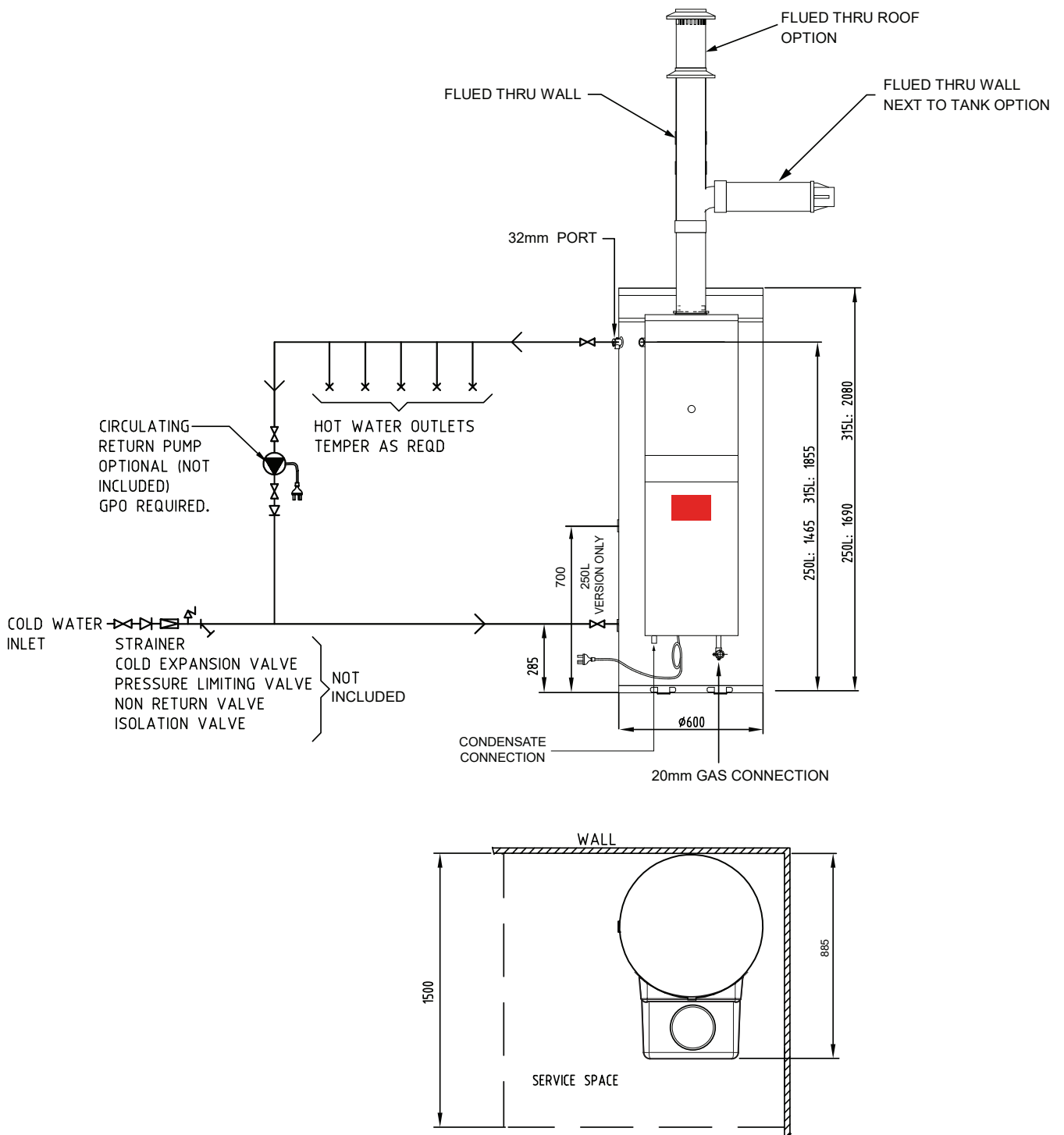

 **NOTE** **PLUG UNUSED COLD INLET PORT WITH BRASS PLUG 32MM SUPPLIED WITH TANK.**

## DD1 C32i / 270L, 330L & 440L Vitreous Enamel Tanks

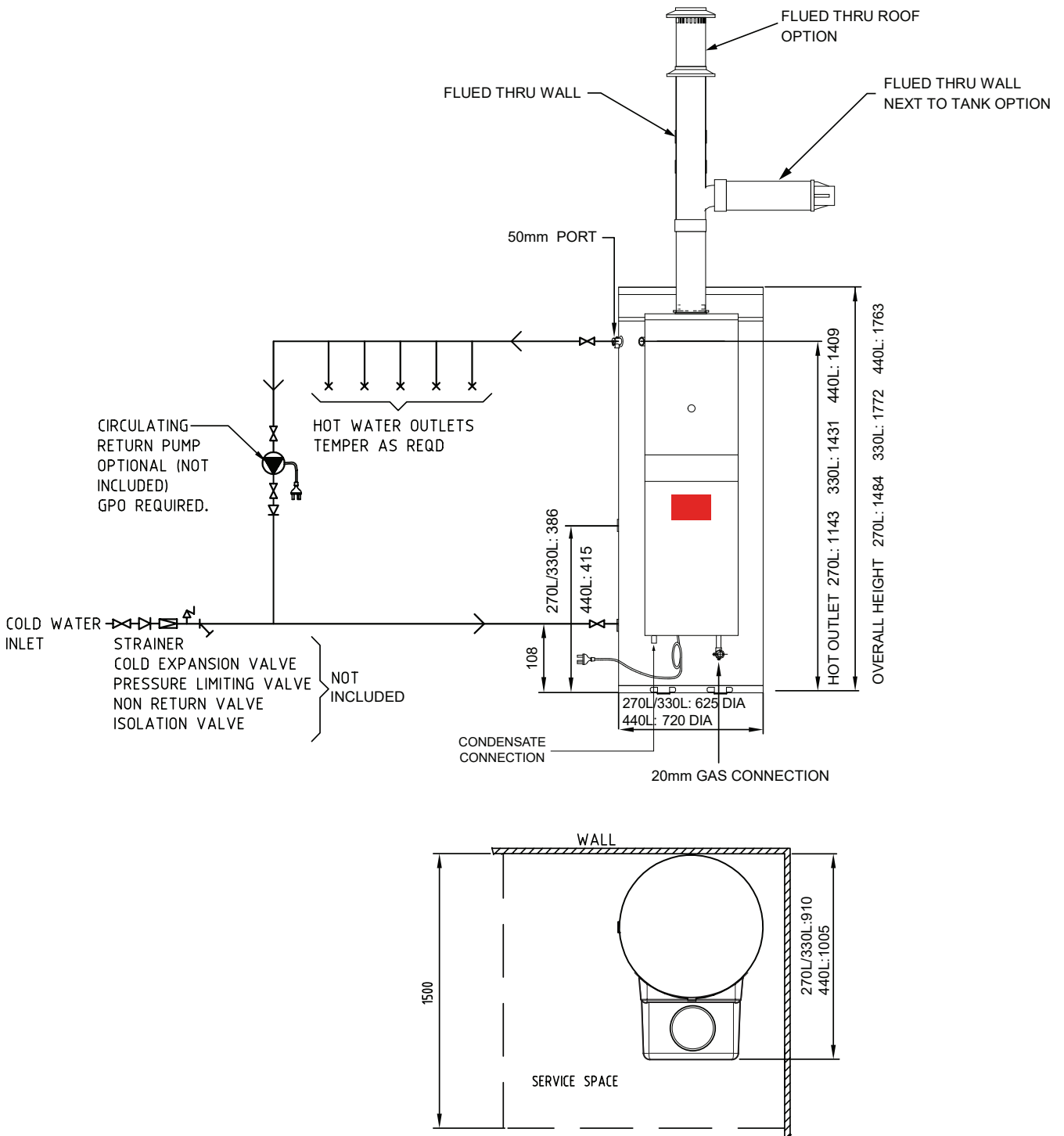

**NOTE** PLUG UNUSED PORTS WITH BRASS PLUGS SUPPLIED WITH TANK.

## DD Stainless Steel Tank Specifications

Note: All dimensions in millimetres	Vertical					Horizontal
	DD250	DD250-50	DD315	DD315-50	DD420-50	SH33000G11A
<b>A</b>	1690	1690	2080	2080	1840	2080
<b>B</b>	1465	1465	1855	1855	1559	1855
<b>C</b>	285	285	285	285	262	285
<b>D</b>	385	385	385 <td 385	362	385	
<b>E (Diameter)</b>	600	600	600	600	710	600
<b>Hot/cold/return port</b>	DN32	DN50	DN32	DN50	DN50	DN50
<b>PTR port (s)</b>	DN25	DN25	DN25	DN25	DN25	DN25
<b>Sensor well port</b>	DN20	DN20	DN20	DN20	DN20	DN20

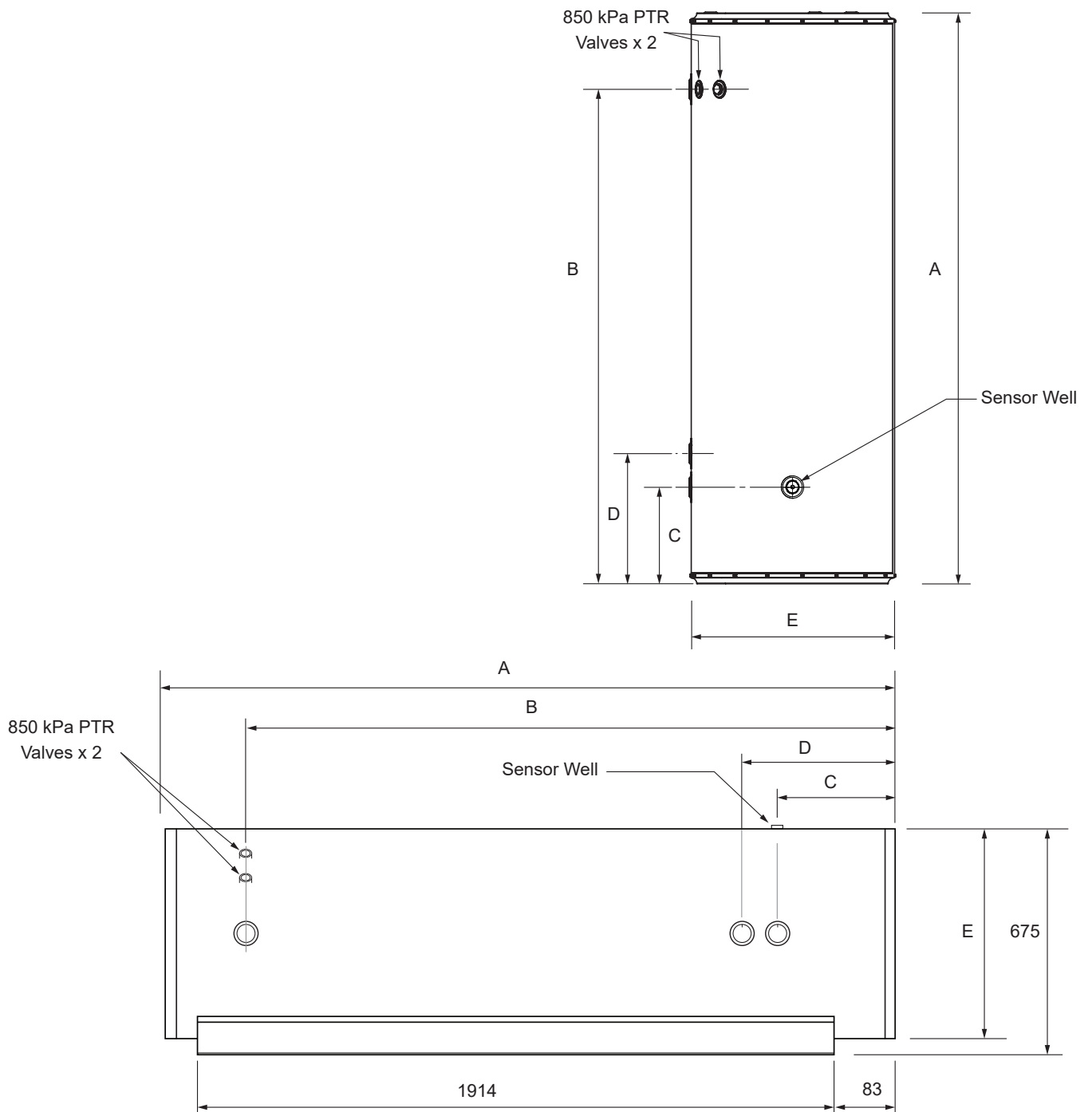

## DD Vitreous Enamel tank Specifications

Note: All dimensions in millimetres	Vertical		
	DD270V-50	DD330V-50	DD440V-50
A	1484	1772	1763
B	1143	1431	1409
C	108	108	108
D	386	386	415
E (Diameter)	625	625	720
F	286	286	286
Hot/cold/return port	50	50	50
PTR port (s)	25	25	25
Return/Outlet/Sensor well port	20	20	20

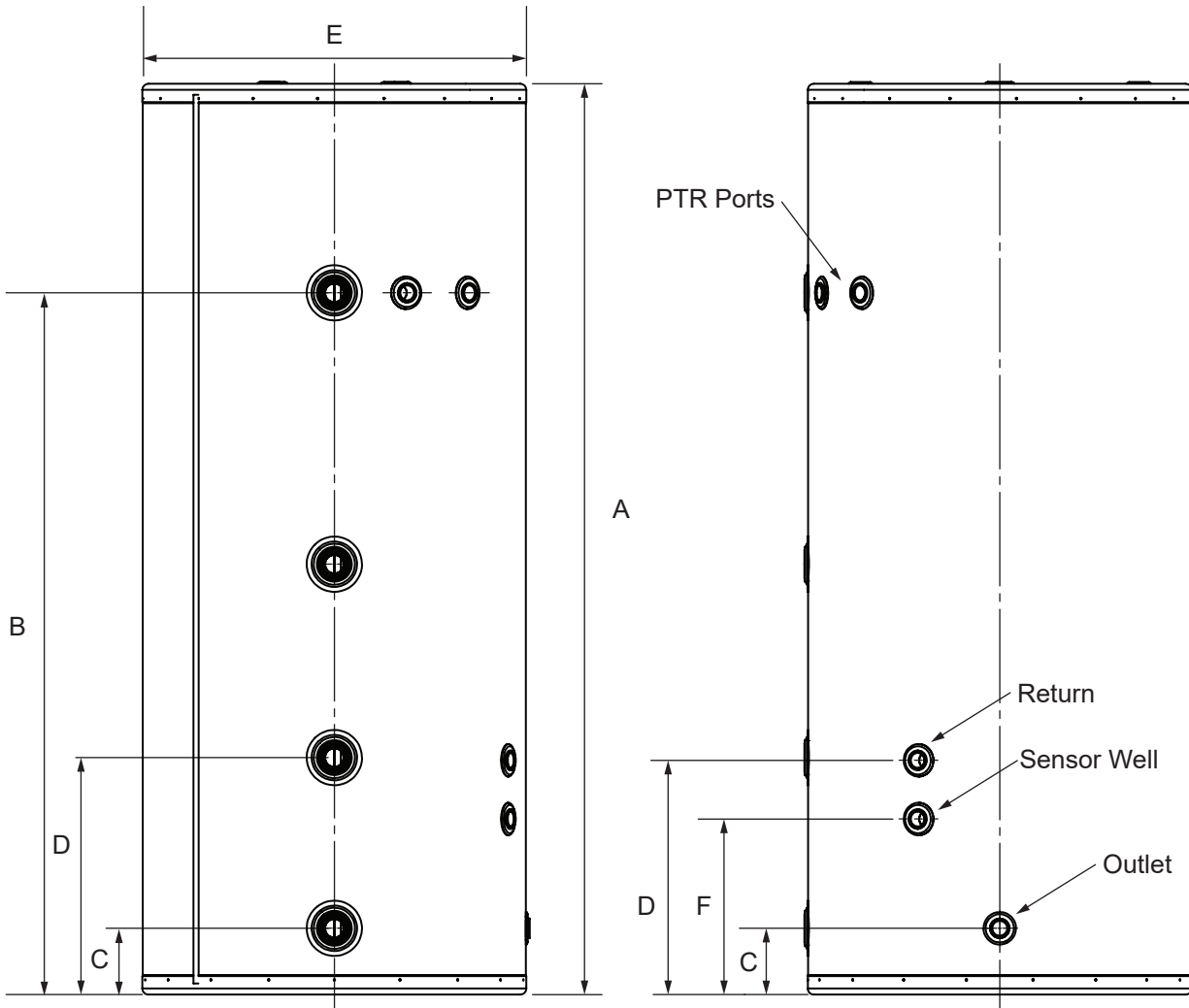

## Demand Duo with multiple gas water heaters (250L, 315 & 420L Stainless Steel Tanks) – Specifications

(All dimensions are in mm)													
DD model	A	B	C 250L 315L	C 420L	E per tank	PTR Inclusions	Primary pump	Total system weight - 250L tank (kgs)	Total system weight - 315L tank (kgs)	Total system weight - 420L tank (kgs)	Number of tanks		
DD2 28 Ext/Intl	375	750	1850	1960	600  710*	PTR25/850 (132kW) + PTR20/850 (46kW)	UPS25-80N	120	132	145	1		
DD3 28 Ext/Intl		1125	2225	2335					150	162	175	1	
DD4 28 Ext/Intl		1500	2600	2710				2 x PTR25/850 (132kW) + PTR20/850 (46kW)		180	192	205	1
DD5 28 Ext/Intl		1875	2975	3085				UPM25- 125N	210	222	235	1	
DD6 28 Ext/Intl		2250	3350	3460			3 x PTR25/850 (132kW) + 1 PTR20/850 (46kW)	UPS32- 100N	240	252	265	1	
DD7 28 Ext/Intl		2625	3725	3835						270	282	295	1
DD8 28 Ext/Intl		3000	4100	4210			4 x PTR25/850 (132kW) + 2 X PTR20/850 (46kW)			360	384	410	2
DD9 28 Ext/Intl		3375	4475	4585				2 x UPS32- 100N	390	414	440	2	
DD10 28 Ext/Intl		3750	4850	4960					450	444	500	2	
DD2 C32/32 Ext/Intl		500	1000	2100		2210	600  710*	PTR25/850 (132kW) + PTR20/850 (46kW)	UPS32- 100N	143	155	168	1
DD3 C32/32 Ext/Intl	1500		2600	2710				183		195	208	1	
DD4 C32/32 Ext/Intl	2000		3100	3210		2 x PTR25/850 (132kW) + PTR20/850 (46kW)		<del>2 x UPS32- 100N</del>	228	240	253	1	
DD5 C32/32 Ext/Intl	2500		3600	3710					268	280	293	1	
DD6 C32/32 Ext/Intl	3000		4100	4210		3 x PTR25/850 (132kW) + 1 PTR20/850 (46kW)		2 x UPM25- 125N	308	320	333	1	
DD7 C32/32 Ext/Intl	3500		4600	4710				2 x UPS32- 100N	348	360	373	1	
DD8 C32/32 Ext/Intl	4000		5100	5210				1 x CM10-1	448	472	473	2	
DD9 C32/32 Ext/Intl	4500		5600	5710		4 x PTR25/850 (132kW) + 2 X PTR20/850 (46kW)				488	512	513	2
DD10 C32/32 Ext/Intl	5000		6100	6210						528	552	556	2

**\* Dimension for systems with 420L tank**

Tank Model (L)	F	G	H	I	Dry weight (kg)	Wet weight (kg)
250	285	385	1465	1690	60	310
315	285	385	1855	2080	72	385
420	262	362	1559	1840	85	505

HD Model	J	K	L	M	MJ Rating
HD28e	340	440	540	1500	210
HD28i					210
HD32e					250
HD210e					209
HD210i					209
HDC32					209

Type text here

## Demand Duo with multiple gas water heaters (270L, 330 & 440L Vitreous Enamel tanks) – Specifications

(All dimensions are in mm)										
DD model	A	B	C	E per tank	PTR Inclusions	Primary pump	Total system weight - 270L tank (kg)	Total system weight - 330L tank (kg)	Total system weight - 440L tank (kg)	Number of tanks
DD2 28 Ext/Intl	375	750	1950	Refer table below	PTR25/1000 (132kW) + PTR20/1000 (46kW)	UPS25-80N	151	167	180	1
DD3 28 Ext/Intl		1125	2325				181	199	210	1
DD4 28 Ext/Intl		1500	2700				211	227	240	1
DD5 28 Ext/Intl		1875	3075		2 x PTR25/1000 (132kW) + PTR20/1000 (46kW)	UPS32-100N	241	257	270	1
DD6 28 Ext/Intl		2250	3450		3 x PTR25/1000 (132kW) + 1 PTR20/1000 (46kW)		271	287	300	1
DD7 28 Ext/Intl		2625	3825		301		317	330	1	
DD8 28 Ext/Intl		3000	4200		4 x PTR25/1000 (132kW) + 2 X PTR20/1000 (46kW)		391	419	432	2
DD9 28 Ext/Intl		3375	4575		421		449	462	2	
DD10 28 Ext/Intl		3750	4950		481		479	492	2	
DD2 C32/32 Ext/Intl		500	1000		2200		Refer table below	PTR25/1000 (132kW) + PTR20/1000 (46kW)	UPS32-100N	174
DD3 C32/32 Ext/Intl	1500		2700	214	230	243				1
DD4 C32/32 Ext/Intl	2000		3200	2 x PTR25/1000 (132kW) + PTR20/1000 (46kW)	2 x UPS32-100N	259		59	288	1
DD5 C32/32 Ext/Intl	2500		3700	299		315		328	1	
DD6 C32/32 Ext/Intl	3000		4200	3 x PTR25/1000 (132kW) + 1 PTR20/1000 (46kW)		339		355	368	1
DD7 C32/32 Ext/Intl	3500		4700	379	395	408		1		
DD8 C32/32 Ext/Intl	4000		5200	479	507	520		2		
DD9 C32/32 Ext/Intl	4500		5700	519	547	560		2		
DD10 C32/32 Ext/Intl	5000		6200	559	587	600		2		
						4 x PTR25/1000 (132kW) + 2 X PTR20/81000 (46kW)		1 x CM10-1		

Tank Model (L)	E	F	G	H	I	Dry weight (kg)	Wet weight (kg)
270	625	108	386	1143	1484	84	354
330	625	108	386	1431	1772	98	428
440	720	108	415	1409	1763	122	562

HD Model	J	K	L	M	MJ Rating
HD28e	340	440	540	1500	210
HD28i					210
HD32e					250
HD210e					209
HD210i					209
HDC32					209

## Typical installation for Demand Duo

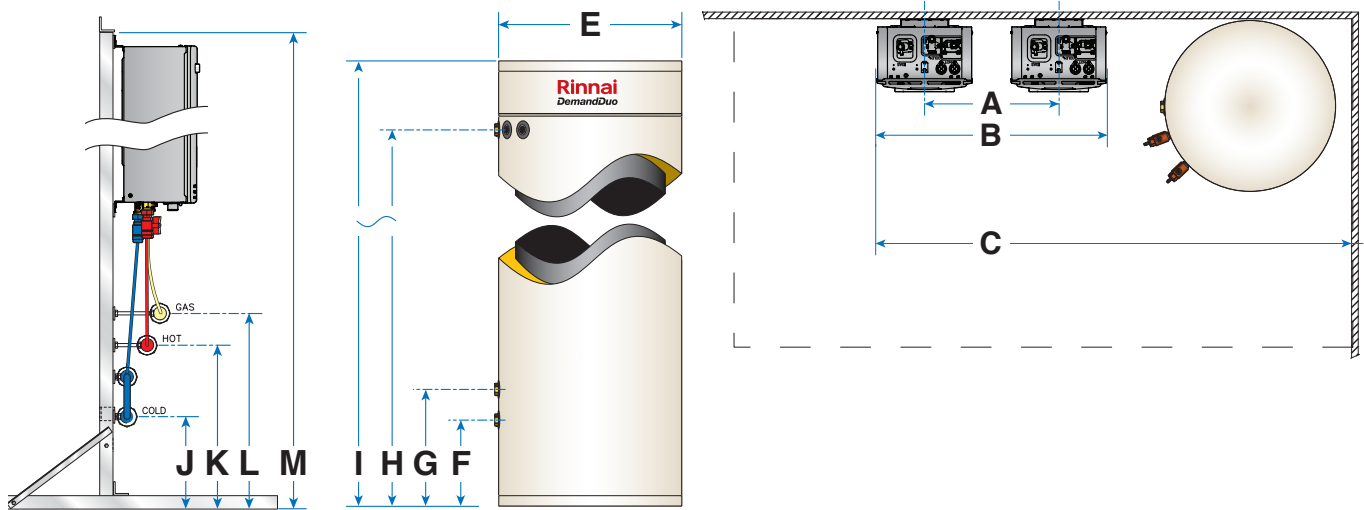
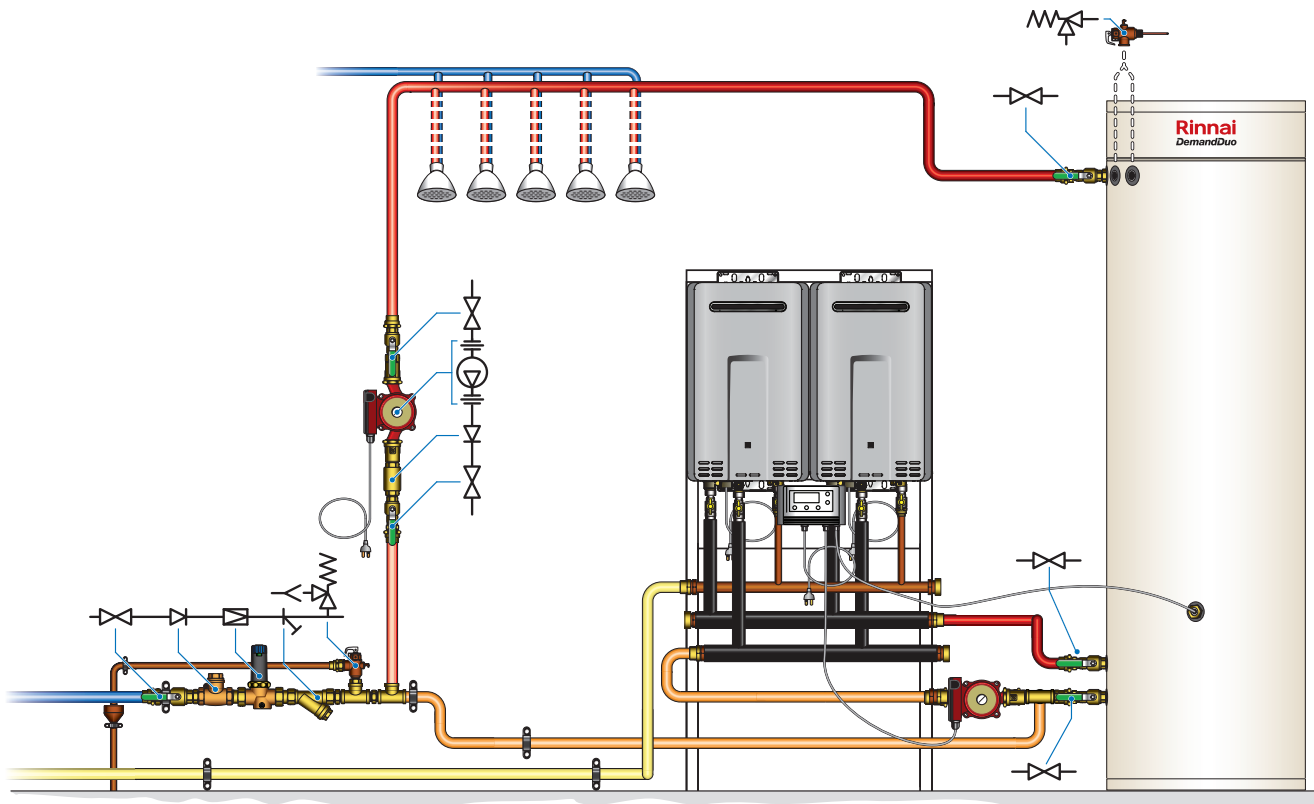

**NOTE** PRIMARY PUMP(S) MUST BE PLUGGED INTO THE CONTROLLER AND NOT AN AVAILABLE SOCKET OUTLET.

## Demand Duo PLUS with multiple gas water heaters (250L, 315 & 420L Stainless Steel Tanks) – Specifications

(All dimensions are in mm)												
DD model	A	B	C 250L 315L	C 420L	E per tank	PTR Inclusions	Primary pump	Total system weight - 250L tank (kg)	Total system weight - 315L tank (kg)	Total system weight - 420L tank (kgs)	Number of tanks	
DD2 28 Ext/Intl	375	750	1850	1960	600	PTR25/850 (132kW) + PTR20/850 (46kW)	UPS25-80N	120	132	145	1	
DD3 28 Ext/Intl		1125	2225	2335				150	162	175	1	
DD4 28 Ext/Intl		1500	2600	2710				180	192	205	1	
DD5 28 Ext/Intl		1875	2975	3085				210	222	235	1	
DD6 28 Ext/Intl		2250	3350	3460	710*	2 x PTR25/850 (132kW) + PTR20/850 (46kW)	UPS32- 100N	240	252	265	1	
DD7 28 Ext/Intl		2625	3725	3835				270	282	295	1	
DD8 28 Ext/Intl		3000	4100	4210				360	384	410	2	
DD9 28 Ext/Intl		3375	4475	4585				390	414	440	2	
DD10 28 Ext/Intl		3750	4850	4960				450	444	500	2	
DD10 28 Ext/Intl		3750	4850	4960				450	444	500	2	
DD2 C32/32 Ext/Intl	500	1000	2100	2210	600	PTR25/850 (132kW) + PTR20/850 (46kW)	UPS32- 100N	143	155	168	1	
DD3 C32/32 Ext/Intl		1500	2600	2710				183	195	208	1	
DD4 C32/32 Ext/Intl		2000	3100	3210				2 x UPS32- 100N	228	240	253	1
DD5 C32/32 Ext/Intl		2500	3600	3710					268	280	293	1
DD6 C32/32 Ext/Intl		3000	4100	4210	710*	3 x PTR25/850 (132kW) + 1 PTR20/850 (46kW)	1 x CM10-1	308	320	333	1	
DD7 C32/32 Ext/Intl		3500	4600	4710				348	360	373	1	
DD8 C32/32 Ext/Intl		4000	5100	5210				448	472	473	2	
DD9 C32/32 Ext/Intl		4500	5600	5710				488	512	513	2	
DD10 C32/32 Ext/Intl		5000	6100	6210				528	552	556	2	
DD10 C32/32 Ext/Intl		5000	6100	6210				528	552	556	2	

**\* Dimension for systems with 420L tank**

Tank Model (L)	F	G	H	I	Dry weight (kg)	Wet weight (kg)
250	285	385	1465	1690	60	310
315	285	385	1855	2080	72	385
420	262	362	1559	1840	85	505

HD Model	J	K	L	M	MJ Rating
HD28e	340	440	540	1500	210
HD28i					210
HD32e					250
HD210e					209
HD210i					209
HDC32					209

**Demand Duo PLUS with multiple gas water heaters (270L, 330 & 440L Vitreous Enamel tanks) – Specifications**

<b>(All dimensions are in mm)</b>										
<b>DD model</b>	<b>A</b>	<b>B</b>	<b>C</b>	<b>E per tank</b>	<b>PTR Inclusions</b>	<b>Primary pump</b>	<b>Total system weight - 270L tank (kg)</b>	<b>Total system weight - 330L tank (kg)</b>	<b>Total system weight - 440L tank (kg)</b>	<b>Number of tanks</b>
DD2 28 Ext/Intl	375	750	1950	Refer table below	PTR25/1000 (132kW) + PTR20/1000 (46kW)	UPS25-80N	151	167	180	1
DD3 28 Ext/Intl		1125	2325				181	199	210	1
DD4 28 Ext/Intl		1500	2700				211	227	240	1
DD5 28 Ext/Intl		1875	3075		2 x PTR25/1000 (132kW) + PTR20/1000 (46kW)	UPS32-100N	241	257	270	1
DD6 28 Ext/Intl		2250	3450		3 x PTR25/1000 (132kW) + 1 PTR20/1000 (46kW)		271	287	300	1
DD7 28 Ext/Intl		2625	3825		301		317	330	1	
DD8 28 Ext/Intl		3000	4200		4 x PTR25/1000 (132kW) + 2 X PTR20/1000 (46kW)		391	419	432	2
DD9 28 Ext/Intl		3375	4575		421		449	462	2	
DD10 28 Ext/Intl		3750	4950		481		479	492	2	
DD2 C32/32 Ext/Intl		500	1000		2200		Refer table below	PTR25/1000 (132kW) + PTR20/1000 (46kW)	UPS32-100N	174
DD3 C32/32 Ext/Intl	1500		2700	214	230	243				1
DD4 C32/32 Ext/Intl	2000		3200	2 x PTR25/1000 (132kW) + PTR20/1000 (46kW)	2 x UPS32-100N	259		59	288	1
DD5 C32/32 Ext/Intl	2500		3700	299		315		328	1	
DD6 C32/32 Ext/Intl	3000		4200	3 x PTR25/1000 (132kW) + 1 PTR20/1000 (46kW)		339		355	368	1
DD7 C32/32 Ext/Intl	3500		4700	379	395	408		1		
DD8 C32/32 Ext/Intl	4000		5200	4 x PTR25/1000 (132kW) + 2 X PTR20/1000 (46kW)	1 x CM10-1	479		507	520	2
DD9 C32/32 Ext/Intl	4500		5700	519		547		560	2	
DD10 C32/32 Ext/Intl	5000		6200	559		587		600	2	

<b>Tank Model (L)</b>	<b>E</b>	<b>F</b>	<b>G</b>	<b>H</b>	<b>I</b>	<b>Dry weight (kg)</b>	<b>Wet weight (kg)</b>
270	625	108	386	1143	1484	84	354
330	625	108	386	1431	1772	98	428
440	720	108	415	1409	1763	122	562

<b>HD Model</b>	<b>J</b>	<b>K</b>	<b>L</b>	<b>M</b>	<b>MJ Rating</b>
HD28e	340	440	540	1500	210
HD28i					210
HD32e					250
HD210e					209
HD210i					209
HDC32					209

## Typical installation for Demand Duo Plus

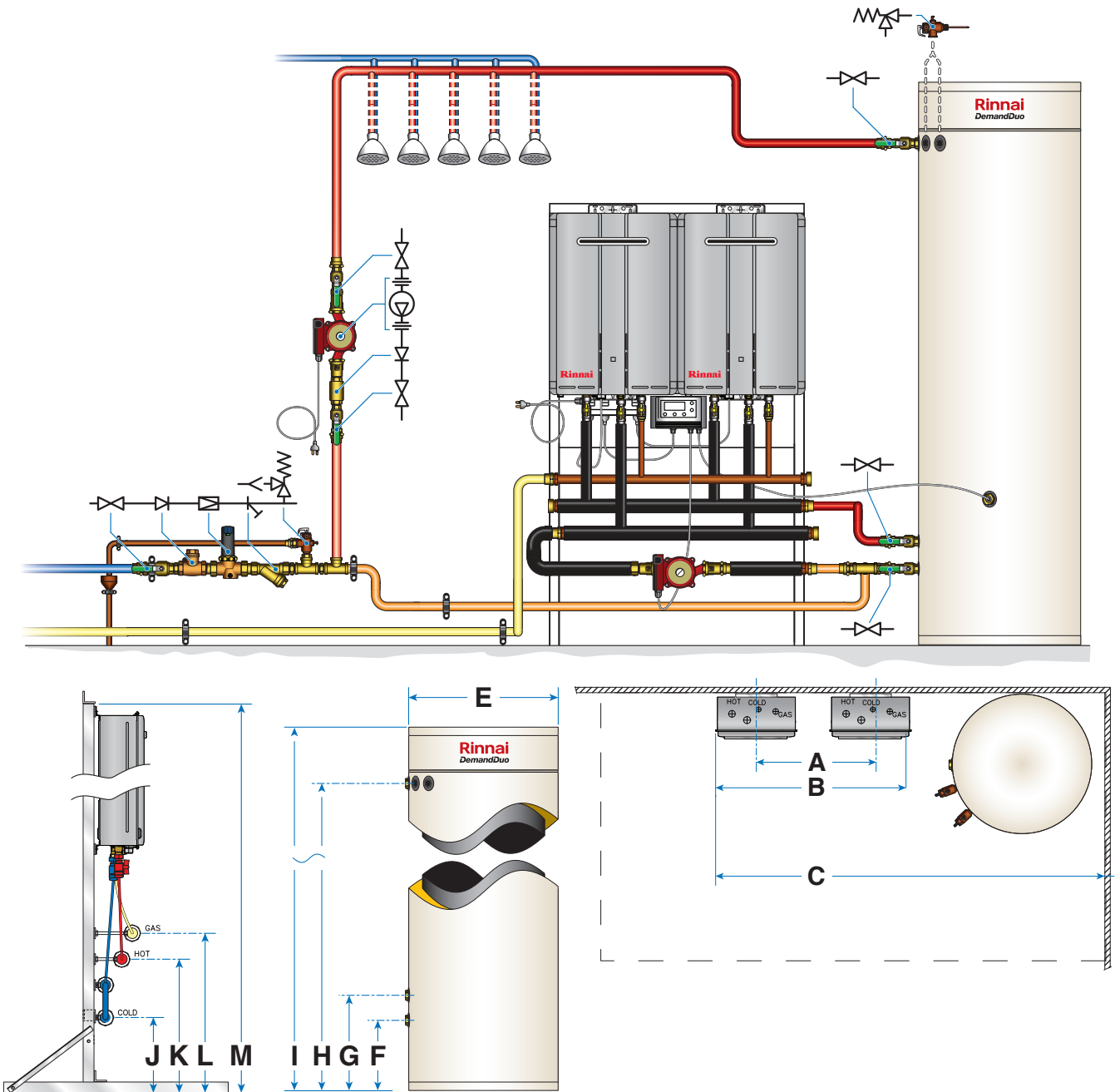

**PRIMARY PUMP(S) MUST BE PLUGGED INTO THE CONTROLLER AND NOT AN AVAILABLE SOCKET OUTLET.**

# INSTALLATION HANDOVER MANUAL

## COLD WATER SUPPLY

- Connect cold water pipe work to one of the cold inlets of tank, including required valves as shown in diagrams on previous page to comply to AS/NZS 3500 and local regulations. (Block any unused cold port(s) with brass plug).
- For 850kPa rated pressure cylinder, Maximum cold water inlet pressure is 650 kPa. Fit pressure limiting valve (rated @ 700 kPa) if cold water inlet pressure is in excess of 650 kPa.
- For 1000kPa rated pressure cylinder, Maximum cold water inlet pressure is 800 kPa. Fit pressure limiting valve (rated @ 850 kPa) if cold water inlet pressure is in excess of 800 kPa.
- Minimum water pressure requirement is 300kPa.
- For ease of draining, it is advisable to fit a "Tee" piece with a capped valve between the cold water isolation valve and the cold water inlet connection on the Demand Duo storage Tank. Tap provided.

Table 1. Pressure Ratings & Other Specifications

Cylinder Rated Pressure (kPa)	PTR Valve Rated Pressure (kPa)	ECV Rated Pressure (kPa)	ECV Fitted	
			Fit PLV if mains pressure exceeds:(kPa)	Recommended PLV pressure rating (kPa)
850	850	700	550	500
1000	1000	850	680	500

A PLV **MUST BE** fitted if the supply pressure exceeds the limits shown. If the mains pressure is within the limits shown fitment of the PLV is optional.



Valves with pressure ratings other than specified are unsuitable and **MUST NOT** be used.

## HOT WATER OUTLET

- Connect hot water outlet pipe to 32mm or 50mm fitting on upper left hand side of the storage Tank with union and isolation valve as required.
- Ensure adequate insulation / lagging is fitted to hot water pipe to minimize heat loss.

## RETURN PUMP

- A secondary or building return pump may be installed in conjunction with the Rinnai Demand Duo hot water system. Pump should be sized for minimal temperature loss around the ringmain. Pump must have a check valve on the discharge.
- Return line from building loop is connected to the cold water supply pipe after the check valve. From that point onwards the cold pipe should be insulated.

## GAS SUPPLY

- Check gas type of Rinnai HD matches gas supply available (LPG or Natural) on job site.
- Gas inlet connection is located at the front bottom of the weather shroud on a DD1 and is the top manifold pipe on a Demand Duo with multiple gas water heater.
- Appropriate gas isolation valve **MUST BE** fitted to DD1.
- Ensure gas pipe sizing is adequate to deliver the required volume / pressure. Pipe size used on inlet fitting is no indication of pipe size required.
- Refer to appropriate pipe sizing chart in Appendix "F" AS/NZS 5601 for appropriate sized gas pipe that should be used to ensure adequate gas supply.
- Gas meter / LPG cylinder & regulator should also be of a suitable size to ensure sufficient gas supply to the gas installation.
- Purge gas pipe to ensure removal of debris etc prior to final connection.
- Check for gas escapes using suitable methods as listed in Appendix "E" AS/NZS 5601.

## ELECTRICAL SUPPLY

- Each water heater consumes approximately 100 Watts when in operation. It is recommended not to exceed 24 heaters on one electric supply circuit. Refer to the manual supplied with the specific water heater for exact requirements.

**FILLING INSTRUCTIONS**

**Do not turn on pump / water heater before cylinder and water heater are completely full of water.**

- Flush cold water inlet pipe to remove any debris before final connection to cold water inlet on Rinnai Demand Duo cylinder.
- Turn on hot water tap to allow air to be expelled while cylinder is filling with cold water.
- Slowly open cold water isolation valve on cold water supply pipe.
- Allow storage tank(s) to fill. Turn off hot water tap once non-aerated water flows through hot water tap.
- Check all connections for water leakage. Tighten as required.
- Purge gas lines until gas is available at water heaters.
- Prime circulating pump(s) before start up by removing chrome screw and allowing water to drip out the end of the pump shaft (as illustrated below).

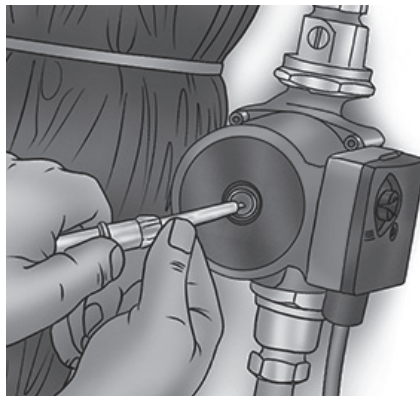

**STARTING INSTRUCTIONS**

- Turn all Socket Outlets ON.
- The temperature controller will initiate.
- For standard systems "75" should appear in the maintenance monitor window on the gas heater. When flow is created by primary pump. That is the outlet temperature from the water heater. It must be higher than the temperature controller set point.
- The temperature controller will display temperature of water in tank. When it reaches the 65°C set point the pump and therefore, water heater will stop. The display on the water heater will not be lit when not operating.

**DEMAND DUO PRINCIPLE OF OPERATION**

Cold water enters the storage tank after passing through an isolation and non return valve.

A tee is fitted to the cold inlet pipe down stream from the non return valve. From this tee, one branch connects to the lower inlet of the storage tank and the other branch connects to the primary (tank circulation) pump. (Not applicable to DD1 Models). This pumps water to the inlet of the heat source. The water heaters will only operate when this pump is running.

The heated water from the HD (s) returns to the tank(s) at the second lowest connection point, located above the cold inlet.

Hot water leaves the tank from the top of the tank. This may be circulated around the building and returned, via a ringmain pump (set) to the cold inlet before the tee as described above.

When there is a hot water draw off, cold water enters the tank and pushes the hot water out of the tank towards the outlet, as per any storage hot water system.

When the temperature in the tank drops below the temperature set point, the temperature controller activates the primary pump(s). They draw water from the cold water feed to the tank, the tank itself, or a combination of both. As stated previously, this water is then heated by the HD (s) and returns to the tank heated. This process is continued until the temperature set point is reached and the pump is switched off.

The outlet temperature controller setting of the HD (s) must be set at least three (3) degrees hotter than the controller set point. Factory settings are: HD (s) 75°C, Thermostat 65°C.

**THERMOSTATIC CONTROLLER OPERATION**

A Demand Duo system generally has a thermostatic control module that is factory preset and designed to control the operation of primary pumps between storage tank and external heat source, such as HD28, HD32 and HDC32. It has many functions and temperature sets points available which are described in the manual provided with the controller.

A Demand Duo with one integrated HDC32 water heater may not have this control module. This is due to the water heaters capability to operate with the need for an external device. These units are factory set and as a rule can not be programmed on site. However, if you require settings differing to the factory default, such as a different tank temperature, then please contact us for technical assistance on the contact details provided on the back page.

**DEMAND DUO PREVENTATIVE MAINTENANCE**

**All Items**

- Inspect for damage, corrosion or water leaks.

**Tank**

- Ensure that tank is not leaking.
- Ensure that PTR valves are not leaking. It is normal for PTR valve to operate during the heating cycle, relieving pressure as the water is expanding. The PTR Valve is rated to 850 kPa and cold inlet pressure should not exceed 500-700 kPa. If it does, then a pressure reduction valve should be fitted to the cold water inlet.
- Valve may be operating if water temperature in tank is close to 99°C. If this is the case thermostatic controller or other heating equipment has failed to operate correctly. Contact Rinnai service department.
- If pressure and temperature are low but valve is leaking, pull the lever for up to 30 seconds, as some foreign material may be jammed in the valve seat. If valve fails to seat correctly, valve should be replaced. PTR Valves are a non-repairable safety device and should be replaced with the correct model and pressure rating.

**Primary Pump**

- Primary pumps are plugged into the relevant position on the thermostatic controller. Refer to manual provided with the controller.
- Some projects may have larger and/or dual pumps for redundancy or long primary pipe run situations.
- Pump(s) operate only when activated by the thermostatic controller and the pump operation is indicated on the controller screen.
- Ensure that pumps are installed in a weather proof location or protected from being subjected to water ingress. Wet pump electrics may cause failure. Water can run along power lead so keep the lead looping under the pump and curving upwards toward the electrical box.

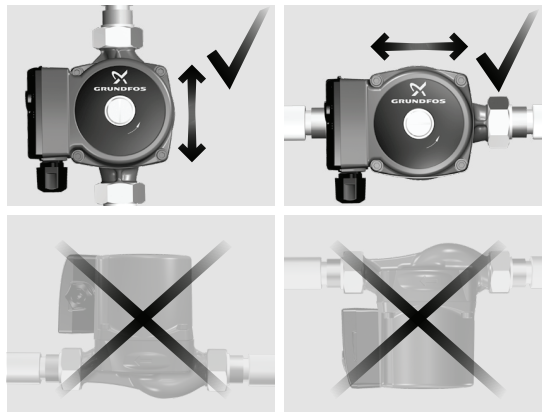

- Ensure shaft is horizontal. **DO NOT** aim shaft upwards or downwards.
- **DO NOT** locate terminal box under pump housing. Position it on top preferable or on side
- **Bleed pump with chrome screw at end of pump casing.** This will be facing towards you when the pump shaft is horizontal. Pump runs on water bearing and is critical for life of pump. Excessive noise indicates damage or lack of bleed.
- When this screw is removed the spinning / stationary impeller shaft can be inspected.
- Ensure pump direction of flow arrow is towards the heat source.
- If shaft is spinning but there is no flow: Check ball valves and any non return valve for correct installation and operation. Primary pumps have inbuilt ball valves in the unions. Line up screwdriver slot parallel to pipe to position them open.

**HEAVY DUTY (HD) HEAT SOURCE**

- Ensure that filter at water inlet is clean. **NOTE: that this is an 'O' ring seal and does not need to be excessively tightened. Just make sure 'O' ring is engaged inside machined surface in brass housing. Isolate water supply to DD before removing filter for cleaning and inspection. Ensure water in storage cylinder is not excessively hot before removing HD inlet filter.**
- Ensure all HD (s) are operating. Ensure power is available to HD (s) if it is not operating. Check Socket Outlet. Ensure power is available to the HD (s) before applying power to thermostatic controller and pump(s).
- Many new jobs or ones where the gas supply has been modified need to purge the gas supply lines as they are full of air. Purge should be carried in accordance with AS/NZS 5601, Appendix 'D'.
- Look at flame through inspection window for conical shape, blue base and yellow tip. Flame height will vary if heater is modulating. Inspection window is located behind the front cover on the burner unit (next to flame rod) of the appliance.
- All HD models: when operating the number displayed should be higher than the temperature setting on the thermostatic controller.
  - Eg Tank = 65°C, HD = 75°C. These are factory standard settings.
  - Eg Tank = 82°C, HD = 85°C. These are the maximum allowable settings.
- All HD models will display a fault number if one has occurred. The following table lists all of the fault codes.
- In jobs that operate for long hours and/or in dusty or smoky environments the combustion air fan may become dirty. This may be indicated by fault 10. Contact Rinnai Service.
- Internal heaters may operate for a short period of time and then stop. This can be caused by the flueing not being pushed together properly and exhaust gases are re-entering the inlet air. Push the flue together to remedy this. Also inspect flue terminal for any cause to divert exhaust air back into the inlet air. Ensure flue is terminated correctly in accordance with AS/NZS 5601.

**For Internal (FFU) models only (except HD210i & HDC32)**

Have you used only RINNAI FFU flueing components?

If flue exceeds 7m, dip-switch 1 of SW1 is to be switched to the 'OFF' position as shown.

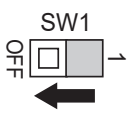

**FLUE LENGTH DIPSWITCHES - REU-VCM**

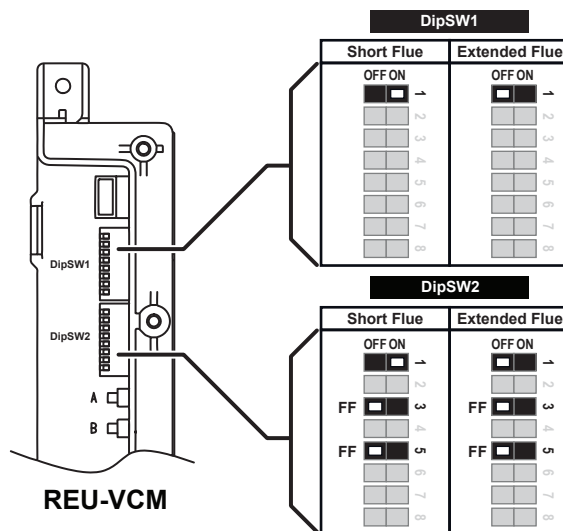

**Short flue:** Installations where the total flue does **NOT** exceed 7 metres (refer to diagram), the SW1 of both DipSW1 & dipSW2 are set to 'ON'.

**Extended flue:** Installation where the total flue length exceeds 7 metres (refer to diagram), the SW1 of both DipSW1 & DipSW2 are set to 'OFF'.

## FAULT FINDING

The Rinnai Continuous Flow water heaters have self diagnostic capability. If a fault occurs, an Error Code will flash on the status monitor or inbuilt controller. If you have Temperature Controllers, this assists with diagnosing the fault, and may enable you to overcome a problem without a service call. Please quote the code displayed when enquiring about service.

### HD Fault Codes

Code	Description	Remedy
-	Noticeable reduction in water flow	Inlet water filter needs to be cleaned - Service call
03	Power interruption during Bath fill (Water will not flow on power reinstatement)	Turn off all hot water taps Press On/Off twice
05	By-Pass Flow Control Failure	Service Call
10	Air Supply or Exhaust Blockage or Condensate Pipe Blockage	Service Call
11	No ignition / No gas supply	Check gas is turned on at water heater and gas meter or cylinder
12	Flame Failure / Low gas flow	Check gas is turned on at water heater and gas meter or cylinder. Check there are no obstructions to the flue outlet
14	Heat Exchanger Overheat Failure	Service Call
15	Venturi Control Failure	Service Call
16	Over Temperature Warning	Service Call
17	Venturi Blockage	Service Call
19	Electrical Earthing Failure	Service Call
21	Data Transfer Error	Service Call
32	Outgoing Water Temperature Sensor Failure	Service Call
33	Heat Exchanger Thermistor Failure	Service Call
34	Combustion Air Temperature Sensor Failure	Service Call
38	Exhaust Thermistor Failure	Service Call
41	Freeze Protection Thermistor Failure	Service Call
51	Inlet Thermistor Failure	Service Call
52	Gas Valve Failure	Service Call
54	High Exhaust Gas Temperature Failure	Service Call
55	Scheduled Service Reminder	Service Call
5E	Cascade Connection Failure	Service Call
61	Combustion Fan Failure	Service Call
65	Water Flow Control Failure (Does not stop flow properly)	Service Call
70	PCB Failure	Service Call
71	Solenoid Valve Circuit Failure	Service Call
72	Flame Rod Failure	Service Call
	Wireless water controller (when fitted) is 'Out of Range' due to the distance from transceiver or an obstruction.	Move wireless water controller or transceiver or remove the obstruction.



Some fault codes are model specific and so not all codes will display on all models. If the fault code being displayed is not listed above, contact Rinnai for advice.

In the majority of cases, you may be able to clear the Error Code simply by turning the hot water tap OFF, then ON again. If this does not clear the Error Code, try pushing the On/Off button OFF, then ON again. If the Error Code still remains, contact Rinnai for advice.

**RINGMAIN PUMP**

- These are used for circulating water around the building. They are normally left on or may have a time clock to switch it off at night when the building is not in use.
- These pumps do not pressurise the system.
- They must have a non return valve.
  - Swing non return valves must be horizontal or upward as they rely on gravity to close the valve.
  - Spring check valves can be located on any plane but may contribute excessive back pressure and restrict the pump flow rate.
- Return water should only be slightly cooler than water leaving the tank. If the temperature drop around the circuit is too high it may indicate that the ring main pump flow rate is not high enough and indicates a design fault or a blockage in the pipework (or poor pipework insulation). Investigate valves and operation of pump (same procedure as primary pump).

**SERVICE**

Rinnai recommend that all commercial water heater installations have a service arrangement.

Annual services are recommended at a minimum. Refer to the back cover for contact information.

## DETAILS

Company	
Phone No,	
Email	
Date	
Project	

## COMMERCIAL HOT WATER SYSTEM COMMISSIONING CHECK-LIST

System Details		
<b>Product Code</b>		
Installation Type	External / Internal	
Number of Water Heaters		
Water Heater Model		
Gas Type	Natural / LPG	
Number of Storage Tanks		
Storage Tanks Model		
Number of Primary Pump/s & Control System/s		
Pump/s Model		
Number of Return Pump/s		
Pump/s Model		
Installation		
Overall Installation – Satisfactory?	Yes / No	
Cold Water Strainer, Check Valve, PLV Isolation Valve/s Installed?	Yes / No	
Return Strainer Installed?	Yes / No / NA	
Storage Tanks' hydraulically balanced?	Yes / No / NA	
Ventilation Requirements – Satisfactory?	Yes / No	
Individual Co-Axial Flue Installation – Satisfactory?	Yes / No / NA	
Dip Switch Setting	Short / Long	
Common Flue Installation – Satisfactory?	Yes / No / NA	
Primary Pump/s Vented?	Yes / No / NA	
Return Pump/s Vented?	Yes / No / NA	
Air removed from flow and return hydraulic circuit?	Yes / No	
All drains to tundish completed?	Yes / No	
Socket Outlet Installation – Satisfactory?	Yes / No / NA	
MECS/Cascade Staging System wiring completed?	YES / No / NA	
Parameters		
Gas Pressure (@1.13-2.75kPa-NG) / @2.75kPa-LPG)		
• Static		
• Running		
Inlet Water Pressure (kPa)		
Permanent Power Supply (V/Phase/Hz/A)	240/1/50	

<b>General System Operation</b>		
All Valves in Open Position	Yes / No	
Controller Set Temperature (°C)		
Water Heater Set Temperature(°C)		
Return Pumps Controller Set Mode		
Water Heater/s Operation – Satisfactory?	Yes / No	
Tanks’ PTR Valves’ Operation – Satisfactory?	Yes / No	
Staging System Operation – Satisfactory?	Yes / No / NA	
Primary Pump/s Operation – Satisfactory?	Yes / No / NA	
Return Pump/s Operation – Satisfactory?	Yes / No / NA	
Storage Tank Reached Temperature?	Yes / No / NA	
Return Water Temperature?		
Overall System Operation – Satisfactory?	Yes / No	
<b>Comments</b>		
<p>Client to carry out regular preventative maintenance as below:</p> <ul style="list-style-type: none"> <li>● Inlet Strainer/s; Hot Water Return Strainer &amp; Water Heaters Inlet Strainers: Once every week for the first month &amp; three monthly from there onwards</li> <li>● For other details refer to Operation &amp; Maintenance Manual</li> <li>● For effective operation of the system; service the package once every six (6) months as per the manufacturer’s instructions.</li> <li>● In compliance to AS/NZS 5601.1 figure 6.2 minimum clearance required for any air intake from the exhaust of a water heater is 1500mm.</li> <li>● In compliance to AS/NZS 3500.2 section 6.8.4 termination clause (e), vents shall terminate in the open air and in a location not less than 5.0m in any direction from any air duct intake.</li> <li>● Warranty:  <a href="https://www.rinnai.com.au/wp-content/uploads/2018/02/15401043-V6-Commercial-Warranty-Booklet.pdf">https://www.rinnai.com.au/wp-content/uploads/2018/02/15401043-V6-Commercial-Warranty-Booklet.pdf</a></li> <li>● Installation of system to comply within Rinnai installation guidelines and relevant codes</li> <li>● Drainage: Provide appropriately designed drainage system in compliance to applicable building codes and regulations to prevent property and equipment damage.</li> </ul>		
<b>Customer Representative</b>	<b>Date</b>	







# Rinnai Australia Pty Ltd

ABN 74 005 138 769 | AU45204

82-88 Mills Road, Braeside, Victoria, 3195  
P.O. Box 460, Braeside, Victoria, 3195  
Tel: (03) 9271 6625

## **Customer Support**

Tel: 1300 555 545\*

*Monday to Friday, 8.00 am to 5.00 pm EST.*

## **After Hours Hot Water Service Line**

Tel: 1800 000 340\*

*\*Cost of a local call may be higher from a mobile phone.  
(National calls from public phones in Australia are free.)*

For further information visit **[www.rinnai.com.au](http://www.rinnai.com.au)**  
or email **[enquiry@rinnai.com.au](mailto:enquiry@rinnai.com.au)**

Rinnai has a Service and Spare Parts network with personnel who are fully trained and equipped to give the best service on your Rinnai appliance. If your appliance requires service, please call Customer Support. Rinnai recommends that this appliance be serviced once a year.

With our policy of continuous improvement, we reserve the right to change, or discontinue at any time, specifications or designs without notice.