

MODELS

RINNAI SS850

(SS850ICAN) NG

RINNAI SS850

(SS850ICAL) LPG

RINNAI SS850

(SS850CLN) NG

RINNAI SS850

(SS850ICLL) LPG

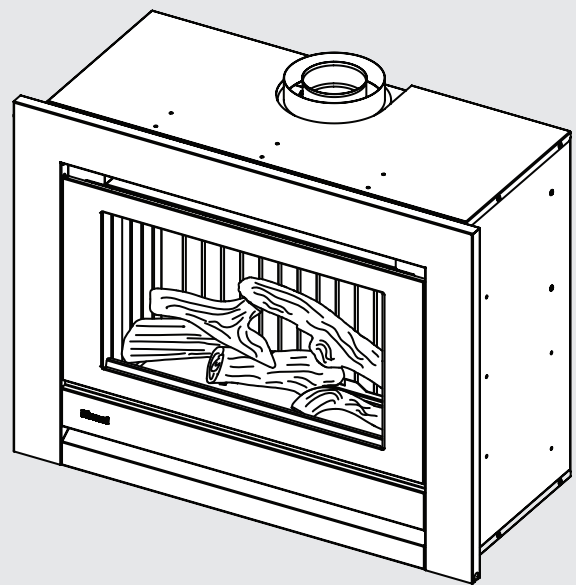
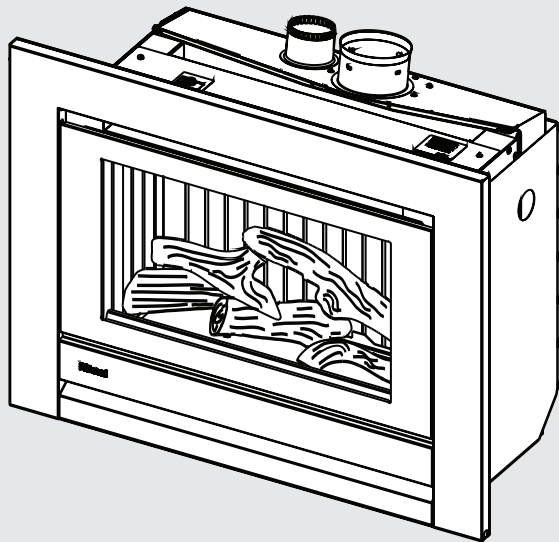

# Gas Fireplace

## Installation Manual

# Rinnai

Congratulations on the purchase of your Rinnai SS850 Gas Fire. We trust you will have many years of comfort and enjoyment from your appliance.



### **BEFORE INSTALLING THIS APPLIANCE**

Before proceeding with the installation read this manual thoroughly and gain a full understanding of the appliance, to ensure safe and correct use.

For details on how to use this appliance refer to the Operation Manual Part Number: 13722.

This appliance must be installed in accordance with:

- Manufacturer's Installation Instructions
- Current AS/NZS 3000, AS/NZS 3500 & AS/NZS 5601
- Local Regulations and Municipal Building Codes including local OH&S requirements

This appliance must be installed, maintained and removed **ONLY** by an Authorised Person.

For continued safety of this appliance it must be installed and maintained in accordance with the manufacturer's instructions.



**The Australian Gas Association**  
All Rinnai gas products sold in Australia are A.G.A. certified.

# TABLE OF CONTENTS

<b>Warnings &amp; Important Information</b>	<b>4</b>
Before Using or Installing this Appliance .....	4
Regulatory Information .....	4
Notice to Victorian Consumers .....	4
Dress Guard Warnings .....	4
Mandatory Inspection Prior to Installation .....	4
Modifications .....	5
General Safety Warnings .....	5
<b>Before You Start</b>	<b>6</b>
Installation Requirements .....	6
Certification .....	6
<b>General Installation Information</b>	<b>7</b>
Location .....	7
Flooring and Hearth Material Selection .....	8
TV Installation .....	9
<b>Framing</b>	<b>10</b>
Enclosure Requirements .....	10
<b>Supply Connections</b>	<b>11</b>
Gas Supply .....	11
Electrical Supply .....	12
<b>Flueing</b>	<b>13</b>
General Flueing Guidelines .....	13
Flueing Option: Masonry .....	14
Flueing Option: False Fireplace .....	15
Flue Components .....	16
Flue Installation Dimensions & Restrictions Flue Terminal Clearances .....	18
<b>Installation</b>	<b>19</b>
False Fireplace Installation .....	19
Masonry Installation .....	21
Aeration Plates .....	23
Fire to Flange Connection .....	24
<b>Burner Media Installation</b>	<b>25</b>
Burner Media Placement .....	25
<b>Commissioning</b>	<b>27</b>
General Information .....	27
Commissioning the Appliance for Different Gas Type .....	30
Attaching Fascia Assembly .....	31
Abnormal Flame Pattern .....	32
<b>Installation Checklist</b>	<b>33</b>
<b>Specifications</b>	<b>34</b>
Appliance Details .....	34
Dimensions .....	35
Wiring Diagram .....	36
<b>Contacts</b>	<b>40</b>



This appliance **MUST** be installed, maintained and removed **ONLY** by an Authorised Person.  
For continued safety of this appliance it **MUST** be installed and maintained in accordance with the manufacturers instructions.

# WARNINGS & IMPORTANT INFORMATION



## BEFORE INSTALLING THIS APPLIANCE

Before proceeding with the installation read this manual thoroughly and gain a full understanding of the appliance, to ensure safe and correct use.

Failure to carefully read and follow all instructions in this manual can result in equipment malfunction, fire or explosion, property damage, personal injury and/or death.

**DANGER:** Indicates an imminently hazardous situation which, if not avoided, will result in personal injury or death.

**WARNINGS:** Indicates a potentially hazardous situation which, if not avoided, could result in personal injury or death.

**CAUTIONS:** Indicates a potentially hazardous situation which, if not avoided, could result in minor or moderate injury or damage to the appliance. It may also be used to alert against unsafe practices.



## REGULATORY INFORMATION

This appliance shall be installed in accordance with:

Manufacturer's Installation Instructions.

Current AS/NZS 3000, AS/NZS 3500 & AS/NZS 5601.

Local Regulations and Municipal Building Codes including local OH&S requirements.

This appliance has been certified by the Australian Gas Association. The A.G.A. Certification Number is shown on the data plate.

This appliance **MUST** be installed, maintained and removed **ONLY** by an Authorised Person.

For continued safety of this appliance it **MUST** be installed and maintained in accordance with the manufacturer's instructions.

## NOTICE TO VICTORIAN CONSUMERS

This appliance **MUST** be installed by a person licensed with the Victorian Building Authority. **ONLY** a licensed person will have insurance protecting their workmanship.

So make sure you use a licensed person to install this appliance and ask for your Compliance Certificate. For further information contact the Victorian Building Authority on 1300 815 127.



## DRESS GUARD WARNINGS

The guard is fitted to this appliance to reduce the risk of fire or injury from burns and no part of it should be permanently removed. For protection of young children or the infirm, a secondary guard is required.

The glass dress guard supplied with this appliance **MUST NOT** be permanently removed as it fulfils an operational safety function. Additional dress guards including free standing types may be used in conjunction with, but **NOT** replace, the dress guard supplied with this appliance.



## MANDATORY INSPECTION PRIOR TO INSTALLATION

Immediately report any damage or discrepancies to the Supplier of the appliance. This appliance was inspected and tested at the time of manufacture and packaging, and released for transportation without known damage. Upon receipt, inspect the exterior for evidence of rough handling in shipment. Ensure that the appliance is labelled correctly for the gas and electrical supply, and/or other services it is intended to be connected to.

For safety and warranty purposes, appliances that may be damaged or incorrect **MUST NOT** be installed or operated under **ANY** circumstances. Installation of damaged or incorrect appliances may contravene local government regulations. Rinnai disclaims any liability or responsibility whatsoever in relation to the installation or operation of damaged or incorrect appliances.

Take care when opening or unpacking this appliance. Failure to do so may result in serious injury or product failure.

Check the label for the correct gas type (refer rating plate, inside the appliance). Refer to local gas authority for confirmation of the gas type if you are in doubt.



**MODIFICATIONS**

**DO NOT MODIFY THIS APPLIANCE**, modifying from original specifications may create a dangerous situation and will void your warranty. Failure to comply with these instructions could result in a fire or explosion, which could cause serious injury, death or property damage.

**DO NOT** modify the electrical wiring of this appliance.

If the power cord is damaged or deteriorated it **MUST** be replaced by an authorised person. Failure to do so may result in electric shock, fire, serious injury or product failure.

Improper installation, adjustments, service or maintenance can cause serious injury, death or property damage. Such work **MUST ONLY** be performed by an authorised person.



**GENERAL SAFETY WARNINGS**

This appliance is **HEAVY**, during installation the use of a mechanical lifting aid is recommended, noting that improper lifting may result in serious injury.

**WARNING:** This heater **MUST NOT** be used if any of the glass panels are damaged.

Flue terminal **MUST** always vent directly to outdoors. **DO NOT** extend the flue vertically or horizontally in ways other than prescribed in this appliance manufacturer’s installation instructions. **ONLY** the flue components specified by Rinnai **MUST** be used.

When considering installation ensure minimum clearances as follows are adhered to.

Heat radiating from the front of this heater may over time affect the appearance of some materials used for flooring such as carpet, vinyl, cork or timber. This effect may be amplified if the air in the room contains cooking vapours, candle vapours and cigarette smoke, etc. Refer to "Location" on page 7 for mantel clearances, additional installation information and warnings.

This appliance **MUST NOT** be installed where curtains or other combustible materials could come into contact with it. In some cases curtains may need restraining.

This appliance is **NOT** intended for use by persons (including children) with reduced physical, sensory or mental capabilities or lack of experience and knowledge, unless they have been given supervision or instruction concerning use of the appliance by a person responsible for their safety.

The appliance is **NOT** intended for use by young children or infirm persons without supervision. Young children and the infirm **SHOULD** be supervised at all times when in the vicinity of this heater while it is in operation.

The heater **MUST NOT** be located immediately below a power socket outlet.

A dedicated 230 V earthed 10 Amp power point must be used with this appliance.

Refer to local gas authority for confirmation of the gas type if you are in doubt.

Suitable **ONLY** for indoor installation.

**DO NOT** operate this appliance before leak checking hoses and gas cylinder connection.

This heater **MUST NOT** be used if either of the glass panels are damaged.

**NOT** to be connected to an LP gas cylinder located indoors.

Please keep this instruction booklet in a safe place for future reference. All dimensions referred to in these instructions are in millimetres, unless otherwise specified.

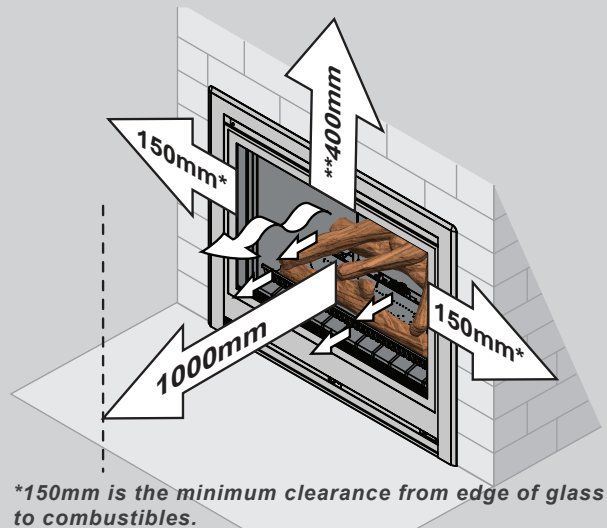

*\*150mm is the minimum clearance from edge of glass to combustibles.*

*\*\*400mm is the minimum top clearance from edge of glass to combustible items other than mantel, overhanging 250mm or less. (Refer Mantel Clearances, page 7 and TV Installation, page 9)*

# BEFORE YOU START

## INSTALLATION REQUIREMENTS

This heater **MUST** be installed **ONLY** by an authorised person.

The installation **MUST** conform to local regulations.

The installation **MUST** also comply with the instructions supplied by Rinnai.

Service and removal **MUST** be carried out **ONLY** by an authorised person.

## CERTIFICATION

The Rinnai SS850 Gas Fire has been certified by the Australian Gas Association.

The AGA Certification Number is shown on the appliance data plate.

No parts or functions should be modified or permanently removed from the heater.

Please keep these instructions in a safe place for future reference.

## CARTON CONTENTS / ITEM CHECKLIST

The following table lists the components for the Rinnai SS850 Gas Fires. Ensure that all the relevant components for the model being installed are present before proceeding.



**DO NOT** Install any damaged items. Check all components have been supplied.

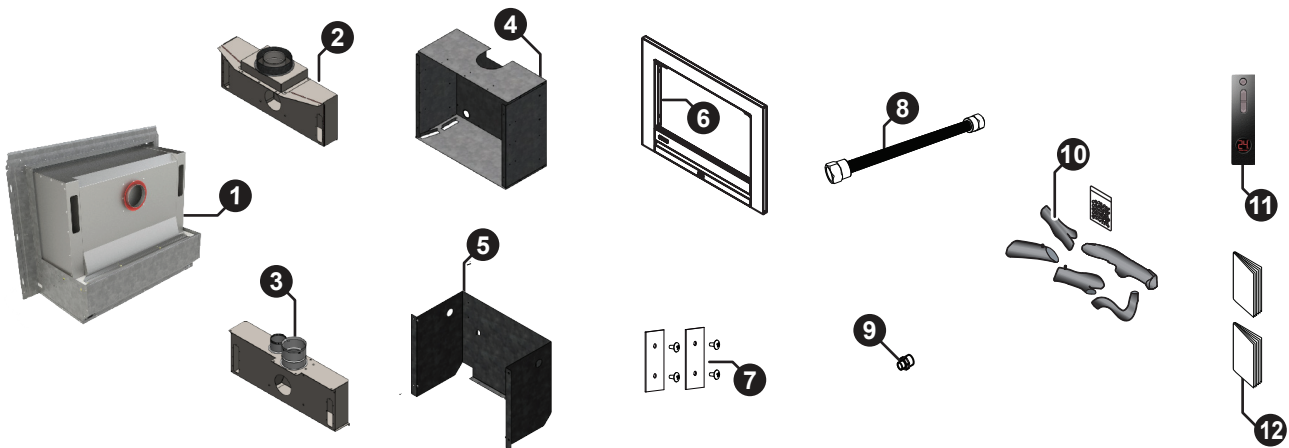

Major component descriptions and carton contents		SS850ICLN (NG)	SS850ICAN (NG)
		SS850ICLL (LPG)	SS850ICAL (LPG)
①	Rinnai SS850 Engine.	●	●
②	Coaxial adapter.	N/A	●
③	Colinear adapter.	●	N/A
④	Zero clearance box.	N/A	●
⑤	Masonry adapter frame.	●	N/A
⑥	Four sided fascia.	●	●
⑦	Aeration plate and screws. Two are factory fitted on the engine, two are supplied in the accessory pack.	●	●
⑧	Semi rigid stainless steel gas pipe with 5/8" connections (x1).	●	●
⑨	1/2" BSP - 5/8" UNF flared brass adaptors (x1).	●	●
⑩	Ceramic log set and granules.	●	●
⑪	Remote Control, Infra Red (IR).	●	●
⑫	Operation and Installation manual.	●	●

# GENERAL INSTALLATION INFORMATION

## LOCATION

When positioning the heater, the main variables governing the location are Flueing and Warm Air Distribution.

### Combustible clearances

The heater **MUST NOT** be installed where curtains, furniture or other combustible materials could come into contact with the fire while it is operating. The 150 mm side clearance, measured from the edge of the glass, includes side walls. The 1000 mm clearance is in front of the fire.

### Hearths

A hearth is not necessary but can be used for decorative purposes. It **MUST NOT** obscure the front of the fire or obstruct the fire in any way. For more information refer next page.

### Floor protection

Heat radiating from the fire may affect the appearance of some materials used for flooring such as vinyl planks, carpet, cork, or timber. To avoid this occurring it is recommended a mat be placed in front.



**Carpet MUST NOT** be fitted hard up against the fire as it will affect operation

### Mantels and surrounds

Combustible mantels and surrounds require clearance from the unit to minimise the risk of fire. They are allowed providing they are outside the minimum clearances shown.

The SS850 gas fireplace is not designed to be built into bookcases.

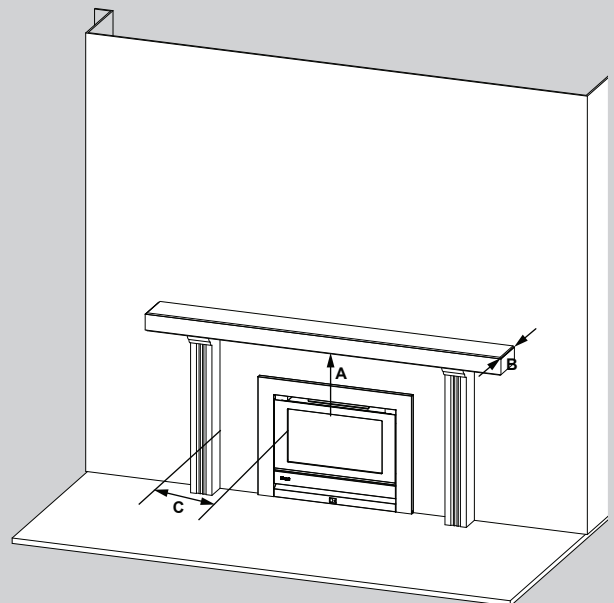
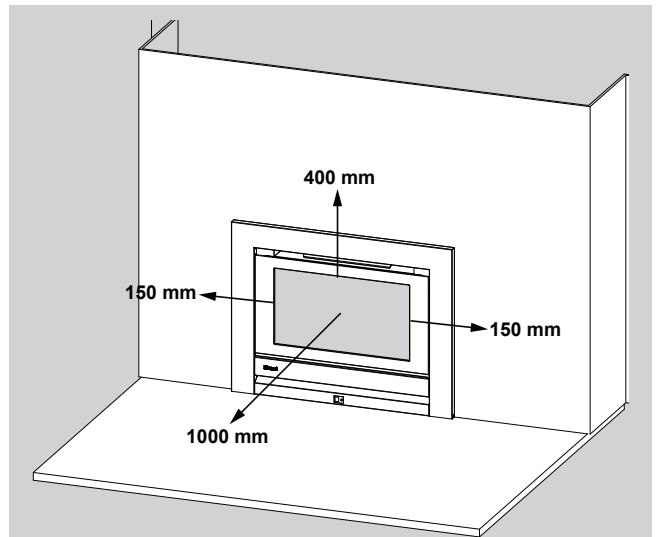

<b>A</b>	Mantel needs to be a min. of 400 mm away from the edge of the glass
<b>B</b>	Max. mantel depth at 400 mm (A) is 250 mm
<b>C</b>	Surround needs to be a minimum of 150 mm away from the edge of the glass

For every 50 mm of added mantel depth there must be an additional 100 mm of clearance from the edge of the glass. For example:

Mantel depth (B)	Vertical clearance req (A)
250 mm	400 mm
300 mm	500 mm
350 mm	600 mm
400 mm	700 mm

**FLOORING AND HEARTH MATERIAL SELECTION**

The temperature in front of the fire (200-350 mm x 400 mm wide) can reach up to 40 °C above ambient, therefore material selection is important. Some guidelines are detailed below. For example, vinyl planks are often only rated for ambient temperatures. Consequently, the heater would not be suitable for installation directly on that flooring type.

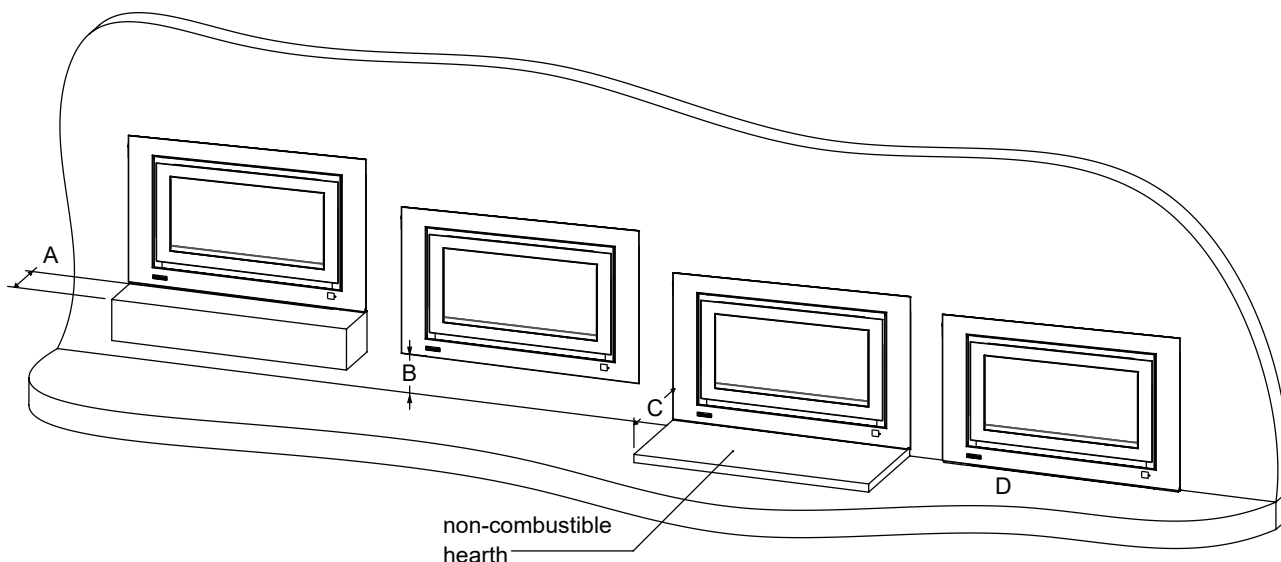

Dim.	Non-combustible materials or materials rated to 60 °C or higher above ambient	Materials rated to a maximum of 50 °C above ambient	Unrated materials, anything up to 20 °C above ambient
A	No maximum.	150 mm maximum <sup>1</sup>	100 mm maximum <sup>1</sup>
B	No minimum	150 mm minimum	300 mm minimum
C	No minimum	400 mm minimum	450 mm minimum
D	No restriction	Not suitable for carpets or any heat sensitive materials	

<sup>1</sup> Refer floating hearth section below

Even if a material is rated above 60 °C it may still be subject to deterioration when exposed to heat cycles. Always refer to the materials supplier for suitability. The temperatures given assume the heater is operating in a room temperature of no more than 25 °C. Operation in higher ambient temperatures may result in higher surface temperatures.

**Floating hearth - low rated and unrated flooring materials**

For unrated flooring materials, if you use a non-combustible floating hearth, the dimensions of the hearth, minimum depth and minimum height can be optimised using the following calculations:

**Min. hearth depth (A) = 450mm - height of hearth (for 50 °C rated materials it will be 400mm)**

**Min. hearth height (B) = 450mm - depth of hearth (for 50 °C rated materials it will be 400mm)**

**Example**

For a 200mm deep non-combustible hearth, the calculation for hearth height would be:

450mm - hearth depth (A) (450mm - 200mm = 250mm). The non-combustible hearth height would need to be 250mm minimum.

This would mean the floating hearth dimensions could be 200mm deep and 250mm high.

**TV INSTALLATION**

The SS850 has a fan that distributes warm air from the top of the appliance out into the room. As warm air is dispersed outwards and not directly upwards, installation of a TV may be an option.

The general rule for television installations is that the bottom of the television should be at least 400-450 mm above the fire.

For a TV mounted directly above the fire, the mantel must be at least the depth of the TV to deflect heat away.

It is the responsibility of the owner to confirm with the TV manufacturer the suitability of such an installation and any conditions in the TV warranty that may apply to this.



Use either a shelf or mantel below the TV or ornament or alternately you can construct a recess to mount TV or ornaments in. Check the manufacturer's installation instructions for these items and ensure the recess is suitable.

**TV Installation with Mantel**

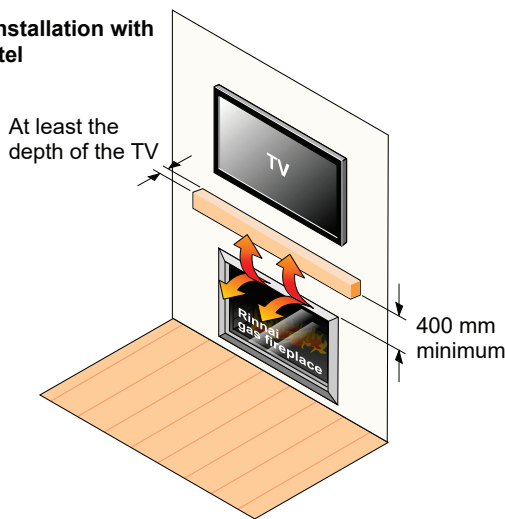

**TV Installation with Recess**

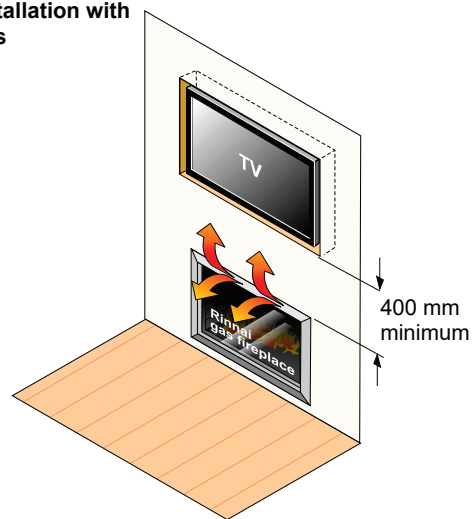

**RINNAI DOES NOT TAKE ANY RESPONSIBILITY FOR ANY DAMAGE OCCURRING TO ANY ITEMS INSTALLED ABOVE AND IN THE VICINITY OF THE HEATER.**



**INSTALLATION OF TV OR ORNAMENTATION ABOVE THE HEATER**

The installation of electrical appliances above and in the vicinity of the heater such as, but not limited to, TVs, Home Theatre Screens, Speakers, etc., **MUST** comply with their manufacturer's' instructions. It is the responsibility of the installer/end-user to check the installation instructions of these items and to ensure the location is suitable.

This caution also extends to, but is not limited to, ornaments such as: Paintings, Prints, Photographs, Tapestries, Mirrors, Stuffed Animals, etc.

Please note the recommended clearances in the diagrams above. Wall surface temperature may be elevated directly above the appliance and may discolour paint finishes or distort vinyl coverings. For durability of surfaces consult the relevant manufacturer's specification.

# FRAMING

## ENCLOSURE REQUIREMENTS

### Masonry Fireplace Installation

The appliance **MUST** be positioned within the fireplace on a flat level surface.

If the appliance is elevated from the ground within the structure, a base **MUST** be constructed using suitable material with supporting joists capable of supporting a minimum of 1.5 times the weight of the appliance.



In a masonry fireplace, use a slurry of sand and cement to level the base as required.

### False Fireplace Installation

Framework of the installation **MUST** conform to local building codes. Non-combustible materials need not be used. If the appliance is elevated from the ground within the structure, a base **MUST** be constructed using suitable material with supporting joists capable of supporting a minimum of 1.5 times the weight of the appliance.



AS/NZS 5601 "GAS INSTALLATIONS" requires that flue components be supported independently of the appliance.

### Enclosure Dimensions

Enclosure dimensions are shown below. The enclosure dimensions specified **MUST** be strictly adhered to.

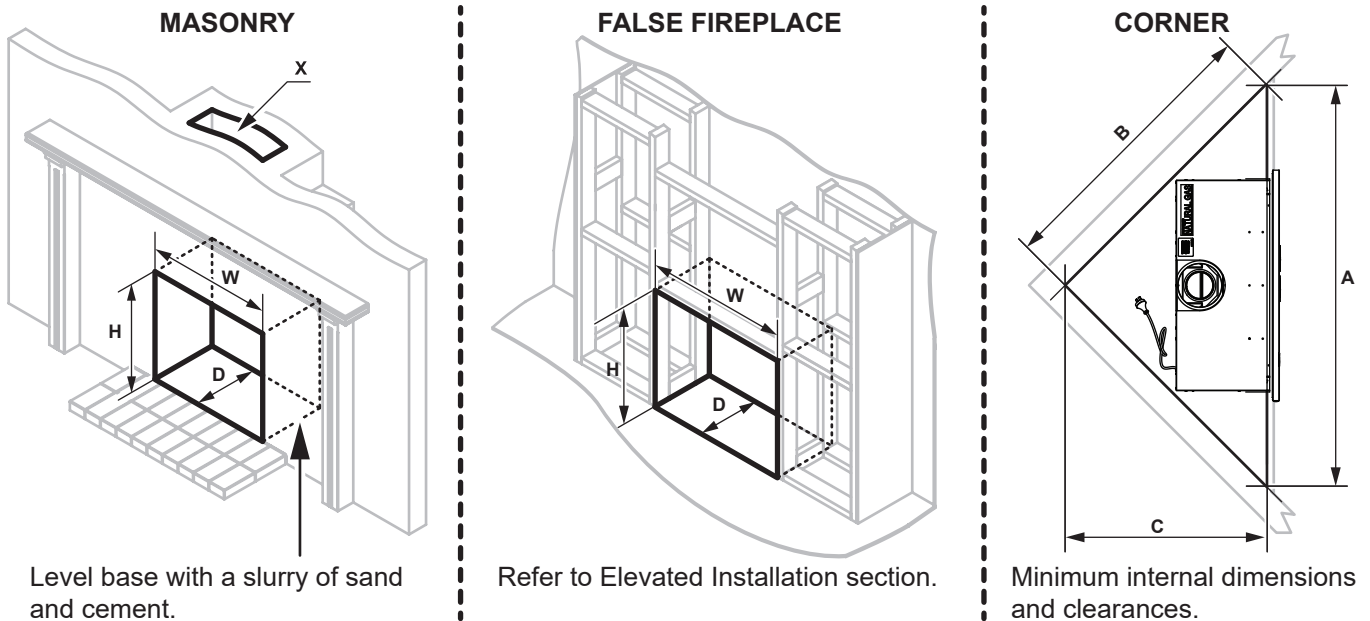

Enclosure Type (All dimensions are minimums and are in mm unless otherwise stated)										
Model	Masonry				False Fireplace			Corner ‡		
	Height (H)	Width (W)	Depth (D)	Chimney (X)	Height (H)	Width (W)	Depth (D)	Face (A)	Sides (B)	Depth (C)
SS850	600	700	370 *	200 x 200	655 #	800 #	370 *	1550	1105	788
With Infill Panel										
	1030	740	370							



The co-linear flexible flue **MUST NOT** come into contact with **ANY** combustible material.

# The larger enclosure dimension for False Fireplace installations allows fitment of the zero clearance frame. This frame is necessary to provide the required clearances from combustibles.



\* When preparing the cavity the minimum depth must be inclusive of the external cladding thickness for false fireplace installations. It is the installers responsibility that adequate clearance be provided between the heater engine and electrical connections.

‡ Corner installations use False Fireplace enclosure dimensions and framing specifications.

# SUPPLY CONNECTIONS

## GAS SUPPLY



Gas pipe sizing **MUST** consider the gas input to this appliance as well as all other gas appliances in the premises. The gas meter and regulator **MUST** be specified for the total gas rate.

A suitable sizing chart such as the one in AS/NZS 5601 should be used.

The use of rubber hose for any gas connection to a fixed appliance is **NOT** authorised by the manufacturer.



Confirm correct gas type (see labels located on top or rear panels). Refer to local gas authority for confirmation of gas type if you are in doubt.

### Installation of Consumer Piping

The gas supply (consumer piping), termination is inside the heater and enters through the rear of the appliance.

Refer to page 35 for appliance gas inlet location and other relevant dimensions.

Mark off the location for the vertical centre line ① of the heater enclosure.

To the right of the vertical centre line ①, mark off both the vertical ② and horizontal ③ location for the gas supply penetration (consumer piping). For measurements refer to the Gas Supply Dimension Table below.

The length of the gas supply (consumer piping) termination ④ is measured from the front of the enclosure.

**Gas Supply Dimension Table**

②	310mm to the right of the appliance centre-line
③	35mm from base of enclosure
④	Consumer piping to be terminated 230 mm from the front of enclosure.

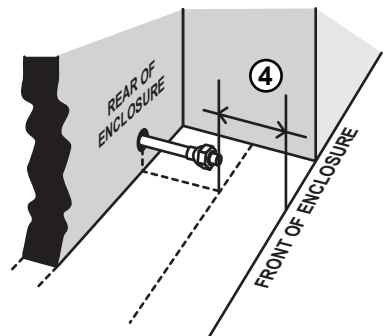
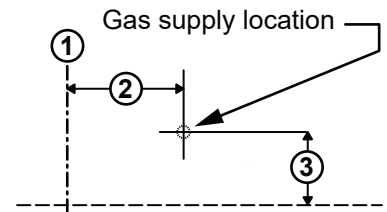

Masonry fireplace installations: Gas supply dimension ④ **MUST** include the thickness of infill panel (when fitted). A standard Rinnai infill panel adds 2mm to the front of the enclosure.

False fireplace installations: Gas supply dimension ④ **MUST** include thickness of the cladding used.

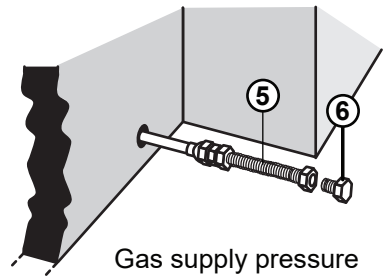

Gas supply pressure to be 1.13 to 2.75 kPa

Once the consumer piping has been terminated the supplied flexible gas connection ⑤ may then be fitted.

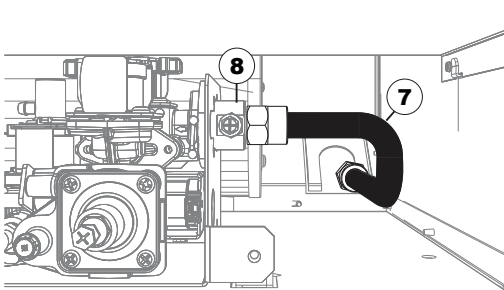

### Gas Connection

Firmly grasp the stainless steel flexi pipe ⑦ and bend to line up with the gas control valve inlet ⑧, then attach the pipe to the gas control valve and tighten.

### Purging Gas Supply

Foreign materials and debris such as swarf, filings, etc. **MUST** be purged/removed from the gas supply, failure to do so may cause damage to the gas control valve causing it to malfunction.

### Leak Testing the Connection

With the supplied plug ⑥ inserted into the end of the flexible gas connection, leak test all joints.



Use a soapy solution to test all gas connections. If a leak is present bubbles will form. When finished remove residue with a rag. Prevent soapy solution from contacting electrical components.

ELECTRICAL SUPPLY

**HAZARDOUS VOLTAGE. Risk of Electrical Shock.** Disconnect all sources of supply prior to servicing

**Socket Outlet**

Where a power point is used it **MUST** be 230 V, rated at 10A and **MUST** be earthed. This power point **MUST NOT** be located above the heater. Alternatively the appliance can be direct wired if the power supply is to be concealed.

The heater engine is fitted with a 1.5 m power cord and three pin plug ⑨ which exits the appliance from the rear panel at the lower right when viewed from the rear.

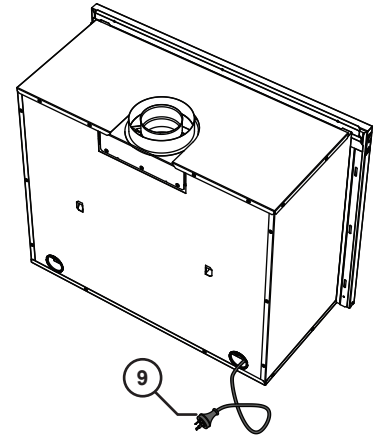

**Direct Wired Installations**

Alternatively the appliance can be direct wired if so required.

**IMPORTANT** A qualified electrician will need to be consulted where a direct wired installation is required. Any such installation **MUST** comply with the requirements of AS/NZS 5601, AS/NZS 3000 and any other relevant local regulations.

**False Fireplace Zero Clearance Cable Access**

An access flap ⑩ is provided to the LHS of the zero clearance box so installers can reach the power cord after feeding through the hole in the back panel.

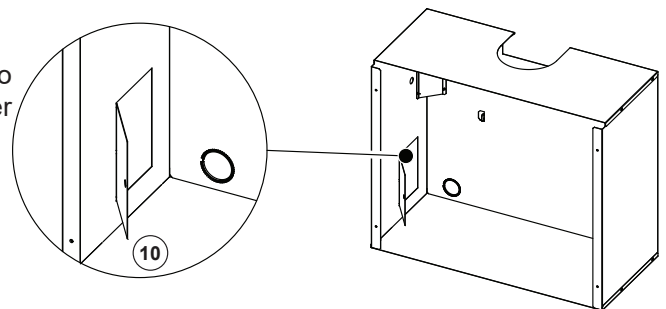

**Using an existing externally mounted power point**

If you already have an existing power point outside the enclosure, you can redirect the power cord through the LHS or RHS of the front panel. With the frame removed redirect the cord and plug (with the grommet), underneath the unit and to the front (left or right).

Remove the pre-punched metal knock-out ⑪ located in the lower left or right edge of the frame, ensuring the grommet is fitted to the metal knock-out. Excess cord may be left in the cavity below the unit—**DO NOT** coil excess cord.

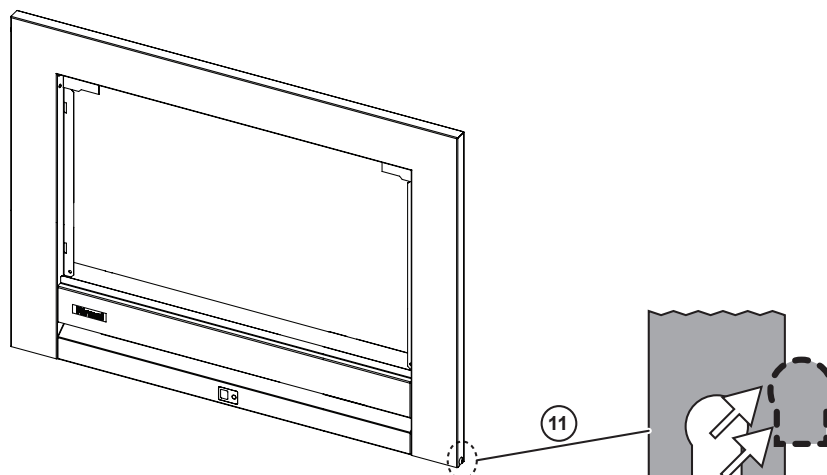

## GENERAL FLUEING GUIDELINES



The following diagrams illustrate the flue installation options that are available for the Rinnai SS850 Heaters. **ONLY** the genuine Rinnai flue is certified as part of the installation requirements.

**ONLY** an authorised person **MUST** install, service and remove the Rinnai SS850 and heater and flue system.

Only the flue system components described in this Manual are suitable and **MUST** be used. **‘DO NOT USE AN UNLINED MASONRY CHIMNEY AS THE FLUE FOR THIS APPLIANCE’**.

Components that are not described in that manual, whether manufactured by Rinnai or otherwise, are **NOT** compatible and **MUST NOT** be used.

Rinnai appliance warranty conditions may be voided if non Rinnai Flue Components are fitted.

AS/NZS 5601 “GAS INSTALLATIONS” requires that flue components be supported independently of the appliance.

### Flueing options for the SS850 depending on the installation:

- False Fireplace - coaxial flueing
- Masonry colinear flueing  
Flexible aluminium flues that come directly off the fire.

### Self-supporting flue - False Fireplace

The weight of the flue system should not be supported by the appliance. It should be self-supporting.

Supporting the flue is usually completed during the framing stage with flue supports or straps within the cavity. Wall straps have been included in the Rinnai coaxial vertical flue kit. Elbow straps are also available as a separate component to prevent excess weight on the flue elbow (if used).

### Flue terminal locations

Flue terminals must be compliant with the flue terminal locations shown in AS/NZS 5601.1.

The flue cannot terminate under a floor or in a roof space.

### Flue cowl clearance

To ensure products of combustion are cleared, adequate clearance from the building is required.

The flue cowl should have a 500 mm clearance from any part of the building. This also applies to steeped and pitched roofs where the flue cowl should be 500 mm clear of the ridge line.

An adequate flow of fresh air must exist around the flue cowl following installation.

Minimum clearances are shown in AS/NS 5601.1

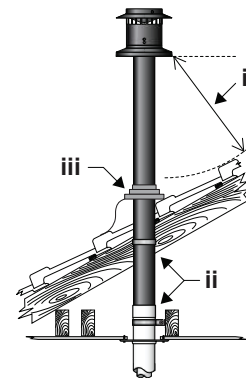

### Shared flues



Gas appliances must not be connected to a chimney or flue serving a separate flue burning appliance.

## FLUEING OPTION: MASONRY

### Vertical Colinear flexi flues with Duravent cowl - 850FLEX and 850CLFLEX

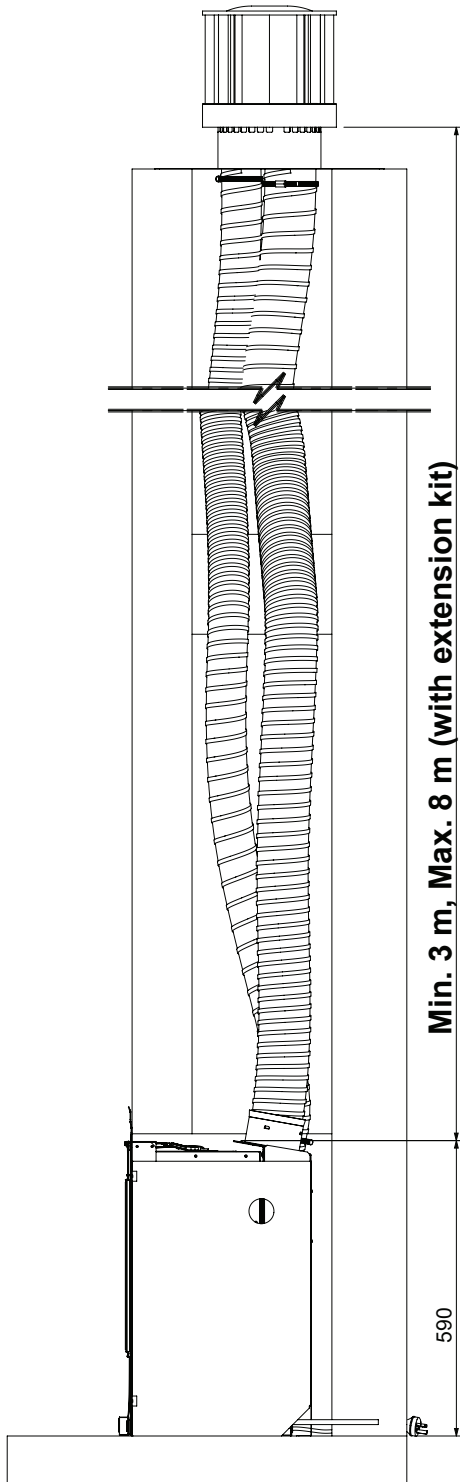

#### Masonry vertical flexi flue kit 5.5 m DV

##### 850FLEX

For installations in a masonry fireplace. Extends out to 5.5 m. If longer flueing is required then the colinear flexi flue extension kit needs to be ordered.

##### Kit includes:

- aluminium colinear roof cowl DV
- chimney plate 455 x 455 mm
- intake flexi Ø75 mm (LHS)
- exhaust flexi Ø100 mm (RHS)
- 4 x Ø100 mm flue clamps stainless steel

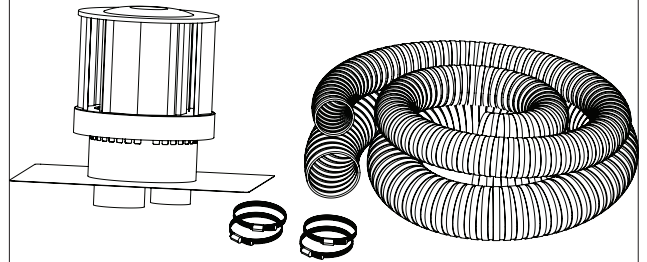

#### Masonry vertical flexi flue ext kit 2.5 m

##### 850CLFLEX

When flueing needs to extend beyond 5.5 m.

##### Kit includes:

- intake flexi Ø75 mm (LHS)
- exhaust flexi Ø100 mm (RHS)
- 2 x joiners
- 4 x Ø100 mm flue clamps stainless steel

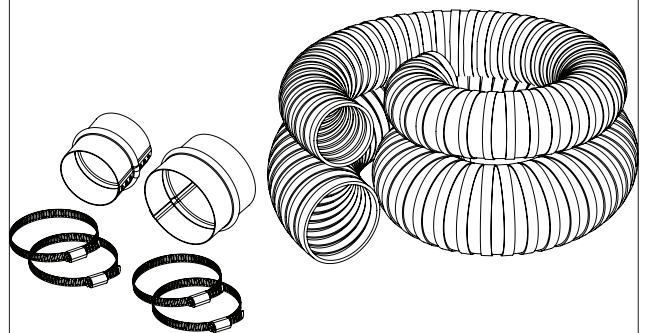

#### High wind areas

If located in a windy areas, then a DV high wind vertical cowl protection kit (RDB992) is recommended. It is designed to wrap around the vertical flue cowl to reduce wind entering the flue and causing flame disturbances. Refer page 17 for more information.

**FLUEING OPTION: FALSE FIREPLACE**

**Vertical Coaxial flue with Duravent cowl**

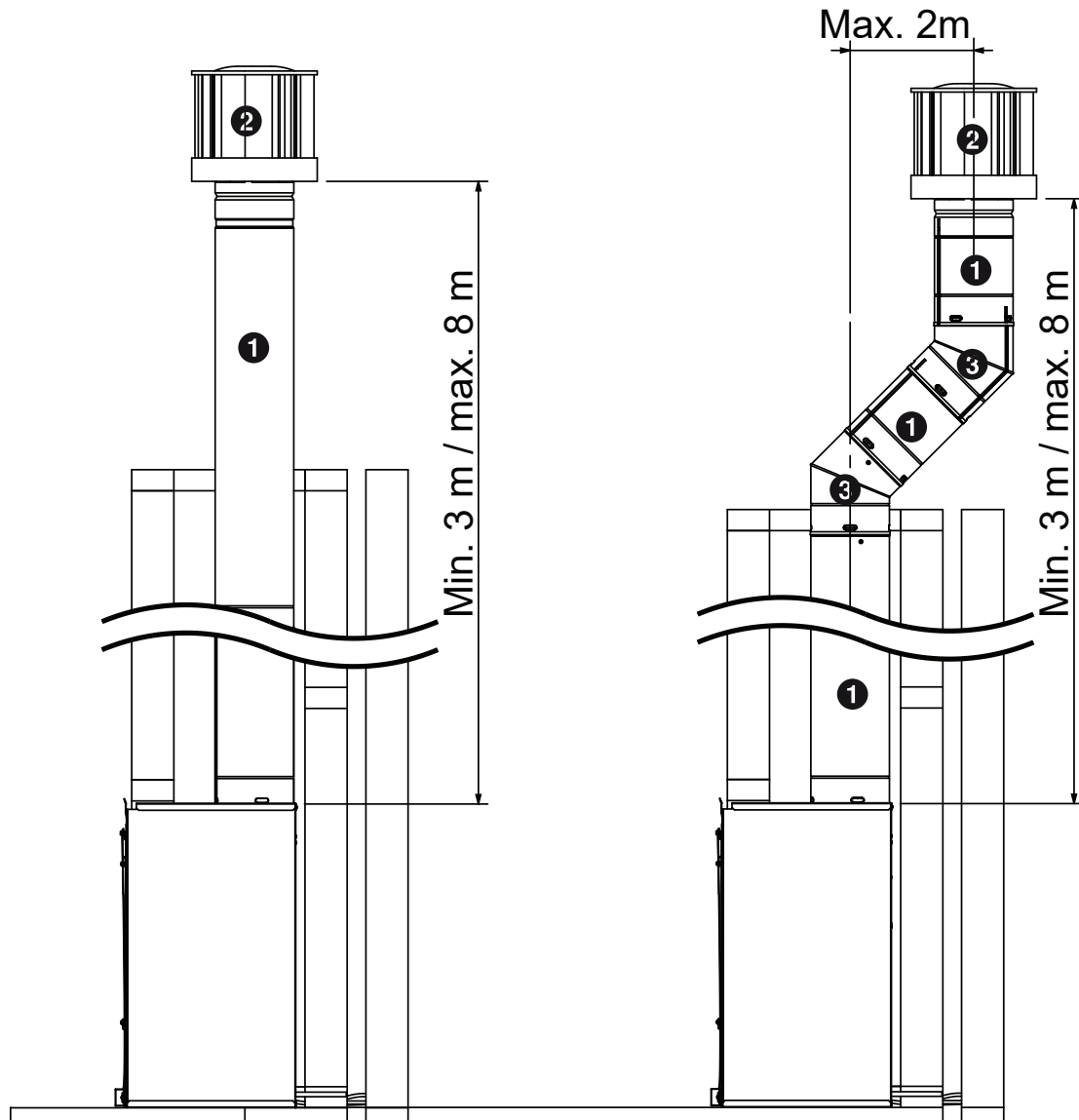

**Straight vertical flueing**

When installing a short vertical flue (no bends) for a single storey dwelling, the False Fireplace the 3.6m vertical flue kit (RDVSV or RDVSVB) can be used. Otherwise the flue components can be ordered separately.

①	Flue pipe(s) or flue extension.
②	Roof cowl (RDV991)
③	Flue elbow 45 ° (RDV945G), maximum number of bends is two

**High wind areas**

If located in a windy areas, then a DV high wind vertical cowl protection kit (RDB992) is recommended. It is designed to wrap around the vertical flue cowl to reduce wind entering the flue and causing flame disturbances. Refer page 17 for more information.

**FLUE COMPONENTS**

**Coaxial vertical flue kit  
3.6 m**

- RDVSV (Galv. Steel)
- RDVSVB (Black)

**Kit includes:**

- Coaxial vertical roof cowl (RDV991)
- 3 x 1200 mm flue pipes (RDV902)
- 2 x wall straps (RDV954)

If longer flueing is required order additional lengths of flue pipe.

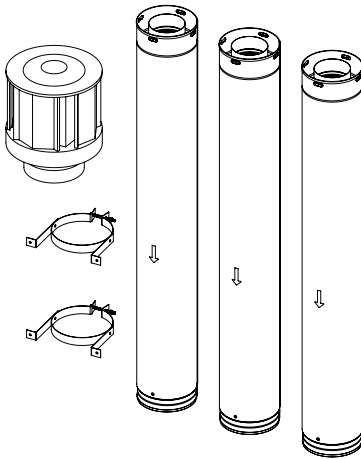

**Coaxial vertical flue  
cowl**

RDV991

Aluminium flue terminal required for all coaxial vertical flue installations—part of vertical flue kit.

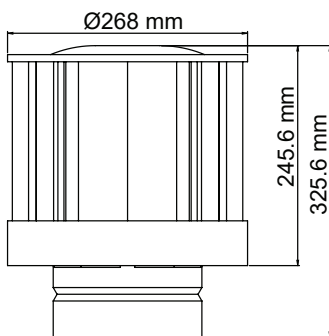

**Flue pipe extensions  
75-360 mm**

RDV911

Used for extended straight lengths of flue. Available in two lengths—extending to 175 mm or 360 mm. **CANNOT** be cut to size.

Inner: Aluminium Ø100 mm  
Outer: Galv. steel Ø170 mm

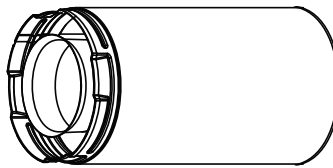

**Coaxial 45° flue elbows**

RDV945G

- **One elbow in a kit.**

Offsets obstructions. Elbow swivels 360° at base. Angle not adjustable. Once joined effective length reduces 35 mm to approx. 73 mm.

Inner: Aluminium Ø100 mm  
Outer: Galv. steel Ø170 mm

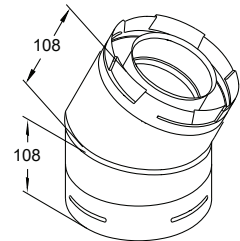

**Coaxial flue pipes DV**

CANNOT be cut to size.

Once joined nominal length reduces approximately 35 mm.

Inner: Aluminium (Ø100 mm)

Outer: Galvanised steel (Ø170 mm)

230 mm	RDV907
300 mm	RDV906
600 mm	RDV904
900 mm	RDV903
1200 mm	RDV902

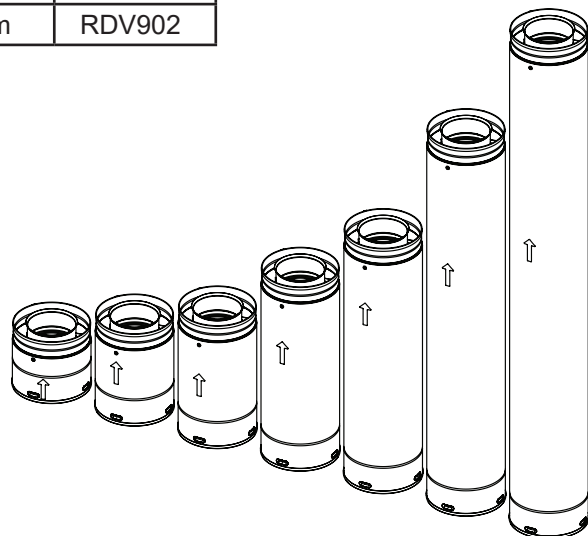

**Flue Components (Cont)**

**Wall strap DV**

RDV954

Adjustable strap used in installations to add lateral support to the flue.

Provides a 50-200 mm clearance to combustibles.

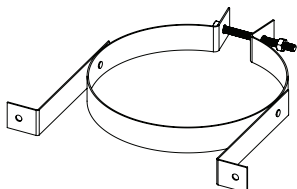

**Elbow flue strap DV**

RDV951

Flue supports for elbows and offsets. Strap length approximately 432 mm.

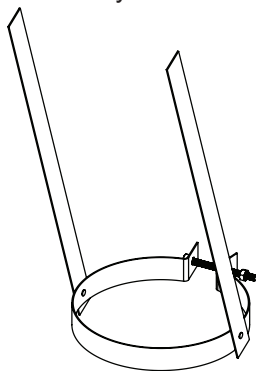

**High wind vertical cowl protection kit**

RDB992

Designed to wrap around the vertical cowl (as pictured) to reduce wind entering the flue and causing disturbances. It is fitted to the cowl and can be retrofitted.

Construction - stainless steel

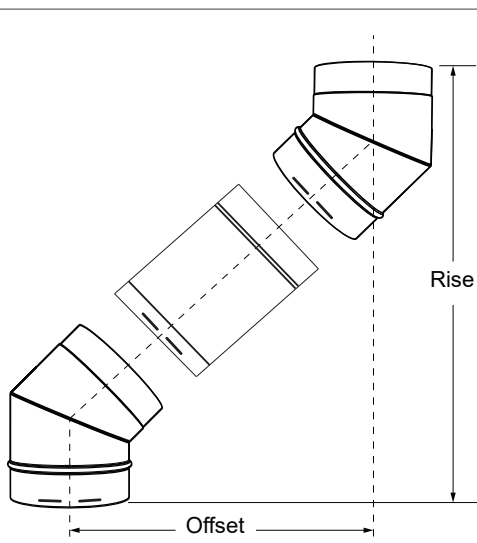
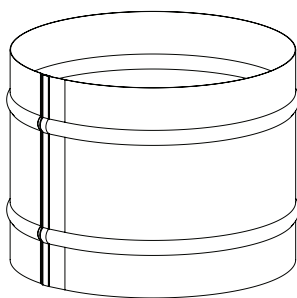

Flue pipe (length and code)		Offset	Rise
None (bend to bend)	N/A	124 mm	340 mm
230 mm	RDV907	257 mm	473 mm
300 mm	RDV906	311 mm	527 mm
600 mm	RDV904	524 mm	740 mm
900 mm	RDV903	737 mm	953 mm
1200 mm	RDV902	949 mm	1165 mm

**FLUE INSTALLATION DIMENSIONS & RESTRICTIONS FLUE TERMINAL CLEARANCES**

**Flue Terminal Clearances (extract from AS/NZS 5601)**

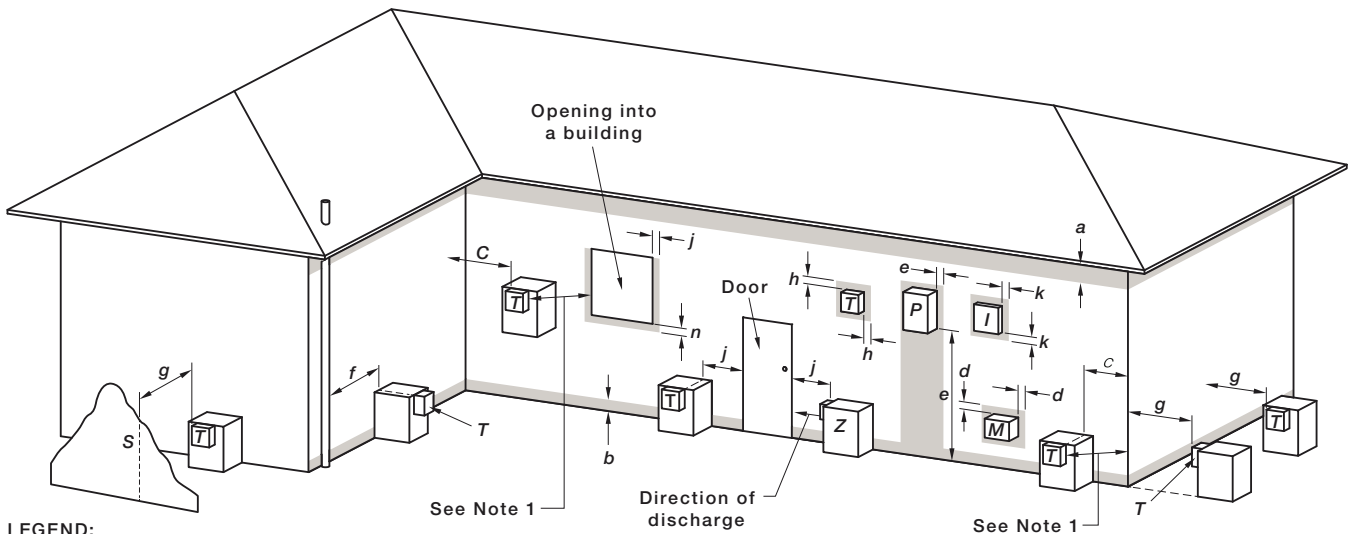

**LEGEND:**

- I = Mechanical air inlet
- M = Gas meter
- P = Electricity meter or fuse box
- S = Structure
- T = Flue terminal
- Z = Fan-assisted appliance only

■ Shading indicates prohibited area for flue terminals

Ref.	Item	Min. Clearances (mm)
		Natural Draught
a	Below eaves, balconies and other projections:	
	• Appliances up to 50 MJ/h input	300
	• Appliances over 50 MJ/h input	500
b	From the ground, above a balcony or other surface *	300
c	Front a return wall or external corner *	500
d	From a gas meter (M) (see 5.11.5.9 for vent terminal location of regulator) (see Table 6.6 for New Zealand requirements)	1000
e	From an electricity meter or fuse box (P) †	500
f	From a drain pipe or soil pipe	150
g	Horizontally from any building structure* = or obstruction facing a terminal	500
h	From any other flue terminal, cowl, or combustion air intake †	500
j	Horizontally from an openable window, door, non-mechanical air inlet, or any other opening into a building with the exception of sub-floor ventilation:	
	• Appliances up to 150 MJ/h input *	500
	• Appliances over 150 MJ/h input up to 200 MJ/h input *	1500
	• Appliances over 200 MJ/h input up to 250 MJ/h input *	1500
	• Appliances over 250 MJ/h input *	1500
	• All fan-assisted flue appliances, in the direction of discharge	-
k	From a mechanical air inlet, including a spa blower	1500
n	Vertically below an openable window, non-mechanical air inlet, or any other opening into a building with the exception of sub-floor ventilation:	
	• Space heaters up to 50 MJ/hr input	150
	• Other appliances up to 50 MJ/hr input	500
	• Appliances over 50 MJ/h input and up to 150 MJ/h input	1000
	• Appliances over 150 MJ/h input	1500

\* - unless appliance is certified for closer installation

† - Prohibited area below electricity meter or fuse box extends to ground level.

**NOTES:**

- 1 Where dimensions c, j or k cannot be achieved an equivalent horizontal distance measured diagonally from the nearest discharge point of the terminal to the opening may be deemed by the Technical Regulator to comply.
- 2 See Clause 6.9.4 for restrictions on a flue terminal under a covered area.
- 3 See Figure J3 for clearances required from a flue terminal to an LP Gas cylinder. A flue terminal is considered to be a source of ignition.
- 4 For appliances not addressed above acceptance should be obtained from the Technical Regulator.

FIGURE 6.2 (in-part) MINIMUM CLEARANCES REQUIRED FOR FAN-ASSISTED FLUE TERMINALS, ROOM-SEALED APPLIANCE TERMINALS AND OPENINGS OF OUTDOOR APPLIANCES

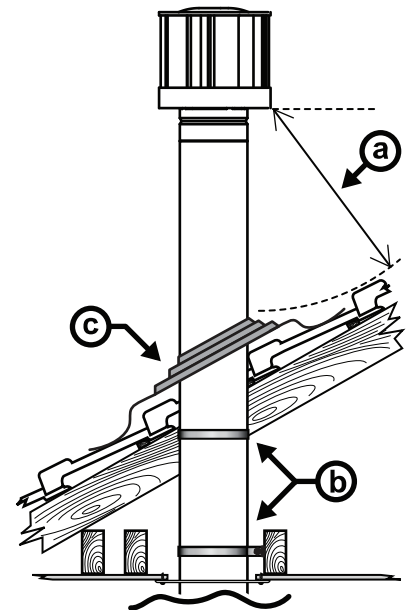

- Ⓐ Minimum clearance 500 mm to nearest part of roof.
- Ⓑ Minimum clearance 25 mm to combustible materials.
- Ⓒ Decktite or lead collar flashing.



**This appliance is a natural draft appliance and does not contain a combustion fan.**

## FALSE FIREPLACE INSTALLATION



When installing the Rinnai SS850 into a purpose built false fireplace, which is not open to the roof space of the building, cavity vents will need to be added.

Heat lost through the outer skin of the appliance and flue system may not adequately vent. This can lead to excess heat in the cavity. In some cases the fire may overheat and the safety mechanisms may operate.

Adding two vents of at least 200 cm<sup>2</sup> one at floor level and one at ceiling level, will allow adequate airflow in a cavity of approximately 1.2 m wide x 2.4 m high and 0.8 m deep.

### 1. Modify the enclosure:

Ensure the enclosure meets the requirements set out on "Enclosure Requirements" on page 10.

### 2. Gas and electrical connections:

Prepare gas and electrical connections, refer page 11-12.

### 3. Take the Zero Clearance Box (ZCB) and coaxial flue adapter off the engine

The Zero Clearance Box and flue adapter come assembled on the engine and need to be taken off.

- (i) Lift and remove the inner frame.
- (ii) Remove the two screws holding the outer frame to the fire—lift and remove.
- (iii) Disconnect the CAT5 cable from the ON/OFF button.
- (iv) Remove the screws securing the Zero Clearance Box and slide the engine out
- (v) Remove the four screws holding the flue adapter to the Zero Clearance Box and set aside.

### 4. Install the Zero Clearance Box into the enclosure

Fit the Zero Clearance Box. The base must be flat and level. Front flange to be set forward to allow the wall lining and flange to be flush when finished. Fit the Zero Clearance Box to the framing on the side and top, use packers to ensure the screws do not deform the panels of the Zero Clearance Box.

### 5. Install the coaxial flue adapter

Slide the flue adapter up and in place using the support tags on the back of the Zero Clearance Box. Fix in place using four screws through the air inlet ports.

### 6. Install flue system:

Install coaxial flue system. Ensure it is self supported.

### 7. Connect flue to flue adapter

Slide the flue into the spigot of the flue adapter and push down until it is clipped in place.

### 8. Check engine seals and determine flue length

Ensure the rubber seals fitted to the back of the fire are in place. Also determine flue length and aeration plate configuration, refer page 23.

### 9. Slide engine into the cavity

Slide fire into the cavity until the front flange of the fire is sitting flush against the flange of the Zero Clearance Box. When aligned the red exhaust seal goes straight into the hole, and the four holes of the coaxial adapter and engine line up. Fix the fire to the Zero Clearance Box (four screws) and use outer slots to secure to the enclosure.

Once the fire has been screwed to the zero clearance box, the front face of the frame and the front flange of the fire should be pulled up hard against each other. There are witness holes in the front flange of the fire to ensure this happens, refer image on page 24.

It is critical to ensure that the air and flue seals are correctly compressed. If there is a gap present, there may not be a proper seal and performance could be affected.

### 10. Complete gas connection

### 11. Install the burn media and commission

Install the burn media, refer page 25. Refit the glass and the inner and outer frames.

**False Fireplace Installation Overview:**



False Fireplace enclosure



SS850 with Zero Clearance Box and adapter removed

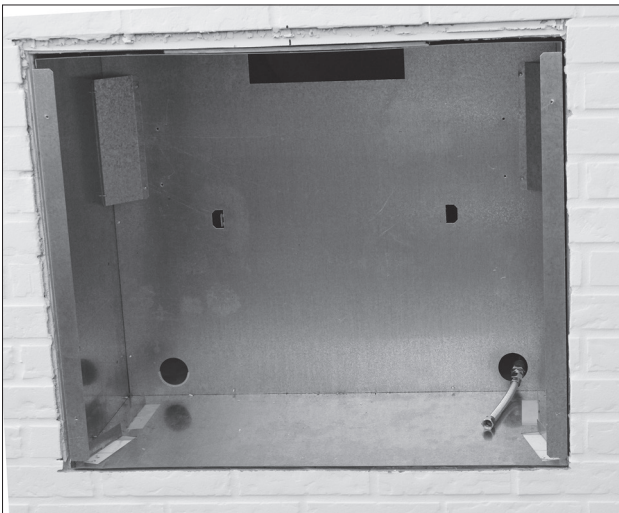

Zero Clearance Box installed



Zero Clearance Box and coaxial flue adapter

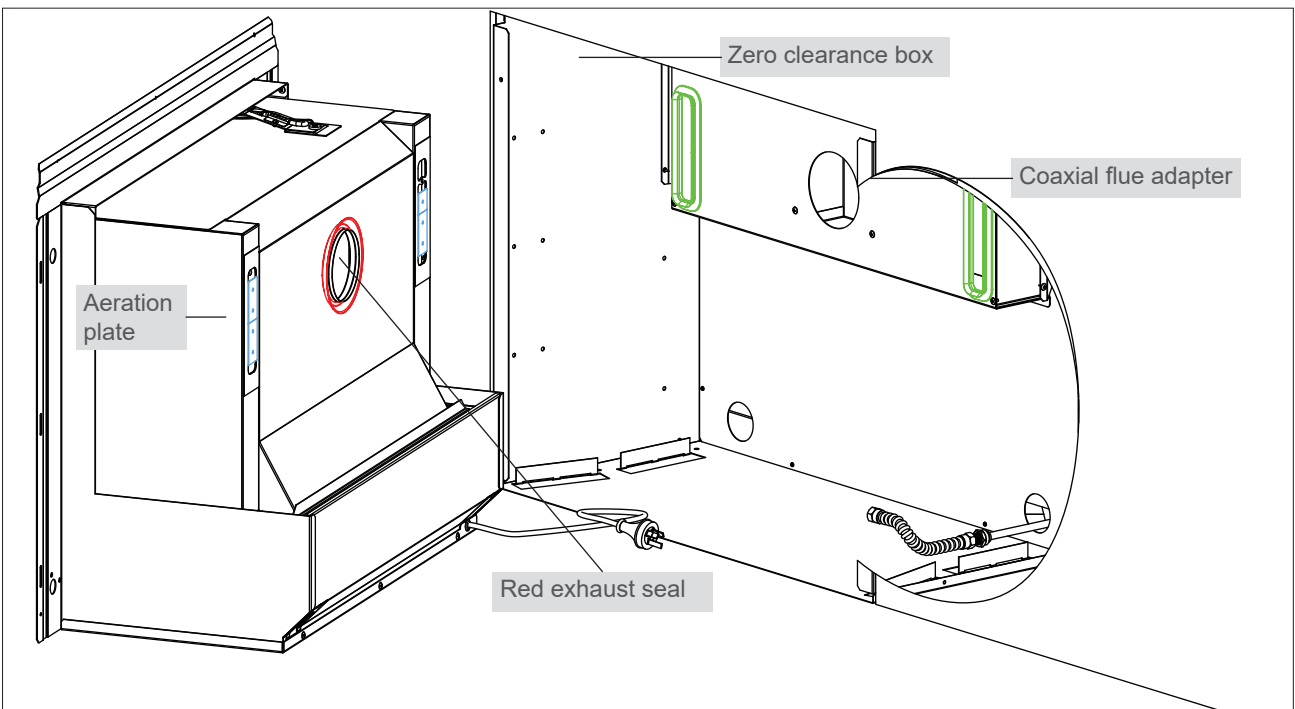

**MASONRY INSTALLATION**

In a masonry fireplace use a slurry of sand and cement to level the base as required.

**1. Modify the enclosure:**

Ensure the enclosure meets the requirements set out on page 10.

**2. Gas and electrical connections:**

Prepare gas and electrical connections, refer page 11-12

**3. Take the masonry adapter frame and colinear flue adapter off the engine**

The adapter frame and flue adapter come assembled on the engine and need to be taken off.

- (i) Lift and remove the inner frame.
- (ii) Remove the two screws holding the outer frame to the fire—lift and remove.
- (iii) Disconnect the CAT5 cable from the ON/OFF button.
- (iv) Remove the screws holding the fire to the adapter frame and slide the engine out of the box
- (v) Remove the four screws holding the flue adapter to the adapter frame and set aside.

**4. Install the masonry adapter frame into the enclosure**

Fit the adapter frame into the enclosure, base must be flat and level, and the notch in the back panel to be in line with the centre of the cavity. Fix in place through two holes in the back panel.

**5. Connect flexi to flue terminal and drop flexi flues down the chimney**

Stretch out the flexi to the required length and attach to the flue terminal using the clamps provided. Fix flue terminal in place, allow enough flue in the cavity to fix the flue adapter.

**6. Connect flexi flues to the colinear flue adapter**

Place the flue adapter in the cavity, it can be on the floor while attaching the flues. Attach the air intake flue over the spigot, place the flue clamp over the flue and tighten. DO NOT overtighten as this will crush and damage the flue. Drill through the pre-punched holes either side of the clamp, and into the flexi flue spigot. Secure using the stainless steel self tapping screws provided, ensuring connection will stop movement or dislodgement of the flue.

Slide the exhaust flue into the spigot and push down until it is clipped in place

**7. Secure flue adapter to the adapter frame**

Lift adapter box into place and rest in support tags in the back panel. Fit to the back panel using four screws through the air inlet ports.

**8. Check engine seals and determine flue length**

Ensure the rubber seals fitted to the back of the fire are in place. Also determine flue length and aeration plate configuration, refer page 23.

**9. Slide engine into the cavity**

Slide fire into the cavity until the front flange of the fire is sitting flush against the flanges of the support panels. When properly aligned the red exhaust seal goes straight into the hole, and the four holes of the adapter frame and engine line up. Fix the fire to the adapter frame (four screws) and use the outer slots to fix the fire to the enclosure.

Once the fire has been screwed to the adapter frame, the front face of the frame and the front flange of the fire should be pulled up hard against each other. There are witness holes in the front flange of the fire to ensure this happens, refer image on page 24.

It is critical to ensure that the air and flue seals are correctly compressed. If there is a gap there may not be a proper seal and performance could be affected.

**10. Complete gas connection****11. Install the burn media and commission**

Install the burn media, refer page 25. Refit the glass and the inner and outer frames. If using an infill panel, refer separate instructions.

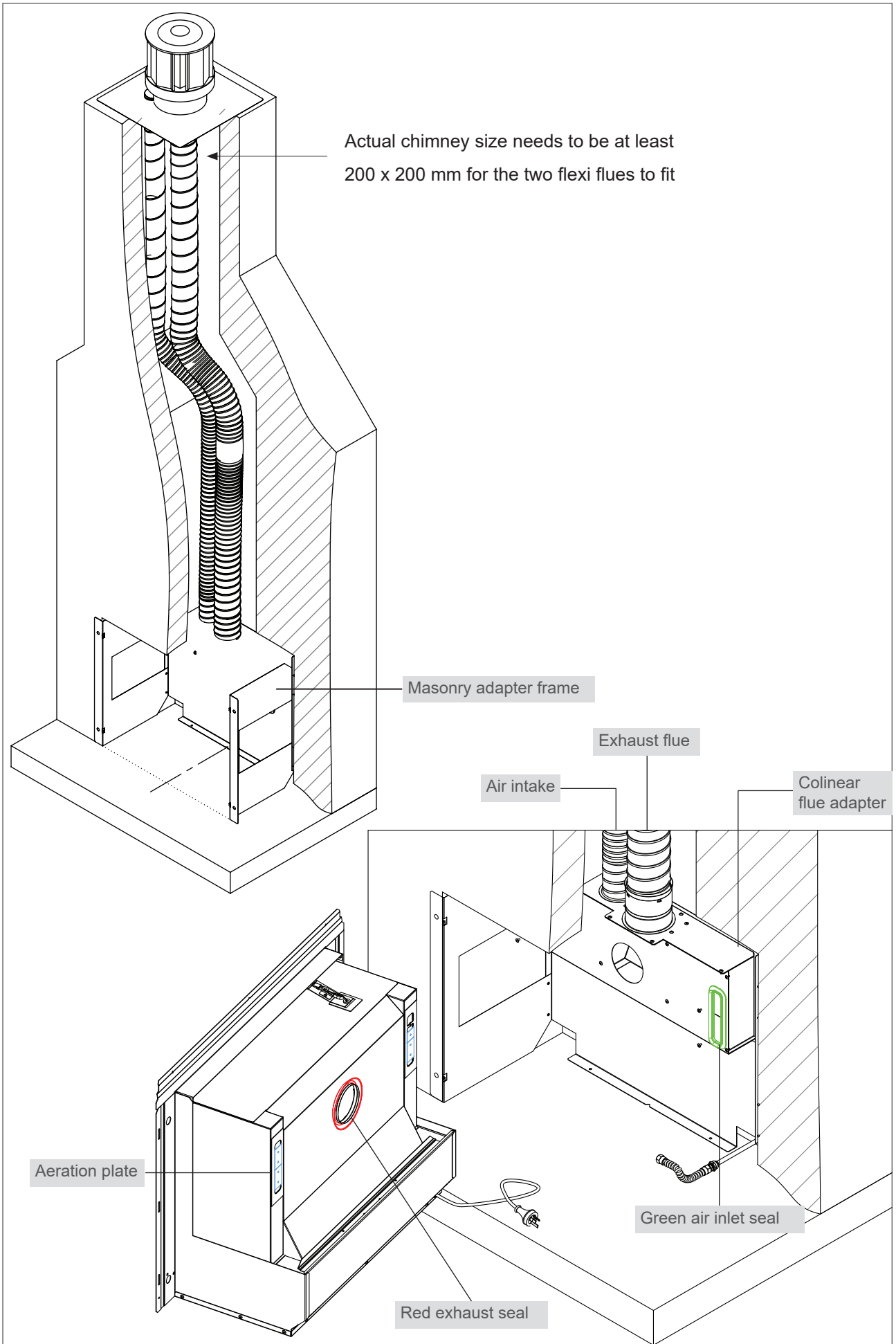

### AERATION PLATES

The SS850 comes with two aeration plates that are factory fitted, in a position for flues between 3-5.5 m, refer image below. There are a further two aeration plates supplied in the accessory pack (for flues 5.6-8 m).

To control flame lift and efficiency on long flues (anything over 3 m) it's important the aeration plates are configured correctly. Refer chart below.

To maintain balance within the combustion chamber, it is important to fit the plates equally to both sides of the fire. The chart below shows the plates required for any given flue length. Fitting more plates than shown may have a detrimental effect on startup performance, especially in very cold areas.

If the flue length is less than 3 m the factory fitted aeration plates need to be removed.

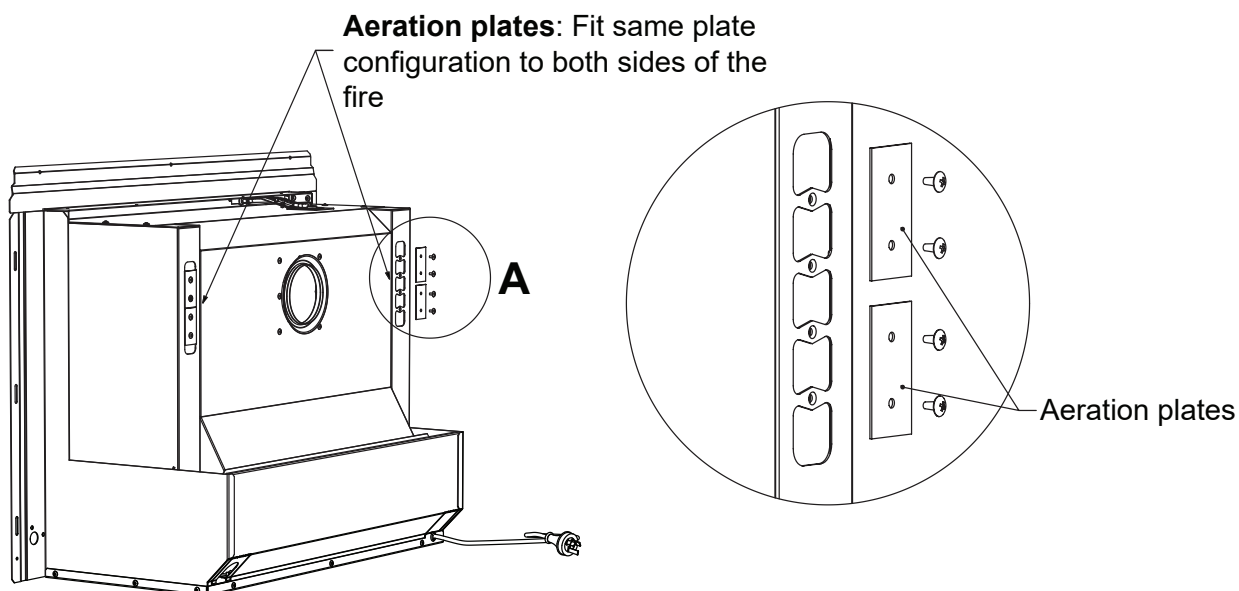

Vertical flue height	< 3 m	3 - 5.5 m	5.6-8 m
Action required	Remove factory fitted aeration plates	No action required	Fit additional plates supplied in accessory pack

**FIRE TO FLANGE CONNECTION**



The below installation step is common to masonry and false fireplace installations. It is **CRITICAL** to the safe operation of the fire.

Once the fire has been screwed to the zero clearance box or masonry adapter frame, the front face of the frame and the front flange of the fire should be pulled up hard against each other. There are witness holes in the front flange of the fire to ensure this happens.

It is critical to ensure that the air and flue seals are correctly compressed. If there is a gap present, there may not be a proper seal and performance could be affected.

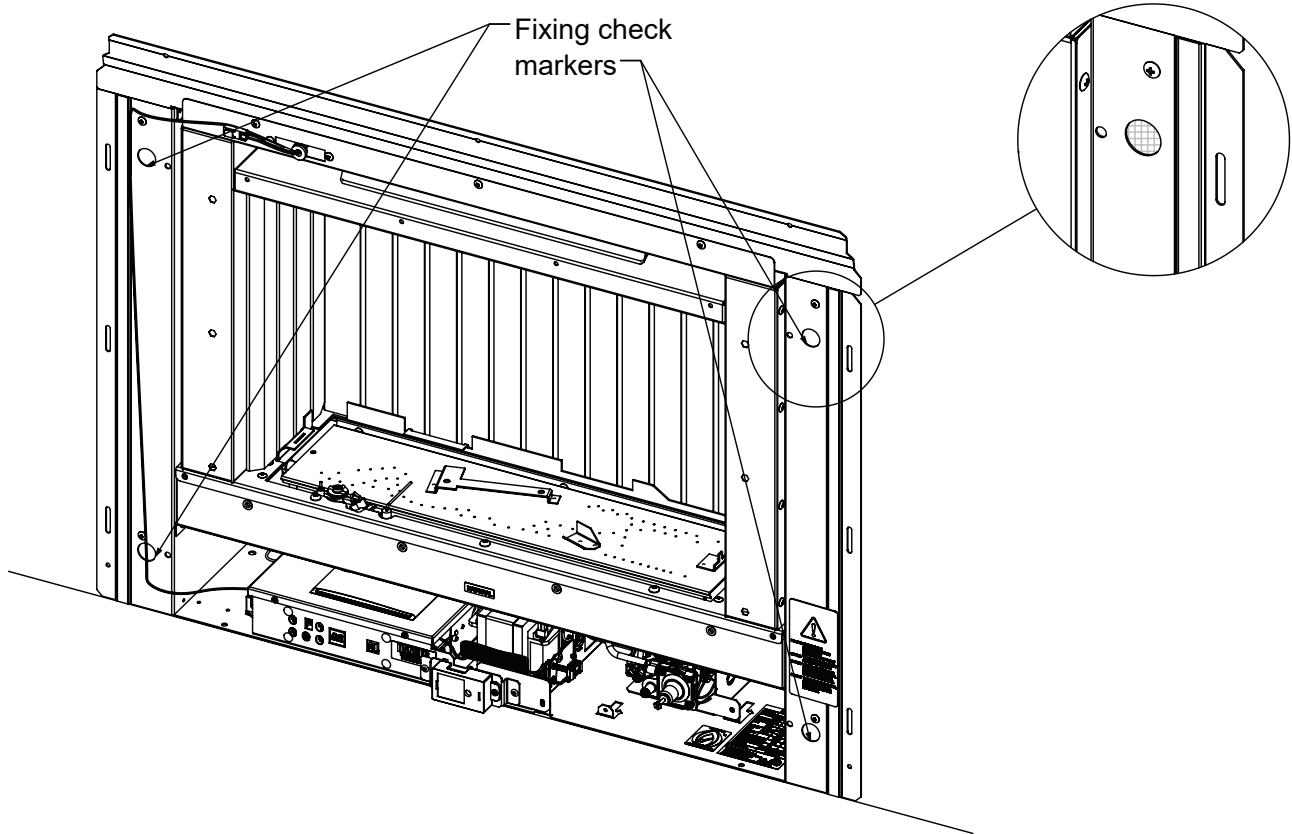

# BURNER MEDIA INSTALLATION

## BURNER MEDIA PLACEMENT

The granule pack and log set, consisting of five logs, comes packaged inside the appliance. Use extreme care when handling the logs, they are fragile and will damage easily. The unit must never be used with broken logs or other burn media.

Experience has shown that the majority of performance problems are caused by burn media being installed incorrectly. Incorrect placement can create carbon build-up and affect performance. Please take the time to read and follow these instructions as malfunctioning due to incorrect placement is not covered by warranty.

The granules as well as being added to create a more realistic log effect (they diffuse the gas flames) also assist in soot prevention and are **CRITICAL** to the correct operation of the fire. Never pour the granules directly from the pack as dust particles and the granules may block the burner ports.



During the initial burning in period of approximately 2 hours, some minor smoke and smell may be experienced. During this period the heater should be operated on High and the space being heated should be well ventilated. It may take up to 20 minutes of operation for the logs to achieve their full flame pattern and glow.

Malfunctions due to incorrect burn media placement are **NOT** covered by warranty.

The appliance **MUST NEVER** be used with other burn media or burn media that is damaged.



## BURNER MEDIA INSTALLATION

Arrange the rest of the logs and place 31 granules around the burner ports (not directly over) as shown below. You will have granules left over.

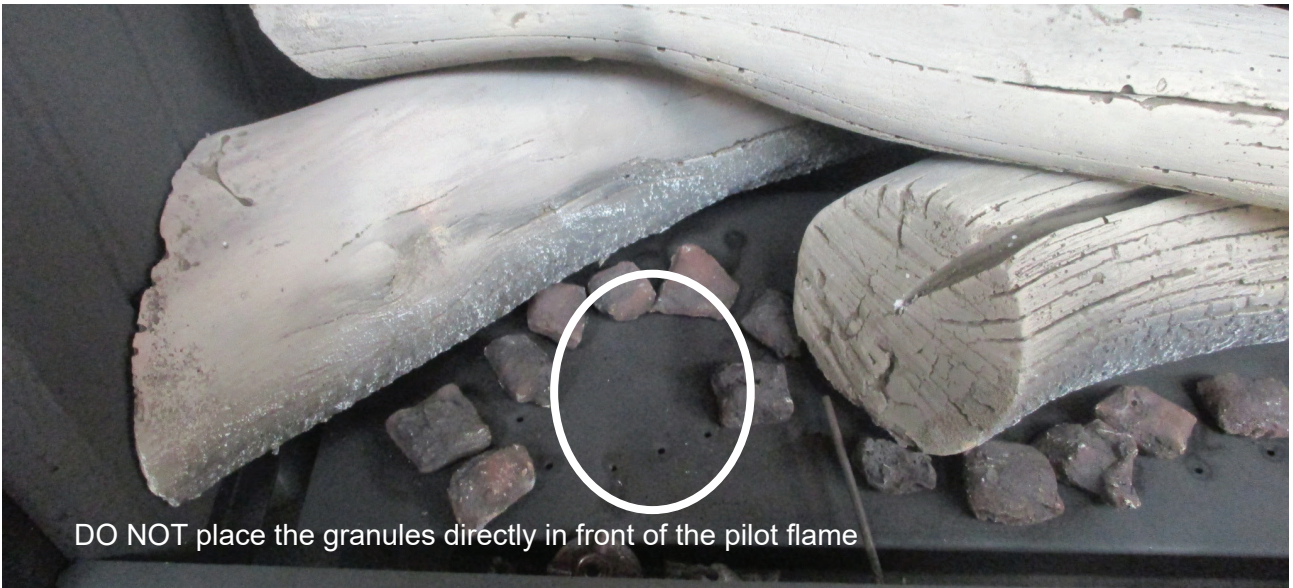
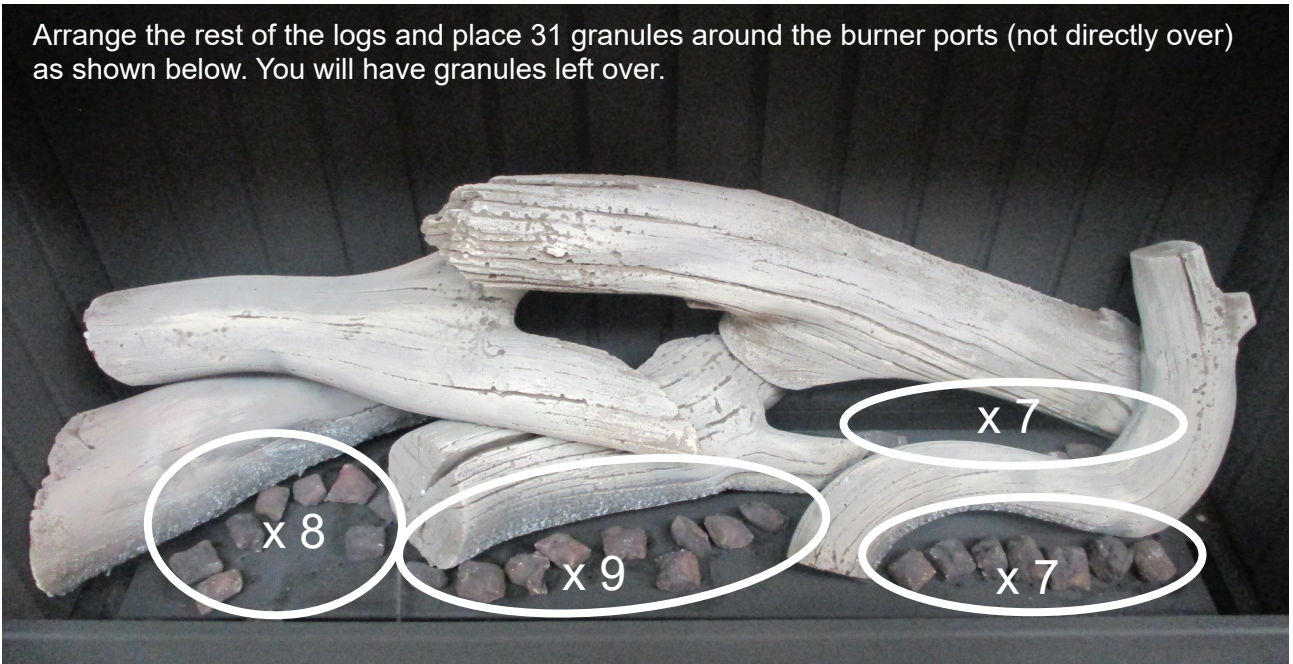

If there are some abnormally long streaky flames, then readjust the granule position around the burner holes until the flames have improved.

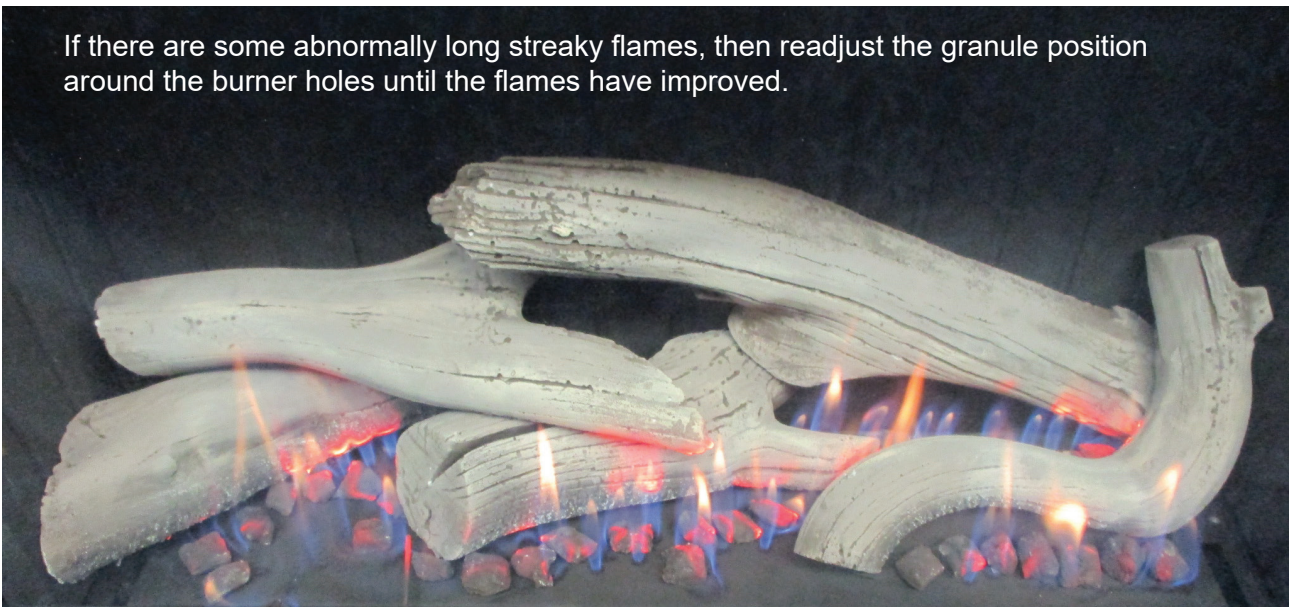

## GENERAL INFORMATION



**HAZARDOUS VOLTAGE.**  
**Risk of Electrical Shock.**



Disconnect all  
sources of supply  
prior to servicing



### Step 1. Unpack the Fascia

For commissioning, the control panel located on the fascia will need to be connected to the communication cable of the heater engine.

Remove all packaging materials and check all components for damage. If **ANY** damage is evident **DO NOT** install or operate this appliance. Contact your supplier for advice.

### Step 2. Connect Push Button Control

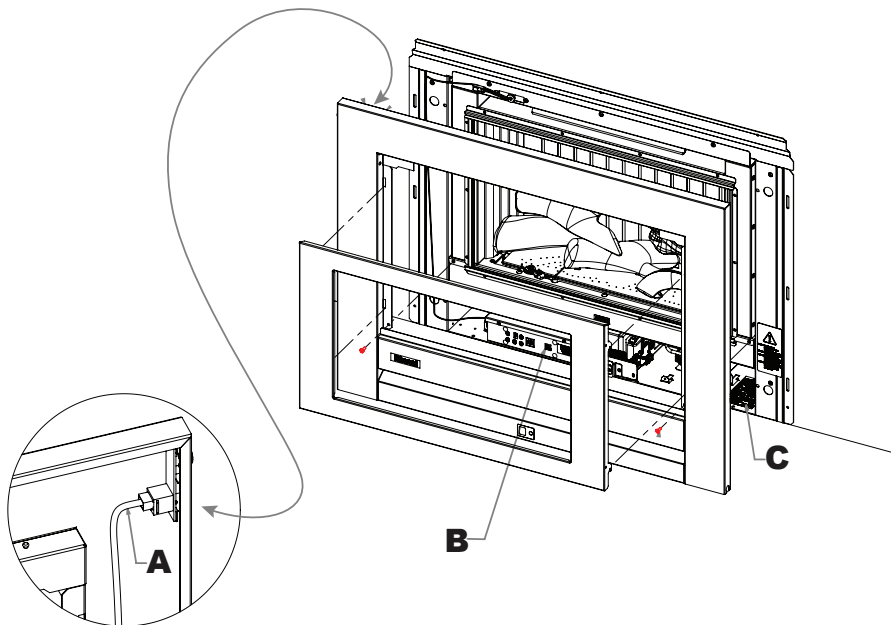

Carefully pick up fascia assembly, and position the fascia close to the heater engine.

Connect the RJ45 Cable and Plug **(A)** into the socket **(B)** located on the front of the heater (this connects the push button control panel via a communications cable to the heater engine's control box).

### Step 3. Switch on the Electricity Supply



**230 VOLTS, RISK OF ELECTRICAL SHOCK!**

Installation and commissioning **MUST** be carried out **ONLY** by an Authorised person.

Wiring inside this appliance may be at 230V potential, when performing the commissioning, the appliance electrical power will need to be connected. Exercise **CAUTION** as there is potential for electric shock from the exposed wiring and circuitry. **DO NOT** leave the appliance unattended when power is connected and the panels are removed.

### Step 4. Commission the Appliance



**DO NOT** test for gas leakage with an open flame.

The gas type codes and gas pressures for this appliance **MUST** be checked and set in accordance with these instructions when the appliance is installed, **OR** after the replacement of any component or reassembly after service.

Burner gas pressures and gas types are factory set.

The location of the gas control is in the air gap at the lower right hand side of the appliance.

The location of the data plate is on the base plate of the heater engine within the air gap on the right hand side of the appliance.



Gas supply pressure is to be checked with all other gas appliances in the household running on high. Failure to check this may result in lower than recommended required gas pressures, resulting in poor performance and reduced flame effect.

**Step 5. Checking Supply Pressure (Ensure gas is connected)**

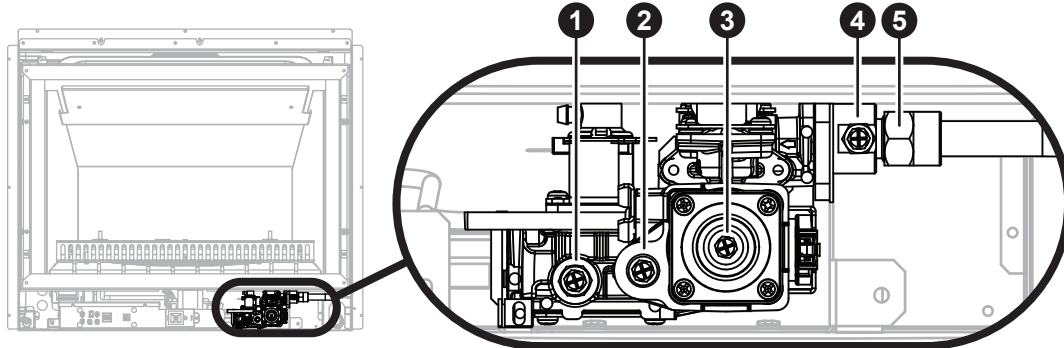

1. Remove the gas inlet test point screw ④, and connect the positive pressure manometer hose. Refer to valve drawing above.
2. Press the heater ON/OFF button ⑫, on the PCB control panel to start the ignition sequence. The appliance will ignite normally. Refer to PCB Control panel image below.

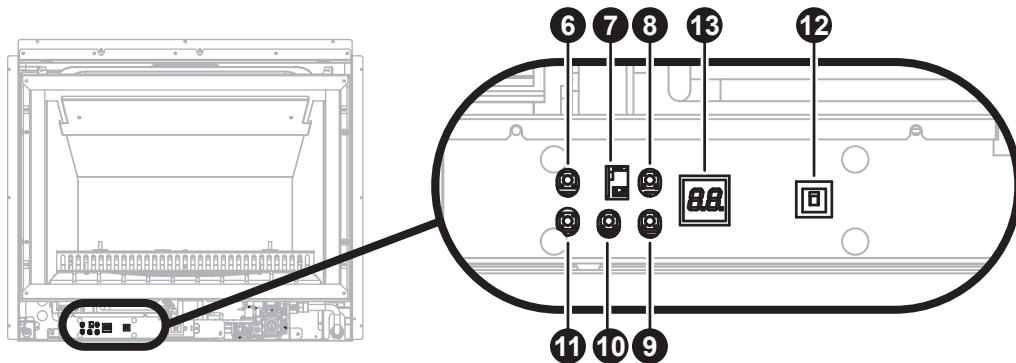

	Natural Gas	Propane Gas
Minimum Supply Pressure	1.13 kPa	2.50 kPa
Maximum Supply Pressure	3.50 kPa	3.00 kPa

*Refer to chart for the correct gas settings, (data plate values override values printed in this instruction).*

3. Check the pressures as per the chart below for the correct gas type. Ensure all other gas appliances in the household are running on 'High'
4. Press the heater ON/OFF button ⑫ to stop the appliance operation.
5. Disconnect the manometer hose and replace the inlet test point screw ④. Check for leaks using soapy water solution.

**Step 6. Checking and Setting burner gas pressure**

1. Remove the main burner test point screw ❶, and connect the positive pressure manometer hose.
2. Press the heater ON/OFF button ❷, on the PCB control panel to start the ignition sequence. The appliance will ignite normally. Refer to PCB Control panel image above.
3. Press the 'TEST' button ❸, twice on the PCB control panel, the igniter will spark and the appliance will light to its lowest setting, (Main burner - stage 1), and the display ❹, will show  $P_L$  (stage 1).
4. Press the 'UP' button ❺ or 'DOWN' button ❻ to adjust to the required value if values are different to those in the table below.

Model	Natural Gas		Propane Gas	
	SS850		SS850	
$P_L$ (stage 1)	0.20 kPa	0.20 kPa	0.50 kPa	0.50 kPa
$P_H$ (stage 7)	0.90 kPa	0.86 kPa	1.95 kPa	1.92 kPa

Refer to chart for the correct gas settings, (data plate values override values printed in this instruction).

5. Press the 'SET' button ❿, once to save the setting. The display ❹, should now be displaying  $P_H$ , (Main burner stage 7).
6. Press the 'UP' button ❺ or 'DOWN' button ❻ button to adjust to the required value, If the pressure is already correct or when the desired pressure is achieved press the 'SET' button ❿, once to save the setting.
7. The display ❹, will now show  $\bar{E}$ . If the display does not change to there was an error in pressure setting and the pressure setting procedure should be repeated from step 1 onward after turning the appliance 'OFF'
8. With the display ❹, showing  $\bar{E}$ . Press the heater ON/OFF button ❷.
9. Setting main burner pressure is now complete. Remove the manometer hose and replace the inlet test point screw ❶. Check for leaks using soapy water solution.

**Step 7. Checking and setting Pilot burner pressure**

1. Remove the pilot burner gas test point screw ❷, and connect a positive pressure manometer hose.
2. Press the heater ON/OFF button ❷ to start the ignition sequence, the appliance will ignite normally.
3. Press the 'TEST' button ❸, twice on the PCB control panel, the igniter will spark and the appliance will light to its lowest setting, (Main burner - stage 1), and the display ❹, will show  $P_L$ .
4. Adjust the pilot burner gas pressure to the value for the gas type as listed in the table below via the 'Pilot Burner Pressure Adjustment' screw ❸.

	Natural Gas	Propane Gas
Pilot Burner Pressure	1.00 kPa	2.00 kPa

Refer to chart for the correct gas settings, (data plate values override values printed in this instruction).

5. Press the heater ON/OFF button ❷, once to stop the appliance operation. Disconnect the manometer hose and replace the pilot burner gas test point screw ❷.
6. Check for gas leaks using soapy water, setting or checking pilot burner pressure is now complete.



**The requirements of AS / NZS 5601 include:**

- a. checking whether mechanical extraction ventilation draws air through flue systems or chimneys or not. If yes, this will most likely result in combustion product spillage from appliances during their operation.
- b. checking whether the operation of appliances and flue systems or chimneys is satisfactory.
- c. a method for determining the additional fixed ventilation area required to counteract the effect of mechanical extract ventilation.



**Always check gas pressure values to those recorded on this appliances data plate, values on the data plate override values printed in this instruction.**

**COMMISSIONING THE APPLIANCE FOR DIFFERENT GAS TYPE**



**230 VOLTS, RISK OF ELECTRICAL SHOCK!**

Installation and commissioning **MUST** be carried out **ONLY** by an Authorised person.

Wiring inside this appliance may be at 230V potential, when performing the commissioning, the appliance electrical power will need to be connected. Exercise **CAUTION** as there is potential for electric shock from the exposed wiring and circuitry. **DO NOT** leave the appliance unattended when power is connected and the panels are removed.

This appliance is factory set for the correct gas type as per its gas type labelling. Re-commissioning for gas type will only be required if the PCB is being replaced or if it has undergone a gas type conversion, i.e.; from NG to Propane or vice versa. Commissioning of the gas is carried out via the PCB.



Commissioning of the PCB **MUST** be carried out **BEFORE** the gas pressures are checked.

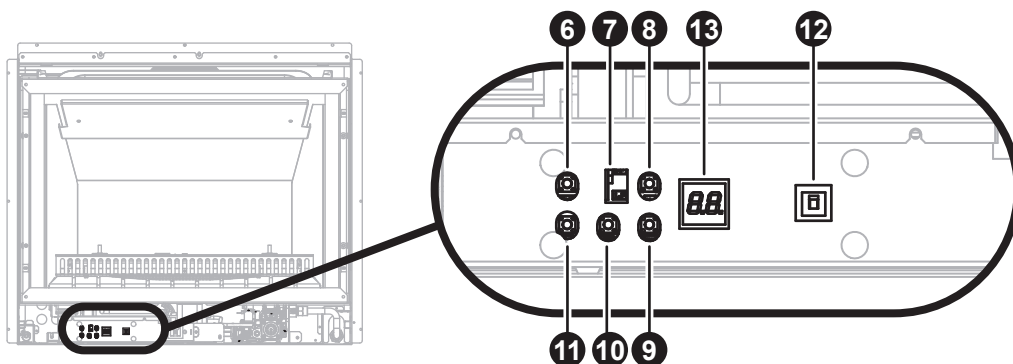

1. Turn on the gas and power supply to the appliance.
2. Press the 'UP' button or 'DOWN' button to obtain the correct gas type code for the appliance. Refer to chart to below for the correct gas type code.

Natural Gas	Propane Gas
A1	L1

3. With the appliance OFF, press the 'TEST' button, the gas type code will be shown on the display.
4. Press the 'SET' button, to lock in the code.
5. Gas pressure settings should now be checked as per "Step 7. Checking and setting Pilot burner pressure" on page 29, point 1 through 3.

## ATTACHING FASCIA ASSEMBLY

### Attach the Fascia to the Heater Engine

1. Ensure the CAT5 cable **(A)** is installed into the ON/OFF button on the frame and clipped in place in the front of the fire **(B)**.
2. Fit the frame over the top flange of the fire.
3. Fix the frame to the fire using the two supplied black M4 screws.



It is **CRITICAL** to the safe operation of the fire that these screws are in place (seals the fire).

4. Fit the inner frame to the fire by setting it into the allocated slot of the outer frame and sliding it down.
5. On the PCB control panel **(B)**, return the button to the ON position. Check the operation of the ON/OFF button on the frame and that the remote control is working.

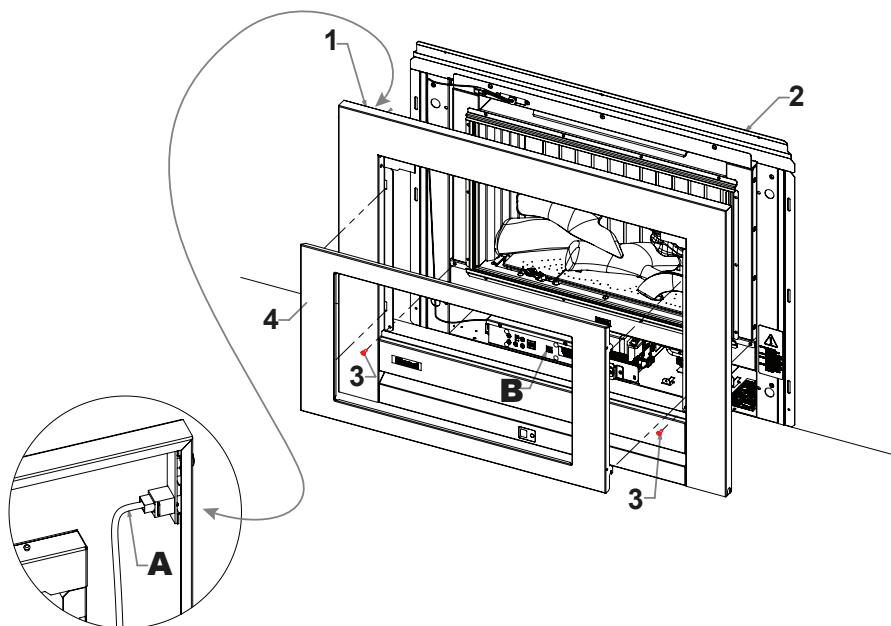

Ensure you **DO NOT** place excessive tension on or pinch the communication cable **(C)** when manoeuvring the fascia into position.



The glass of the fascia fitted to this appliance reduces the risk of fire and injury and no part of it should be permanently removed.

For protection of young children or the infirm a secondary guard is required.

**ABNORMAL FLAME PATTERN**

Each Rinnai Gas Fire has a distinct flame pattern. The flame should look the same every time you start your heater, after an initial warm up period of approximately 15 minutes.

Abnormal flame performance and/or pattern can indicate a problem with your heater, such as blocked gas injectors, incorrectly installed / inadequate flue system or the Ceramic logs / stones and or burner media may have shifted from when the heater was first installed.

There are some warning signs that could indicate a problem. If any of the signs below occur, please contact Rinnai.

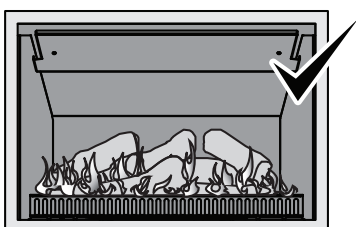

NORMAL FLAME PATTERN

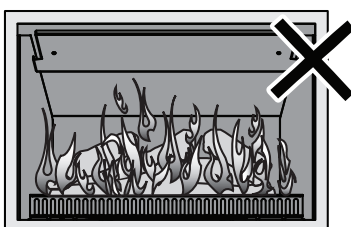

ABNORMAL FLAME PATTERN

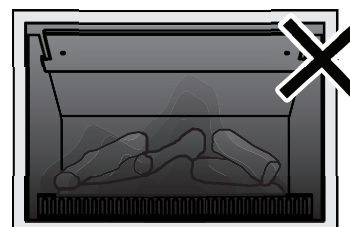

SOOT BUILD UP

**Key signs of abnormal flame performance:**

- Appliance turns 'OFF' soon after start up and does not relight.
- Continued difficulty or delay in establishing a flame
- Flame appears overly orange-yellow.
- Flame appears either very short or very long.
- Flame only burns part way across the burner.
- Severe soot building up on the inside of the glass or on logs.
- Continuous unusual smell from the appliance.
- Continued difficulty or delay in establishing a flame.



**This appliance incorporates a live fuel effect and is designed to operate with luminous flames. This may leave slight carbon deposition as part of its normal operation.**

# INSTALLATION CHECKLIST



It is the responsibility of the installer to complete both the "Installation Checklist" below and the "Installation Record" in the Operation Manual at the completion of installation.

Instruct customer on the heater operation and ensure the customer understands the content of the operation manual.



Advise the customer that during the initial burning period of approximately 2 hours, some smoke and odour may be experienced.

During this period the heater should be operated on 'High' and the space being heated should be well ventilated. It may take up to 20 minutes of operation for the logs to achieve their full flame pattern and glow.

Complete the "Installation Record" in the Operation Manual

**THE GUARD IS FITTED TO THIS APPLIANCE TO REDUCE THE RISK OF FIRE OR INJURY FROM BURNS AND NO PART OF IT SHOULD BE PERMANENTLY REMOVED.**

**FOR PROTECTION OF YOUNG CHILDREN OR THE INFIRM, A SECONDARY GUARD IS REQUIRED.**



The guard supplied with this appliance **MUST NOT** be permanently removed as it fulfils an operational safety function. Additional dress guards including free standing types may be used in conjunction with, but **NOT** replace, the dress guard supplied with this appliance.

The appliance is not intended for use by young children or infirm persons without supervision. Young children and the infirm **SHOULD** be supervised at all times when in the vicinity of this heater while it is in operation.

Ensure the Customer understands that:

- No part of this appliance should be permanently removed.
- Young children and the infirm should be supervised at all times.
- Paper or other material **MUST NOT** be burnt in this appliance.



The following checklist is to be completed **ONLY** by a Certified Gas Installer.

	<b>No</b>	<b>Yes</b>
1. Is the appliance positioned in a suitable location (clearances, combustible clearances, mantels and surrounds etc.)?	<input type="checkbox"/>	<input type="checkbox"/>
2. Was a Rinnai approved flue system installed and tested in accordance with the instructions?	<input type="checkbox"/>	<input type="checkbox"/>
3. Has the gas pressure been checked and set with all gas appliances running?	<input type="checkbox"/>	<input type="checkbox"/>
4. Has the log set / burn media been installed as per instructions?	<input type="checkbox"/>	<input type="checkbox"/>
5. Has the appliance tested for correct operation and to ensure no gas leaks?	<input type="checkbox"/>	<input type="checkbox"/>
6. Has combustion product spillage testing been conducted in accordance with AS/NZS5601?	<input type="checkbox"/>	<input type="checkbox"/>
7. Has the customer been instructed on operating procedure and safety requirements?	<input type="checkbox"/>	<input type="checkbox"/>
8. Is the end-user fully aware of operating procedure and has the manuals?	<input type="checkbox"/>	<input type="checkbox"/>
9. Has the Glass or Mesh Dress Guard been fitted?	<input type="checkbox"/>	<input type="checkbox"/>
10. Has the customer been advised not to remove the Dress Guard?	<input type="checkbox"/>	<input type="checkbox"/>
11. Has the customer been advised to service the heater every two years?	<input type="checkbox"/>	<input type="checkbox"/>

# SPECIFICATIONS

## APPLIANCE DETAILS

<b>Model</b>	<b>Rinnai SS850</b>
Features	Inbuilt Gas Space Heater Burning Log and Stone Fire Bed Effect Glass front Convection Fan, top warm air outlet Glass dress guard Infra Red (IR) remote control
Data Plate	Located on the lower RHS of the base panel in front of the gas control.
Input	14~30 MJ/h
Output (High)	6.6 kW*
Efficiency	77%
Heating area	65-112m <sup>2</sup> **
<i>Note: * will vary accordingly to gas type and flue configuration. ** will vary depending on geographical location.</i>	
Installation Types	Masonry Fireplace, False Fireplace, Inbuilt (weather proof box) and Standalone
Combustion Method	Bunsen type burner
Flue - Masonry	Co-linear flexi flue, air intake Ø75mm, exhaust Ø100mm. Appliance MUST BE installed with a Rinnai flue System.
Flueing - False Chimney	Co-linear (air intake Ø75mm, exhaust Ø100mm) to Coaxial direct vent flueing (inner Ø100mm, outer Ø170mm). Appliance must be installed with a Rinnai flue System.
Convection Fan	120V AC 50 Hz-2-speed centrifugal blower
Gas Connection	Brass 1/2" BSPT male fitting, the gas supply terminates inside the heater - lower right hand side of the appliance.
Gas Type	NG, Propane
Electrical	This heater has a 1.5 m power cord with a three pin plug supplied, the power cord passes through a slot in the back left hand corner of the appliance.
Ignition	230-240 V AC 50 Hz high voltage electronic spark ignition
Power Consumption	When on High, 115W When on Standby, less than 1W
Safety Devices	Overheat Switch Pressure relief on glass panel - burner box Thermal Fuse, over-current fuse Flame Failure Sensing System Refer to "SAFETY DEVICES" on page 7 of the Operation Manual for information regarding additional safety devices and features.
Glass - Primary Glass - Secondary Glass seal material	Ceramic Glass Tempered Glass Woven fibreglass chord
Weight (Engine Only)	51 Kg - "un-crated" - no Flue. 55 Kg - "un-crated" - no Flue.
Operation	Push button control panel, Infra Red Remote Control.
Noise Level	37~45 dB(A)



**Refer to appliance data plate for Gas Type, Gas Rates, Injector Sizes and Burner Pressures.**

DIMENSIONS

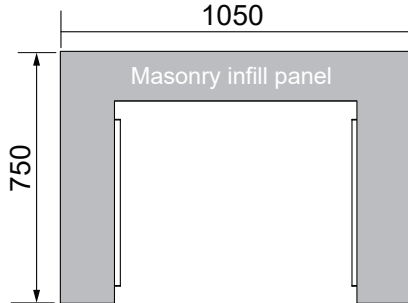
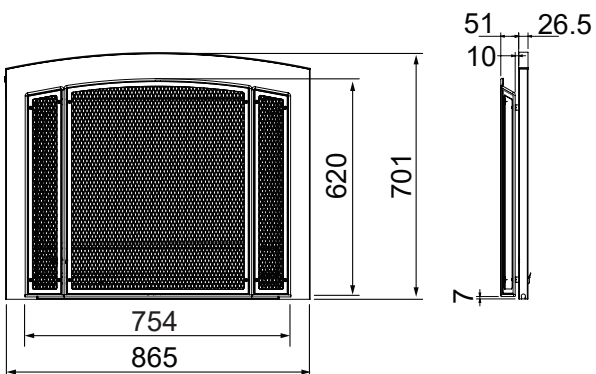
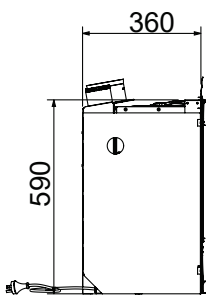
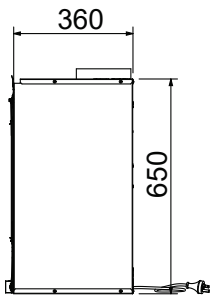
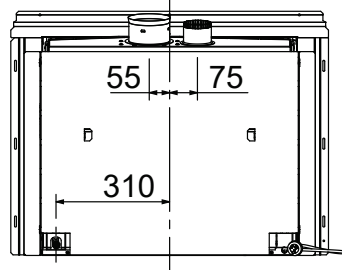
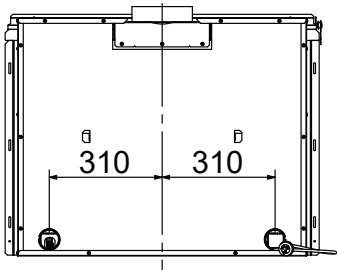
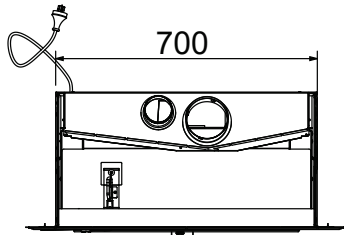
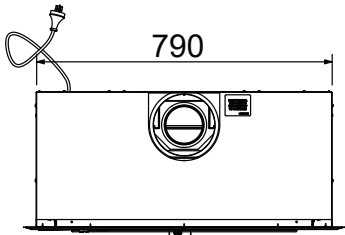
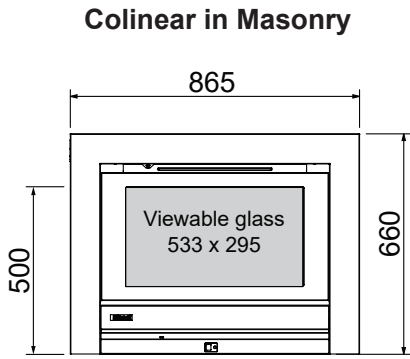
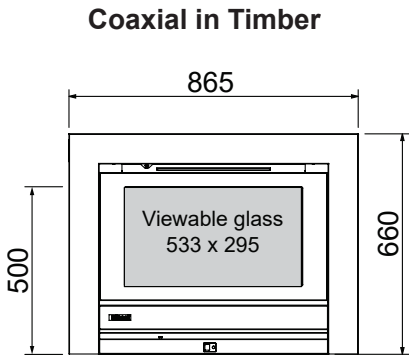

# SPECIFICATIONS

## WIRING DIAGRAM

Fire Model	Fan Type	Burner	Comb. Fan	LED	SW Model
NEO	RINNAI JAPAN	1	*	*	3
NOVO	RINNAI JAPAN	1	*	*	3

Mark	Part
B	Burner
ER	Electrode
F	Fuse Electrical
FM	Convection Fan Motor
FR1-2	Flame Rod 1-2
L	Light
OH.TH1	Over Heat Thermistor
PB	Pilot Burner
POV	Modulated Solenoid Valve
R.TH	Room Thermistor
RCR	Remote Control Circuit
SP	Sparker
SV1-3	Main Solenoid Valve 1-3
TF	Thermal Fuse
TR	Transformer

Mark	Colour
bk	black
bl	blue
gr/y	yellow-Green stripe
gy	grey
or	orange
pl	purple
r	red
w	white
y	yellow
p	pink
br	brown

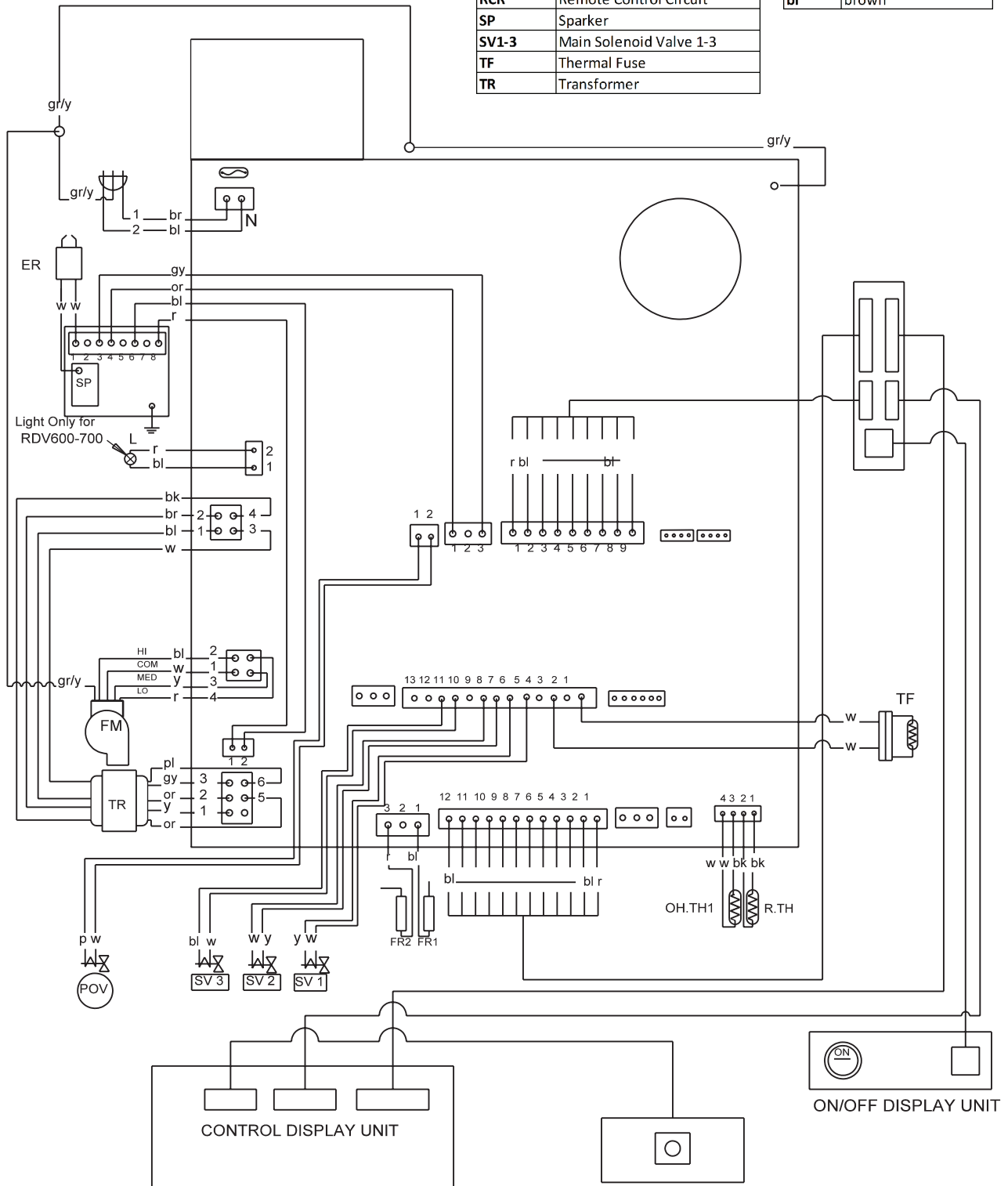







# Rinnai Australia Pty Ltd

ABN 74 005 138 769 | AU45204

82-88 Mills Road, Braeside, Victoria, 3195  
P.O. Box 460, Braeside, Victoria 3195  
Tel: (03) 9271 6625

## **Customer Support**

Tel: 1300 555 545\*

*Monday to Friday, 8.00 am to 5.00 pm EST.*

*\*Cost of a local call may be higher from mobile phones.  
(National calls from public phones in Australia are free.)*

For further information visit **[www.rinnai.com.au](http://www.rinnai.com.au)**  
or email **[enquiry@rinnai.com.au](mailto:enquiry@rinnai.com.au)**

Rinnai has a Service and Spare Parts network with personnel who are fully trained and equipped to give the best service on your Rinnai appliance. If your appliance requires service, please call our National Help Line. Rinnai recommends that this appliance is serviced every 2 years.

With our policy of continuous improvement, we reserve the right to change, or discontinue at any time, specifications or designs without notice.