

MODELS

FEPH10B

FEPH15B

FEPH22B

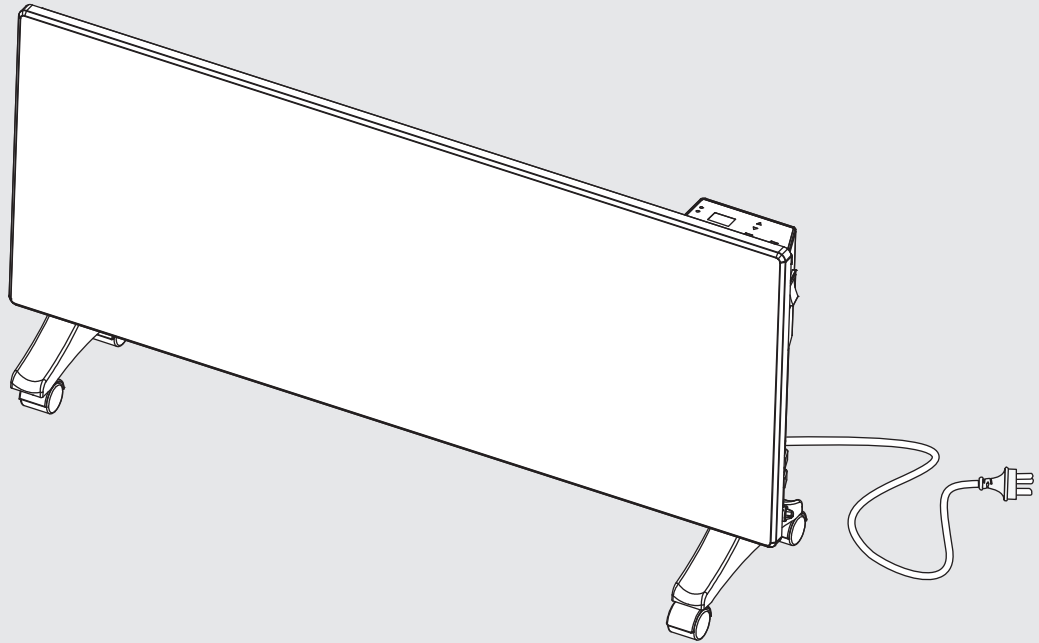

Electric Panel Heater
Operation & Installation Manual

Rinnai

Congratulations on the purchase of this Electric Panel Heater. We trust you will have many years of comfort and enjoyment from your appliance.

This appliance must be installed in accordance with:

- Manufacturer's Installation Instructions
- Current AS/NZS 3000
- Local regulations, including local OH&S requirements, and Municipal Building Codes, including the National Construction Code (NCC).

For continued safety of this appliance it must be installed and maintained in accordance with the manufacturer's instructions.

Before proceeding with the operation or installation of your new heater, please read this manual thoroughly and gain a full understanding of the requirements, features and operation of your new appliance.



TABLE OF CONTENTS

Warnings and Important Information	4
About Your Electric Panel Heater	7
Unpacking The Appliance	7
What's In The Box	7
Features	7
Specifications	7
How To Operate Your Heater / General Design Layout	8
Connecting The Power	9
Operation	9
Power Rate Mode	10
Delay Off Timer Operation	11
Anti-Frost Protection Function	12
Electronic Lock Function	12
Tilt Switch	12
Care & Maintenance	13
Care Of The Heater	13
Error Codes	13
Service And Repair	13
Disposal	13
Installation	14
General	14
Wall Installation	14
Freestanding Installation	15
Contacts	24

WARNINGS AND IMPORTANT INFORMATION



READ ALL INSTRUCTIONS BEFORE USING THE APPLIANCE.

Always comply with the following precautions to avoid dangerous situations and to ensure optimum performance.

Failure to carefully read and follow all instructions in this manual can result in equipment malfunction, property damage, personal injury and/or death.

DANGER: Indicates an imminently hazardous situation which, if not avoided, will result in personal injury or death.

WARNINGS: Indicates a potentially hazardous situation which, if not avoided, could result in personal injury or death.

CAUTIONS: Indicates a potentially hazardous situation which, if not avoided, could result in minor or moderate injury or damage to the appliance. It may also be used to alert against unsafe practices.



REGULATORY / INSTALLATION

This appliance shall be installed in accordance with:

- Manufacturer's Installation Instructions.
- Current AS/NZ 3000.

It is important that the following precautions are followed to minimise the risk of overheating, fire, electric shock and injury:

Handle the appliance with care, avoid vibrations and knocks. Unpack the appliance and check for damage. **DO NOT INSTALL A DAMAGED APPLIANCE.** If the appliance is damaged or defective, contact your supplier for advice, the appliance may **ONLY** be serviced by the manufacturer or the manufacturer's agent or similarly qualified person.

The flexible cord and plug **MUST NOT** be modified. If the power cord or its plug is damaged, it **MUST** be replaced with a new certified cord and plug installed by a suitably qualified and licensed person.

Ensure that the voltage and frequency of the power supply correspond to the ratings on the data plate of the appliance.

The heater is fitted with an Australian flexible cord and 3 pin plug intended for connection to an Australian 10 Amp socket outlet. It is not suitable for connection in other countries or alternative power supplies. Ensure that the voltage and frequency of the power supply correspond to the ratings on the dataplate of the appliance.

DO NOT use power boards or double adaptors for this appliance.

This heater **MUST** not be located immediately directly in front of a socket-outlet.

DO NOT connect the appliance to the mains power until it has been installed in its final location and adjusted to the position it will be used in.

The installation **MUST** be equipped with an all-pole disconnection mechanism in accordance with wiring rules.

If used as a portable heater, **DO NOT** use in the immediate surroundings of a bath, a shower or a swimming pool.

If used as a portable heater, unplug and allow to cool before placing in storage.

If used as a portable heater, **DO NOT** move whilst it is turned on.

DO NOT handle any parts of the heater, including the plug and flexible cord, with wet or damp hands.

DO NOT immerse the appliance, flexible cord and plug in water or any other liquid.

DO NOT place containers of any liquid or wax on top of the heater.



Turn off the appliance and unplug from the power socket outlet when not in use.

This appliance is suitable for indoor use only.

Never dismantle the appliance. Tampering with electrical connections and components is highly dangerous and may cause appliance malfunction.

The flexible cord and plug **MUST** not be modified. If the cord or plug are damaged, they **MUST** be replaced by Rinnai or a Rinnai appointed service agent.

The electrical cord **MUST NOT** come into contact with the heated parts of the appliance. **DO NOT** unplug the appliance by pulling on the flexible cord.

DO NOT coil or bundle the electric cord to reduce its length as overheating of the cord may occur which could result in a fire hazard.

This appliance **MUST NOT** be installed where curtains or other combustible materials could come into contact or in close proximity with it. In some cases curtains may need restraining.

DO NOT place articles or on or against this appliance any parts of this heater, to avoid overheating.

DO NOT sit on this heater.

DO NOT place any items of clothing, hand towels or similar over the appliance to dry.

DO NOT spray aerosols in the vicinity of this appliance whilst the appliance is operating. Most aerosols contain flammable gas, which can be a fire hazard if used near the appliance when it is in use.

DO NOT use or store flammable materials, liquids, etc. near this appliance. Combustible materials **MUST** not be placed where the appliance could ignite them.

DO NOT use the appliance in areas where the presence of flammable dust particulates may cause an explosion.

DO NOT use the appliance, in a green house, barn or stable or on a on a building site or where flammable dust may be present.

DO NOT use this appliance in the place of animal propagating areas.

DO NOT use the appliance as a sauna heater.

DO NOT leave the appliance unattended whilst in operation.

CAUTION when being operated the surfaces of this appliance will get **VERY HOT - DO NOT TOUCH ANY PART OF THE APPLIANCE WHILE IT IS TURNED ON.** To avoid burns, **DO NOT** touch the any surface of the appliance with any body part. The appliance **MUST** be located in a position that prevents contact by any person (including accidental).

The appliance will retain significant heat for a period after shut down. To avoid burns, **DO NOT** touch the any surface of the appliance with any body part during this period.

This appliance is not intended for use by persons (including children) with reduced physical, sensory or mental capabilities or lack of experience and knowledge, unless they have been given supervision or instruction concerning use of the appliance by a person responsible for their safety and have the capacity to follow those instructions.

The appliance is not intended for use by young children or infirm persons without supervision.

Young children should be supervised when in the vicinity of this appliance while it is in operation to ensure they **DO NOT** play with the appliance.

DO NOT allow children or persons with reduced physical, sensory or mental capabilities to sleep directly in front of the heater.

DO NOT allow children to 'post articles' into the louvres of the heater.

NO USER SERVICEABLE PARTS - NEVER dismantle the appliance. Tampering with electrical connections and components is highly dangerous and can result in equipment malfunction, property damage, personal injury and/or death.



DO NOT modify this appliance. Modifying from original specifications may create a dangerous situation and will void your warranty.

DO NOT use this heater if it has been dropped.

DO NOT use if there are visible signs of damage to the heater.

Use this heater on a horizontal and stable surface, or fix it to the wall, as applicable.

DO NOT use this heater in small rooms when they are occupied by persons not capable of leaving the room on their own, unless constant supervision is provided.

To reduce the risk of fire, keep textiles, curtains, or any other flammable material a minimum distance of 1 m from the air outlet.



MANDATORY INSPECTION PRIOR TO INSTALLATION

Immediately report any damage or discrepancies to your appliance supplier. This appliance has been inspected and tested at the time of manufacture and packaging, and was released for transportation without known damage. Upon receipt, inspect the exterior for evidence of rough handling in shipment. Ensure that the appliance is labelled correctly for the gas and electrical supply it is intended to be connected to.

For safety and warranty purposes, appliances that may be damaged or incorrect **MUST NOT** be installed or operated under any circumstances. No responsibility will be accepted for installation or operation of damaged or incorrect appliances. Installation of damaged or incorrect appliances may also contravene local regulations.



A NOTE ON ILLUSTRATIONS

The illustrations used in this manual are for explanatory purposes only and the shape of your unit may vary slightly from that which is shown in this manual.

ABOUT YOUR ELECTRIC PANEL HEATER

UNPACKING THE APPLIANCE

If any damage is evident DO NOT INSTALL or OPERATE and contact your supplier for advice.

WHAT'S IN THE BOX

The package should contain:

- Heater fitted with flexible cord and plug.
- A plastic bag containing the wall mounting screws.
- Operating and Installation Instructions.
- Two feet.

FEATURES

This heater incorporates the following design features.

DIY Installation

This heater is suitable for Do It Yourself installation.

Silent Operation

Electric element operation eliminates fan noise.

Draft Free

Non fan operation also means no drafts.

Delay Off Timer Function

Equipped with delay off timer, see page 11 for details.

Low Maintenance

No moving parts makes for virtually maintenance free operation.

Tilt Switch

This heater is fitted with a tilt switch that automatically places the heater into standby mode if the appliance tilts more than 45°.

'Tamper Resistant' Operation

Includes a Lock function designed to prevent accidental operation and small children from altering the heater settings.

Operation

The heater uses electricity as the heating medium. It operates on the 'natural convection' principle where air from the room is drawn into the 'air inlet' louvres at the base of the appliance, is heated inside the appliance and expelled through the 'air outlet' louvres at the top of the appliance without the use of fans. A sophisticated thermostatic system keeps the room close to the selected temperature.

SPECIFICATIONS

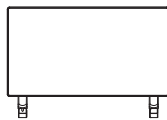
Model		FEPH10B	FEPH15B	FEPH22B	
Rated power		1000 Watt	1500 Watt	2200 Watt	
Rated voltage		240V ~ 50Hz			
Water Resistance (IP) Rating / Electrical Protection Class		IP24 / Class I			
Heater Dimensions (mm)		Height	440	440	440
		Width	615	775	1035
		Depth	125	125	125
Unit Weight (kg)		5.0	6.3	8.2	
Installation options		Wall or Freestanding			

HOW TO OPERATE YOUR HEATER / GENERAL DESIGN LAYOUT

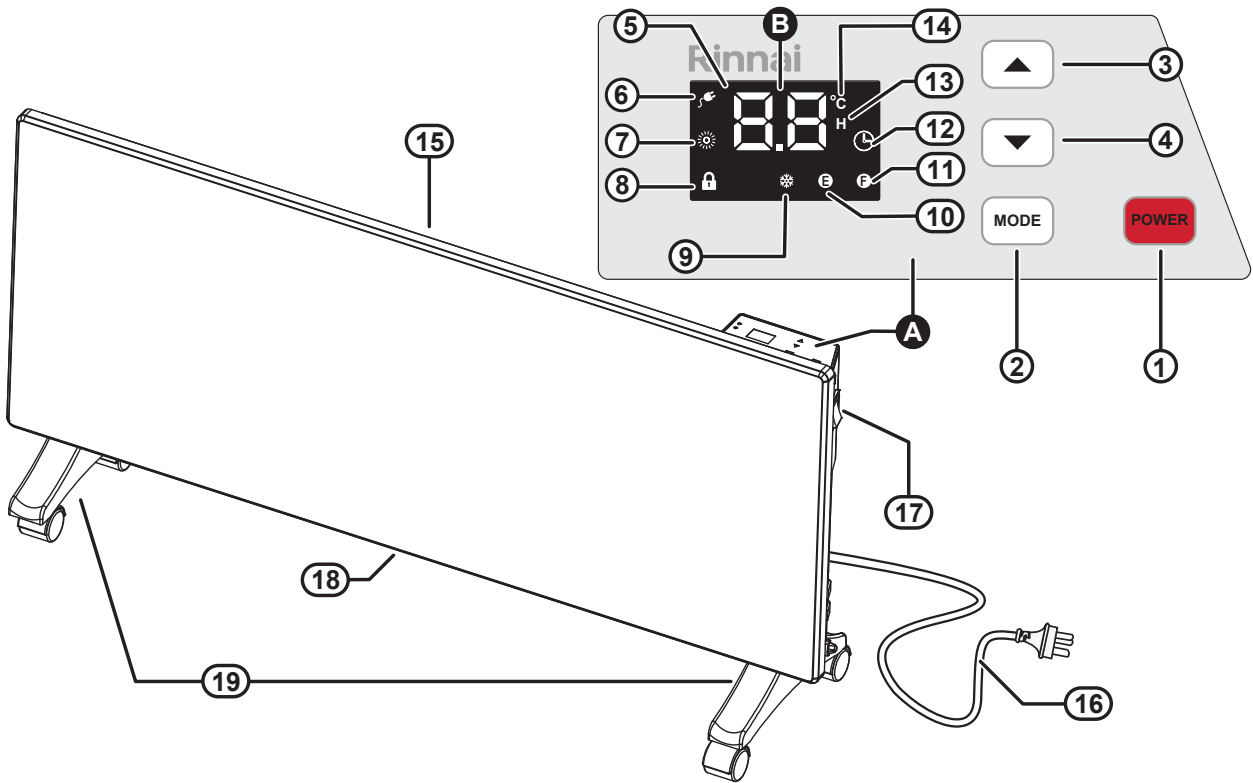

A	Control panel console
B	Digital LED display
①	POWER 'ON' / 'OFF' button
②	MODE button, Temperature/Power Rate/Timer setting
③	'UP' button
④	'DOWN' button
⑤	Temperature / Timer display
⑥	Power indicator
⑦	Heater Operation indicator
⑧	Lock indicator
⑨	Constant Frost Protection indicator
⑩	Eco mode indicator
⑪	Full mode indicator
⑫	Delay Off Timer Set indicator
⑬	Time indicator (illuminates when digital the display is showing delay timer related settings)
⑭	Degrees Celsius indicator (illuminates when the digital display is showing temperature related settings)
⑮	Vent, warm air discharge
⑯	240 Volt power cord & plug
⑰	Main Power Switch
⑱	Air inlets
⑲	Optional feet for floor mounting (see "Installation" on page 14 for installation options)



This heater features audible chimes. On start up a set of rising chimes will sound, while on shut down a set of falling chimes will sound, there is a beep for each button press.



In standby mode, press and the 'Up' 3 button until 'OF' is displayed to deactivate audible chimes. Repeat the previous step to active audible chimes.

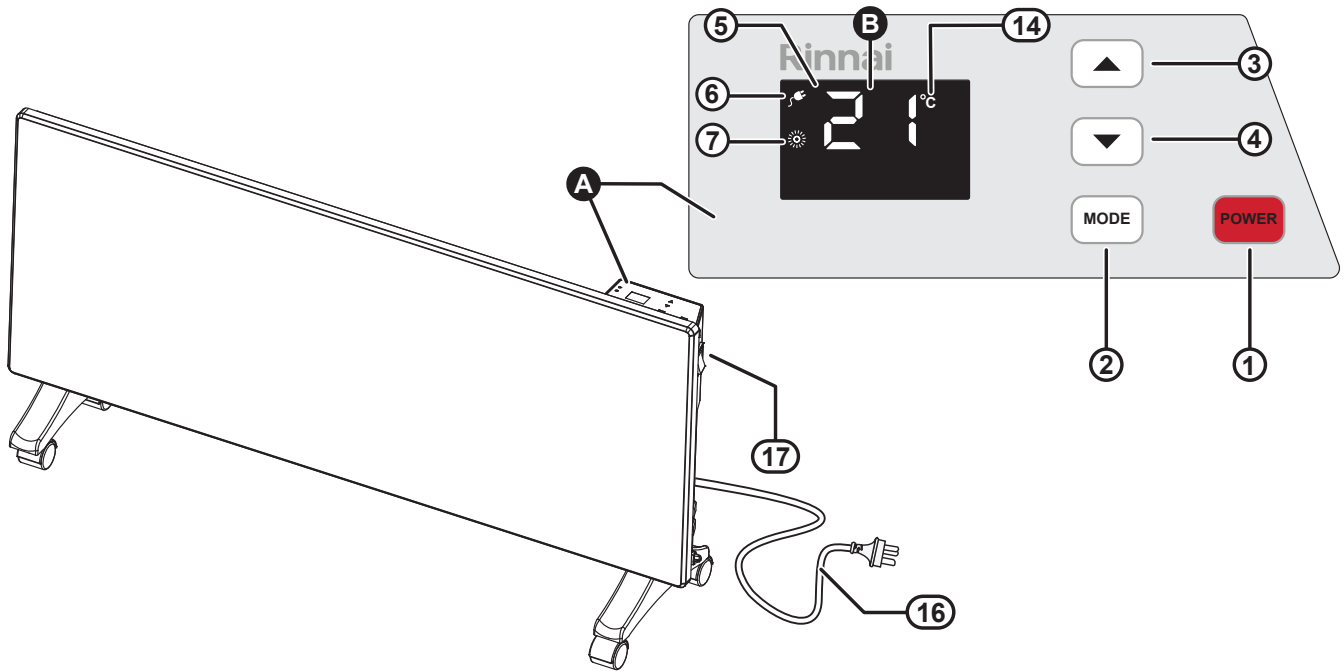

CONNECTING THE POWER

Plug the heater into a power outlet and turn the power outlet on. Turn on the main power switch (17) located on the right hand side of the appliance, to the 'on' position. The digital LED Display (B) will illuminate briefly with audible chime. The power indicator (6) will keep flashing on the digital LED Display (B) to show the heater is now in standby mode.

OPERATION

- Press the POWER button (1) on the control panel console (A) once to start heating operation, a second rising chime will sound. The two digits (5) on the display panel will now show the programmed temperature setting. The factory temperature setting for the heater is 21°C. If this is above that of the current room temperature the operation indicator (7) will illuminate and the heater will begin to heat the room.
- To change the temperature setting press the MODE button (2) once. The °C (temperature) indicator (14) on the display panel will flash.



If after 5 seconds no buttons are pressed the °C indicator will stop flashing and the display will revert back to the current operating setting. Simply press the MODE button to re-enter temperature setting operation.

Press the 'Up' (3) or 'Down' (4) buttons to increase or decrease the temperature setting. The available temperature setting range is from 5°C to 30°C.

- To exit the temperature setting operation either press the MODE button (2) three times or wait 5 seconds. The selected temperature will now be set and displayed.

If the selected temperature is above that of the current room temperature the operation indicator (7) will illuminate and the heater will begin to heat the room.

If the selected temperature is less than that of the current room temperature the operation indicator (7) will go out and the heater will go into a standby state until the room temperature has fallen below the set temperature, when the heater will then automatically switch on and heat the room.



During the operation of any soft-touch button, the display of LCD reaches maximum brightness. When there is no operation after 30 seconds the Digital LED display will dim while the power indicator (6) and the operation indicator (7) will keep minimum brightness.

- To stop heater operation completely press POWER button (1), the shutdown falling chime will sound, the power indicator (6) will remain illuminated to show that the heater has returned to standby mode.



During the initial burning in period or after long periods of non use some light grey smoke or smell may be experienced. This is normal and is caused by dust that may have settled on the heating element. During this period the space being heated should be well ventilated.

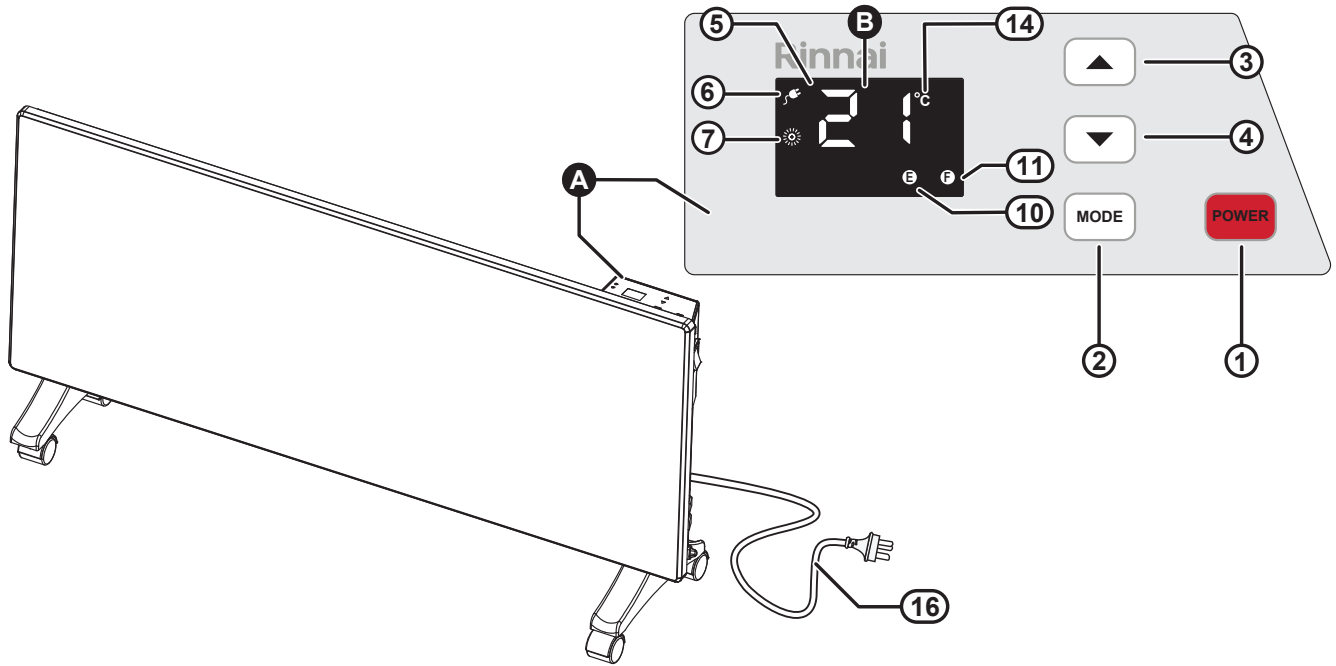

POWER RATE MODE

This allows the user to program the heater to operate Eco mode (10) (half rated power) or Full mode (11) (full rate power).

1. Press the POWER button (1) on the control panel console (A) once to start heating operation, a second rising chime will sound. The two digits (5) on the display panel will now show the programmed temperature setting.
2. To change the power rate press the MODE button (2) twice. The Eco / Full mode indicator (s) (10 / 11) on the display panel will flash. Press the 'Up' (3) or 'Down' (4) buttons to set the required mode.
3. To exit the mode setting operation either press the MODE button (2) twice or wait 5 seconds. The selected mode will now be set and displayed.

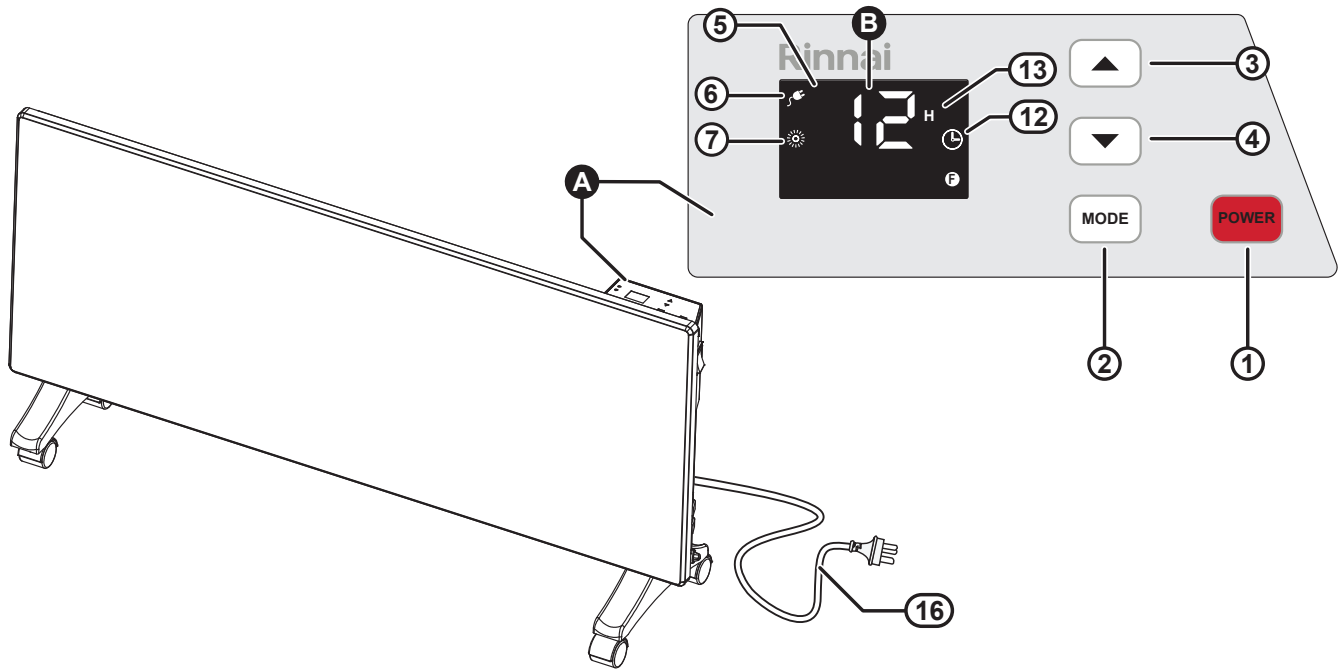

DELAY OFF TIMER OPERATION

In addition to temperature controlled operation the heater can also be operated via the use of a delay off timer. This allows the user to program the heater to operate for a set time period, after which the heater will be returned back to standby mode.

1. Set the desired operating temperature as per steps 1 through 3 “CONNECTING THE POWER” on page 9.
2. After setting the desired temperature press the MODE button ② twice. The two digits ⑤ on the display panel will now display 00 and both the Delay Off Set indicator ⑫ and the H (time) indicator ⑬ will begin to flash.



If after 5 seconds no buttons are pressed the 00 display will revert back to the current operating setting. Simply press the MODE button ② three times to re-enter the timer setting operation.

3. Press the ‘Up’ ③ or ‘Down’ ④ buttons to set the required timer operation period.
The delay off timer can be set in 1 hour increments to a maximum of 24 hours.
4. To exit the delay off timer setting operation either press the MODE button ② once or wait 5 seconds.
The two digits ⑤ on the display panel will alternate every 5 seconds between displaying the set temperature and the time remaining of the set delayed off timer period.
If the selected temperature is above that of the current room temperature the operation indicator ⑦ will illuminate and the heater will begin to heat the room.
If the selected temperature is less than that of the current room temperature the operation indicator ⑦ will go out and the heater will go into a standby state until the room temperature has fallen below the set temperature, when the heater will then automatically switch on and heat the room.
5. To cancel delay off timer and return manual operation press ‘Up’ button ③ for 5 seconds.
6. To stop heater operation completely press POWER button ①, a shutdown falling chime will be heard and the power indicator ⑥ will keep flashing to show that the heater has returned to standby mode.

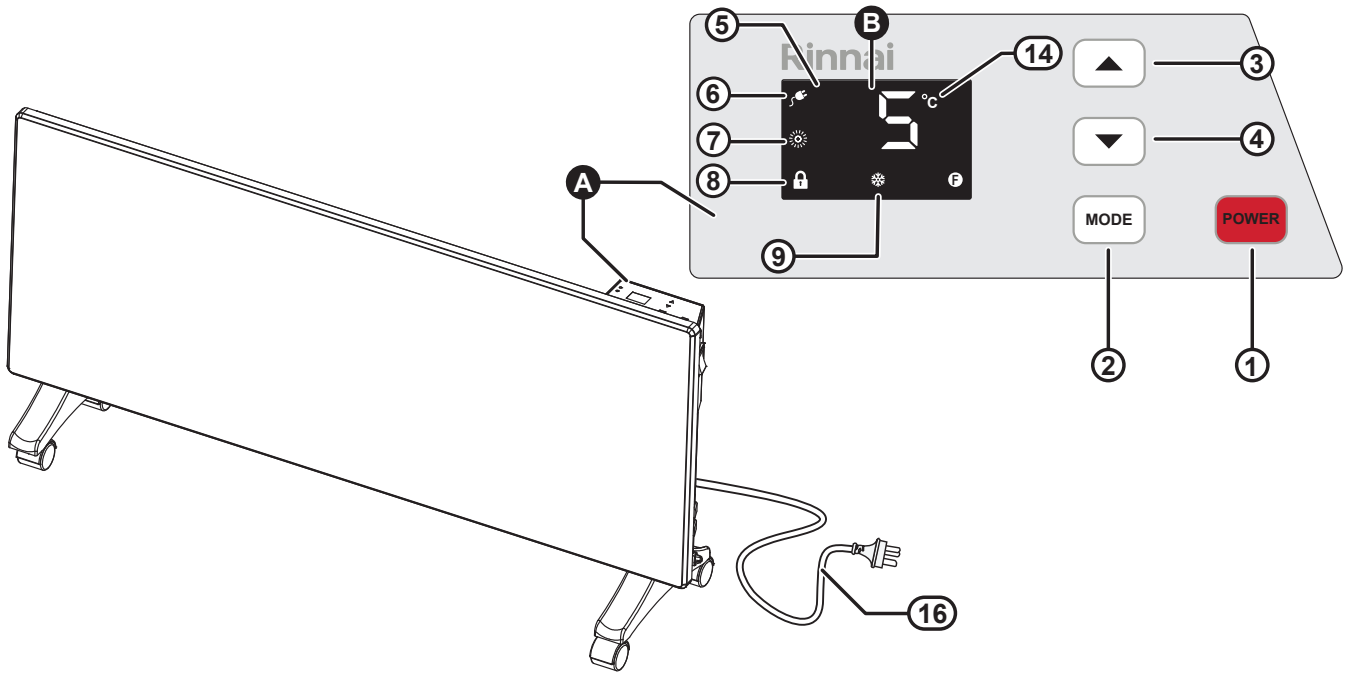

ANTI-FROST PROTECTION FUNCTION

If the set temperature ⑤ is set to 5 °C then the constant frost protection program will be activated and the constant frost protection (snowflake symbol) indicator ⑨ will be illuminated.

This is useful during winter in alpine areas where the ambient temperature is likely to fall below 5° C.

ELECTRONIC LOCK FUNCTION

The Lock function is designed to prevent accidental operation and small children from altering the heater settings.

To Activate the Lock

Press the ‘Down’ ④ button until the padlock symbol ⑧ is displayed. All control functions are now locked and none of the buttons on the control will work.

To Deactivate the Lock

To deactivate the lock, repeat locking step above to return to normal operation.



The Lock function is also deactivated if the heater is switched ‘off’ via the mains power.

TILT SWITCH

As a safety feature this heater is fitted with a tilt switch that automatically places the heater into standby mode if the appliance tilts more than 45°.

When the heater is returned to an upright position, normal operation will then be resumed.

CARE OF THE HEATER

Due to the 'natural convection' operating principle it is normal that some dust and fluff may build up at the air inlet and air outlet louvres over time. This will reduce operating effectiveness and may result in the appliance overheating if left for too long.

DO NOT use solvents to clean any parts.

To remove dust and clean the appliance:

1. Unplug the electric plug of the heater from the socket outlet before commencing cleaning.
2. Allow to cool down.
3. Use a vacuum cleaner to remove any dust and fluff from the inlet and outlet louvres.
4. All parts of the heater can be cleaned using a soft, damp cloth with some mild detergent (such as dishwashing liquid) if required.
5. Ensure the heater is dry before reconnecting to the electricity supply.

ERROR CODES

Your Rinnai panel heater has a self diagnostic capability. If a fault occurs, an Error Code will flash on the two digits ⑤ of Digital LED display ⑥, a repeating chime will also sound and the appliance will be prevented from operating.

Please quote the error code displayed when enquiring about service.

Error Code E 0 - Temperature sensor disconnection.

SERVICE AND REPAIR

The flexible cord and plug must not be modified. If the power cord or its plug is damaged, it must be replaced with a new certified cord and plug installed by a suitably qualified and licensed person.

There are no user serviceable parts inside the appliance. If an appliance is faulty and under warranty, you can return it to the place of purchase for a refund or replacement. If the appliance is faulty and out of warranty, you must dispose of it correctly, following the disposal procedure as detailed below.

DISPOSAL

Electrical appliances may contain materials which, if handled or disposed off incorrectly, present a hazard to humans or the environment.

DO NOT dispose of your old appliance with your household waste. Dispose of your old appliance at your local community waste collection / recycling centre and ensure it presents no danger to children whilst being stored for disposal.

INSTALLATION

GENERAL

This heater is suitable for Do It Yourself installation. It can be either wall mounted (fixed installation) or freestanding by mounting castors in accordance with these instructions. A Phillips head screwdriver is included for freestanding installation. For wall installation other tools and hardware may be required, depending on the wall material.

WALL INSTALLATION

The clearance from the sides and front of the heater **MUST BE** at least 100mm and the clearance above the heater **MUST BE** 300mm as shown in the diagram below.

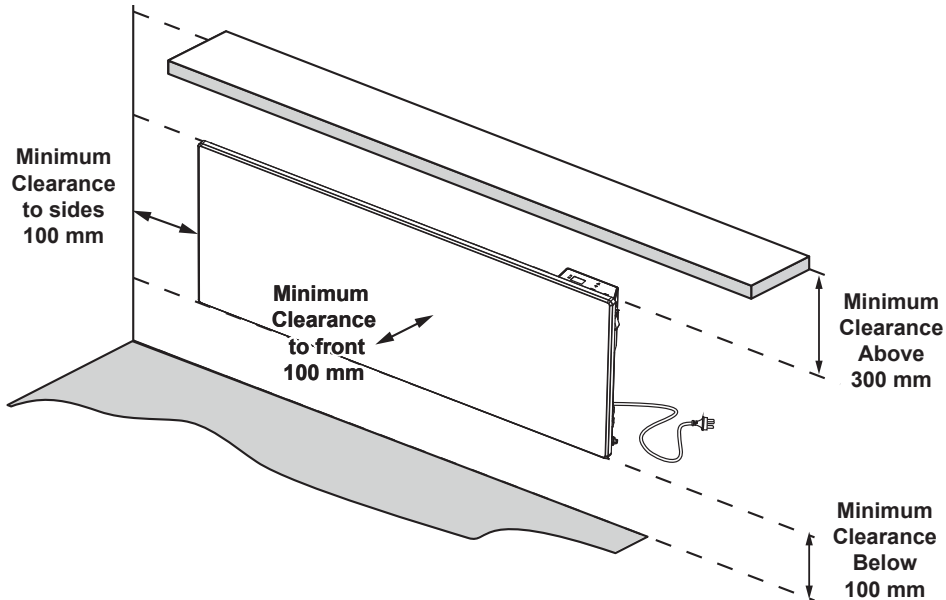

- This heater **MUST NOT** be located immediately below a socket-outlet.
- This heater **MUST** be positioned within one metre of a socket-outlet to ensure the flexible cord and plug can reach it.
- This heater is **NOT** designed to be built in.
- **DO NOT** attach the castors to the heater base for wall installations.
- The heater is suitable for installation in non-communal baths and shower areas or bathrooms. It is to be installed such that switches and other controls cannot be touched by a person in the bath or shower. Consult your licensed electrical trades person for installation in communal baths and shower areas or bathrooms.

1. Ensure the heater is unplugged from the power socket outlet and the 'on / off' switch is in the off position before commencing wall mounting.

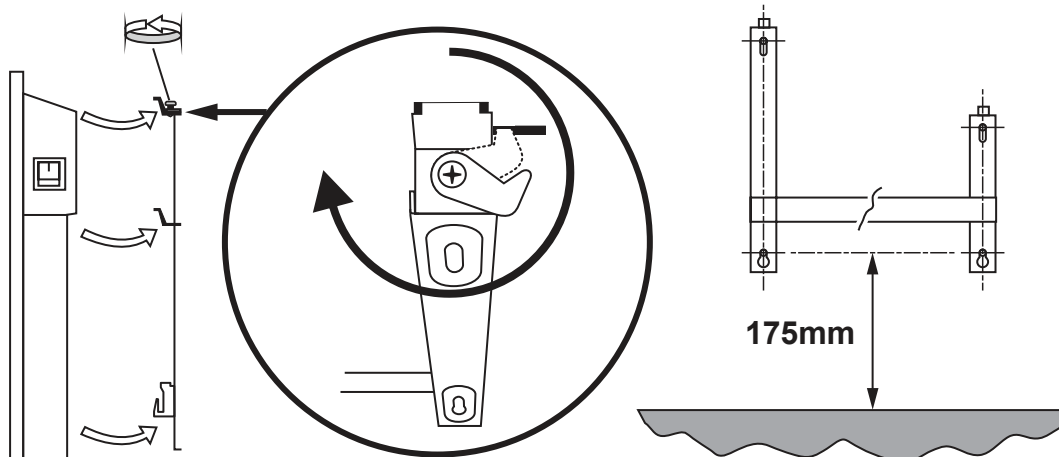

2. Loosen the locking latch on the taller leg of the mounting bracket and detach the mounting bracket from the back of the panel heater.

3. Position the mounting bracket on the wall. Ensure the two bottom mount holes are at least 175mm from the floor and drill holes as required. Secure the mounting bracket to the wall with the 4 mounting screws.
4. Secure the mounting bracket to the wall with the 4 mounting screws. For masonry walls use the plastic plugs with screws provided. For plaster walls obtain suitable plasterboard fasteners from a building hardware supplier.

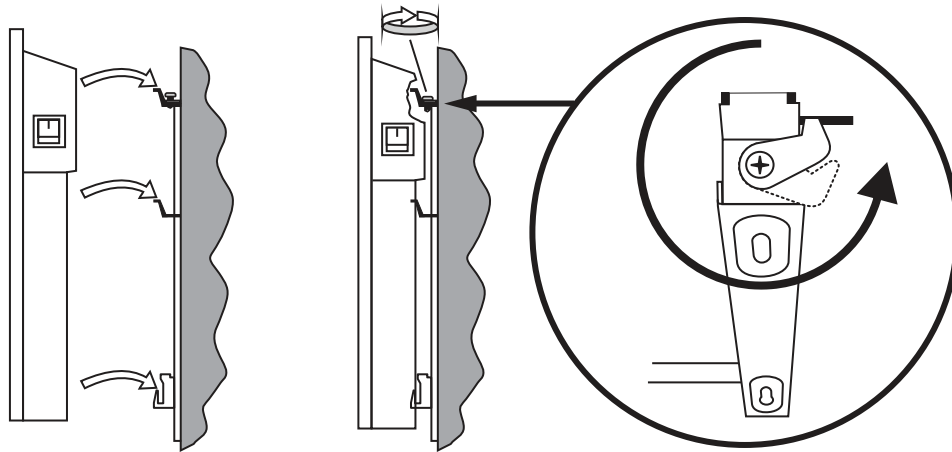

5. Re-attach heater to the mounting bracket (reverse method of step 2) and secure with the locking screw(s).
6. Remove the cable tie from the flexible cord and insert the 2 pin plug of the heater into the power socket outlet. **DO NOT** bundle or coil the flexible cord to reduce it's length as overheating and subsequent fire hazard could result.

FREESTANDING INSTALLATION

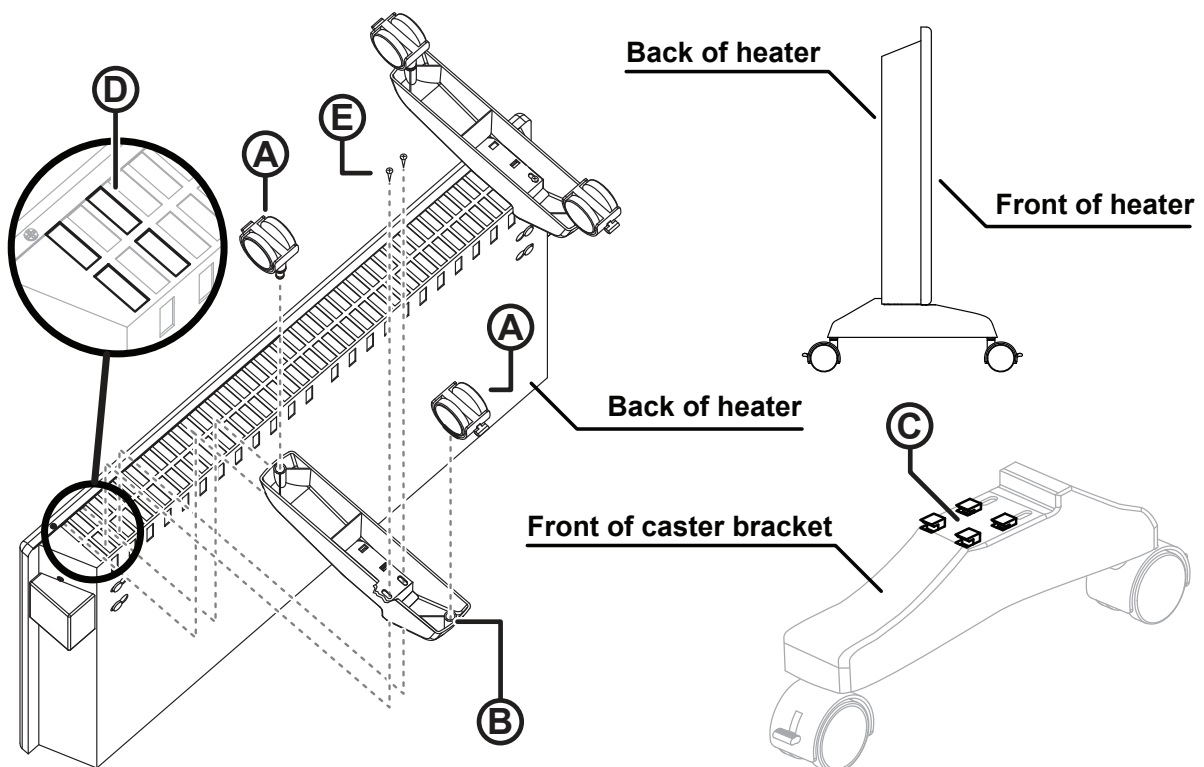

1. Be sure heater is unplugged and power switches are off.
2. Place the heater in an 'upside down' position with the back of the heater facing you.
3. Assemble the 2 castors **A** to the each castor bracket **B** by pushing the metal shaft fully home.

INSTALLATION

4. With the front end of the castor support bracket pointed towards the front of the heater, align the four locating tabs **Ⓒ** with the four of the outer most air inlets **Ⓓ** then push down and forward until the tabs are fully engaged with the heater. Then secure each of the castor brackets in place with retaining screws **Ⓔ**, using two for each.
5. Remove the cable tie from the flexible cord and insert the 3 pin plug of the heater into the power socket outlet. **DO NOT** bundle or coil the flexible cord to reduce it's length as overheating and subsequent fire hazard could result.

TERMS OF WARRANTY – AUSTRALIA

Rinnai Australia Pty. Ltd. ABN 74 005 138 769, 82-88 Mills Road, Braeside, Victoria, 3195.

1 DEFINITIONS

The terms listed below shall have the following meanings:

- 1 **“Authorised Service Representative”** means an independent service contractor authorised by Rinnai or Rinnai service personnel.
- 2 **“Rinnai”** means Rinnai Australia Pty Ltd (ABN 74 005 138 769) and any related company.
- 3 **“Certificate(s) of Compliance”** means certificate(s) issued by licensed personnel (including plumbers, refrigeration mechanics, electricians or other relevant tradespeople) to certify that any prescribed works comply with applicable regulatory requirements.
- 4 **“Certificate(s) of Occupancy”** means certificate(s) issued by the local government authority (or similar organisation) which certifies that a home can be occupied.
- 5 **“Installation Site”** means the site at which the Product is originally installed.
- 6 **“Normal Business Hours”** means 8:30am to 5:00pm Monday to Friday, excluding public holidays.
- 7 **“Operating/Installation Instructions”** means the user manual or other documentation which provides detailed instructions on the proper operation and maintenance of the Product.
- 8 **“Other Applications”** means any Product used for purposes other than Residential & Light Commercial Applications. Other Applications may include but are not limited to factory, IT/Server room, telephone exchange, processing area (e.g. bakery, kitchen, warehouse, swimming pool, agricultural facilities such as a nursery). Any Product which has been installed, for whatever purpose, as a retrofit component to an existing system, will also be classed as being part of an “Other Application” regardless of the purpose of use of the existing system into which such product has been installed.
- 9 **“Purchaser”** means the end user of the Product, the person named as owner in the Warranty certificate, the holder of the Proof of Purchase or the holder of a property transfer document where the Product is included as part of the chattels.
- 10 **“Product”** means the equipment purchased by the Purchaser and described in Section 2 of this document.
- 11 **“Proof of Purchase”** means a Tax Invoice or Receipt in respect of the Product. In the case of new constructions, a Certificate of Occupancy or a Certificate of Compliance that details the date of installation or commissioning will suffice.
- 12 **“Qualified Installer”** means the qualified installation contractor who is responsible for performing the installation work in the manner prescribed by local and statutory regulations, including compliance with any relevant and to Rinnai specifications, including Australian Standards.
- 13 **“Residential & Light Commercial Applications”** means any Product for use in residential or light commercial applications where
 - a) the Product is solely used for the purpose of human comfort; and
 - b) the ambient temperature of the space the Product is intended to heat or cool is influenced solely or primarily by natural exterior weather conditions rather than by man-made or mechanical heat sources.

Examples of Residential & Light Commercial Applications include, homes, offices, hotels, apartments, nursing homes, hospitals, health care premises, shopping centres, and retail stores.

2 TERMS OF WARRANTY

2.1 Subject to the terms of warranty set out in this document, and effective from the date of completion of installation, the product is warranted to be free from defects in materials & factory workmanship for the period set out in the table below:

	PRODUCT GROUPS	PARTS	LABOUR
Residential and Light Commercial	Evaporative Coolers & Ducted Gas Heaters (excluding CC3 Compact Classic Series)	5 Years *Extended 4 Years Option	5 Years *Extended 4 Years Option
	Ducted Gas Heaters - CC3 Compact Classic Series	3 Years	3 Years
	Refrigerated Air Conditioning Products	7 Years	7 Years
	Add-On ICE Refrigerated Cooling System	5 Years	5 Years
	VRF Air Conditioning Products	5 Years	5 Years
	Ducted Gas Heaters - Heat Exchangers and Burners Evaporative Coolers - Structural components only	10 Years	N/A
	Portable Air Conditioning ⁽¹⁾ / Dehumidifier ⁽¹⁾ / Air Purifier ⁽¹⁾	2 Years	N/A
	Electric Panel Heaters ⁽¹⁾	7 Years	N/A
	Electric Fire Heater	5 Years	5 Years
	Outdoor Radiant Heater	3 Years	1 Year
	Wi-Fi Devices	1 Year	1 Year
Commercial	Refrigerated Air Conditioning Products	2 Years	1 Year
Other Applications	All Product Groups	2 Years	1 Year
After Market	Spare Parts	1 Year	N/A
*Extended Warranty Option	Up to 4 year extended warranty (in addition to the standard warranty period listed above) applies on selected products when you opt in to the Rinnai Service Advantage program. This program has terms and conditions, including the requirement for scheduled servicing of the product by Rinnai. To participate in the program you must register your product online at: www.rinnai.com.au/support-resources/warranty-registration/ within the first 12 months of the product being installed.		

⁽¹⁾ To make a claim under this warranty, please contact your place of purchase within the warranty period.

- 2.2 Rinnai will determine in its sole discretion, which classification the Product fits into and the corresponding Warranty that shall apply.
- 2.3 An Authorised Service Representative will repair or replace, at its option, the Product or any part of the Product that its examination shows to be defective. The repair or replacement shall be performed during Normal Business Hours by an Authorised Service Representative. Repair by persons other than an Authorised Service Representatives may void the Warranty.
- 2.4 Alternatively to clause 2.3 above, Rinnai can at its discretion elect to pay you an amount equivalent to the cost of repairing or replacing the Product.
- 2.5 If Rinnai provides you with either the replacement costs or replacement product, ownership of the original Product shall immediately transfer to Rinnai.
- 2.6 Rinnai is responsible for reasonable costs associated with legitimate warranty claims, including call-out of an Authorised Service Representative to inspect the Product. Rinnai is not responsible for:
 - a) costs for tradespeople engaged by you that are not Rinnai Authorised Service Representatives.
 - b) any costs, including call out costs for a Rinnai Authorised Service Representatives, associated with a Product which is determined upon inspection not to be covered by this warranty.
- 2.7 Rinnai will reimburse any reasonable costs associated with making a legitimate warranty claim against Rinnai which are not otherwise specified above.
- 2.8 The Warranty of the Product requires that, in addition to all other conditions, the Purchaser conducts regular and/or preventative maintenance as may be specified by the Operating/Installation Instructions or otherwise directed by Rinnai and required by the level of usage and the usage environment, including the use of correct and uncontaminated refrigerants and lubricants. Refrigeration, plumbing and electrical works must be undertaken by licensed personnel.
- 2.9 Where a Product or failed component is replaced under warranty, the time remaining on the original Product warranty period will continue to apply and the replacement product or part will be subject to the original warranty period only.

3 CONDITIONS OF WARRANTY

- 3.1 The Purchaser may only obtain the benefit of the Warranty if the Purchaser:
- maintains and has the Product serviced in accordance with the instructions set out in the service section of the relevant Service or Owner's Manual;
 - complies with clause 7 "Purchaser's Responsibilities";
 - notifies Rinnai within 30 days of a defect occurring or, in the case of a latent defect, becoming apparent, that a claim is being made under this Warranty; and
 - provides, in support of the claim made under this Warranty, a proof of date of completion of installation.
- 3.2 This document (and any statutory consumer guarantees) represents the only Warranty given by Rinnai in respect of the Product. No other person or organisation is authorised to offer any alternative warranty on behalf of Rinnai.
- 3.3 If the date of completion of installation cannot be established to Rinnai's satisfaction, the date shall be deemed to be 2 months after the date of manufacture or date of sale by Rinnai, whichever is the latter.
- 3.4 This warranty applies to Products which are manufactured on or after the date of publication of this warranty but before the next date of publication of this warranty.

4 EXCLUSIONS

- 4.1 This Warranty **DOES NOT** cover:
- damage, problems or failure resulting from improper operation and/or inadequate maintenance by the Purchaser (refer Purchaser's Responsibilities section below);
 - damage, problems or failure resulting from improper or faulty installation. The Product must be installed by a Qualified Installer in accordance with the Rinnai installation instructions and applicable regulations. Where applicable, Certificate(s) of Compliance must be obtained by the purchaser from the Qualified Installer and presented to the Authorised Service Representative;
 - damage, problems or failure caused by factors external to the Product including, but not limited to, faulty or poor external electrical wiring, incorrect or faulty power supply, voltage fluctuations, over voltage transients or electromagnetic interference, inadequate or faulty gas, drainage services, or water services, including water pressure, and non-potable water;
 - damage, problems or failure caused by acts of God, fire, wind, lightning, flood, storm, hail storm fallout, vandalism, earthquake, war, civil insurrection, misuse, abuse, negligence, accident, pests, animals, pets, vermin, insects, spiders/bugs or entry of foreign objects or matter into the Product such as dirt, debris, soot or moisture;
 - damage, problems or failure caused by environmental conditions including, but not limited to, excessive moisture, salt or other corrosive substances or atmospheric conditions;
 - Product which has been installed in a portable or mobile building, structure or application including, but not limited to, a caravan, boat or trailer;
 - Product which has been re-installed at a location other than the original site;
 - any consumable item supplied with the Product including, but not limited to, an air filter, battery, fan belt, igniter or cooler pad;
 - installation of third-party components that may be attached to the Product. These include, but are not limited to, control wiring, ducting, return air filter(s) grille, register, diffuser, zone motors, controls/thermostats, safety trays, pipe work and fabricated or added components. These items remain solely the responsibility of the Qualified Installer;
 - installations where electrics/electronics may be subjected to moisture/chemicals (e.g. swimming pools or nurseries);
 - any repair, which is needed as a result of an accident, misuse, abuse or negligence;
 - Product that is utilised in an environment (indoor and outdoor) outside its specified operating range; and
 - fair wear and tear to the Product.
 - On-site labour warranty on portable (non-fixed installation) Products – In respect of such Products the Purchaser must return the Product to the supplier for repair or replacement).

5 LIMITATIONS

- 5.1 Third parties are often involved in providing advice to consumers about the climate control solutions best suited to the consumer's needs. Any advice or recommendations given by such parties, including advice about Product fitness for purpose and overall system design, sizing and application are not the responsibility of Rinnai. This includes but is not limited to the heat load calculations, airflow and system balancing.
- 5.2 This Warranty does not apply to any Product installed at an Installation Site which is outside Australia.
- 5.3 Except where inconsistent with the purchaser's statutory rights and the rights given by this Warranty, all liabilities of Rinnai for any direct, special, indirect or consequential loss or damage, any damage or expense for personal injury or any loss or destruction of property, arising directly or indirectly from the use or inability to use the Product or any of its parts and/or servicing the Product, are expressly excluded.

6 TRAVEL, TRANSPORT & ACCESS COSTS

- 6.1 The Purchaser must pay freight charges, in-transit insurance expenses and travelling costs for repairs/replacements under this Warranty, that are required to be performed 50km from the nearest Rinnai branch or Authorised Service Representative.
- 6.2 Subject to clause 6.3, Rinnai will pay freight charges, in-transit insurance expenses and travelling costs for repairs/replacements that are required to be performed less than 50km from the nearest Rinnai branch or Authorised Service Representative, subject to the following:
- Rinnai will arrange for such repairs/replacements and make any payment directly to the third party to provide the freight, in-transit insurance or travel services; or
 - if Rinnai considers appropriate, it will authorise the Purchaser in writing to pay for the relevant freight charges, in-transit insurance expenses or travelling costs and then, upon provision by the Purchaser to Rinnai of a tax invoice showing those costs have been incurred, reimburse the Purchaser for such costs which are within the terms of the authorisation. If the Purchaser pays for the relevant freight charges, in-transit insurance expenses or travelling costs without written authorisation from Rinnai, Rinnai will not reimburse the Purchaser for such costs.
- 6.3 The Purchaser must pay all costs and expenses in respect of:
- any service call out fee if the Product is not accessible for service
 - making the Product accessible for service, for example, restricted access or working at heights, or the labour cost for an additional person due to OHS requirements.
 - providing a safe working environment for installation, service, maintenance or repair of the Product;
 - any surcharge applicable in respect of supplying replacement parts outside Normal Business Hours; and
 - any other costs and expenses in relation to claiming the Warranty that is not covered by clause 6.2.

7 PURCHASER'S RESPONSIBILITIES

- 7.1 The Purchaser must operate and maintain the Product in accordance with the Operating Instructions and service maintenance schedule, including conducting an appropriate number of services to the unit during the Warranty period, based on usage and the usage environment including but not limited to;
- regularly cleaning the air filter(s) and replacing them where necessary;
 - replacing expired batteries or other consumables as required;
 - ensuring that the condensate drain is kept clean and clear of obstructions.

HOW TO MAKE A WARRANTY CLAIM:

If you wish to make a warranty claim in respect of any Portable Product, please return it to the place of purchase, or if that is not possible, contact Rinnai to enquire about alternative arrangements.

If you wish to make a warranty claim in respect of any fixed Product, please contact Rinnai on the details set out below to make arrangements for an Authorised Service Representative to inspect the product.

As per clause 2.6 of the Terms and Conditions of Warranty, purchasers are responsible for the costs of any repair and/or call out fee where, on inspection, the alleged defect is found by Rinnai's Authorised Service Representative not to be covered by this warranty or any statutory consumer guarantee applicable to the Product.

The Terms and Conditions of Warranty contain important information about your rights and obligations under this warranty. Please read them fully and carefully before making a claim.

NOTICE TO CONSUMERS UNDER AUSTRALIAN CONSUMER LAW

Our goods come with guarantees that cannot be excluded under the Australian Consumer Law. You are entitled to a replacement or refund for a major failure and compensation for any other reasonably foreseeable loss or damage. You are also entitled to have the goods repaired or replaced if the goods fail to be of acceptable quality and the failure does not amount to a major failure.

Our services come with guarantees that cannot be excluded under the Australian Consumer Law. For a major failure with the service, you are entitled to cancel your service contract with us and obtain a refund for the unused portion, or to compensation for its reduced value. You are also entitled to be compensated for any other reasonably foreseeable loss or damage. If the failure does not amount to a major failure you are entitled to have problems with the service rectified in a reasonable time and, if this is not done, to cancel your contract and obtain a refund for the unused portion of the contract.

The benefits provided by this Warranty are in addition to any other rights and remedies available to a consumer under the Australian Consumer Law and any other law which may apply to the goods and or services.

NOTES



Rinnai Australia Pty Ltd

ABN 74 005 138 769 | AU45204

82-88 Mills Road, Braeside, Victoria, 3195
P.O. Box 460, Braeside, Victoria, 3195
Tel: (03) 9271 6625

Customer Support

Tel: 1300 555 545*

Monday to Friday, 8.00 am to 5.00 pm EST.

**Cost of a local call may be higher from a mobile phone.
(National calls from public phones in Australia are free.)*

For further information visit www.rinnai.com.au
or email enquiry@rinnai.com.au

Rinnai has a Service and Spare Parts network with personnel who are fully trained and equipped to give the best service on your Rinnai appliance. If your appliance requires service, please call Customer Support.

With our policy of continuous improvement, we reserve the right to change, or discontinue at any time, specifications or designs without notice.