

RINNAI SLIM FOUR-WAY CASSETTE MODELS

Indoor	Outdoor
CIN070R	DONSR07Z72
CIN100R	DONSR10Z72
CIN120R	DONSR12Z72
CIN140R	DONSR14Z72

This appliance shall be installed in accordance with:

- Manufacturer's Installation Instructions
 - Current AS/NZS 3000
 - Local Regulations and Municipal Building Codes including local OH&S requirements
- This appliance must be installed, maintained and removed only by an Authorised Person.
For continued safety of this appliance it must be installed and maintained in accordance with the manufacturer's instructions.



Table of Contents

Installation Manual

1	Accessories	04
2	Safety Precautions	05
3	Installation Overview	07

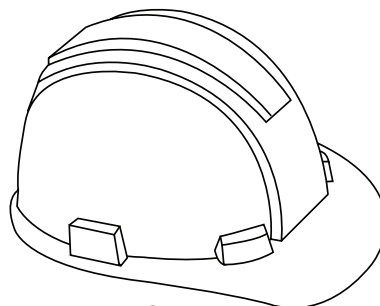

4	Indoor Unit Installation	08
	a. Indoor Unit Parts	08
	b. Indoor Unit Installation Instructions	09

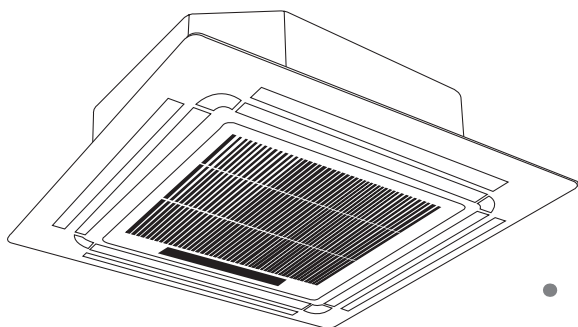

5	Outdoor Unit Installation	12
	a. Outdoor Unit Installation Instructions	12
	b. Outdoor Unit Types and Specifications	13
	c. Notes on Drilling Hole in Wall	14

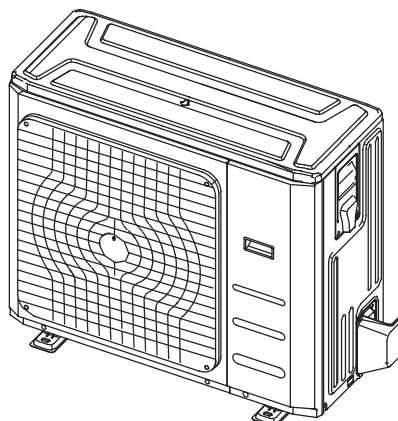

6	Drainpipe Installation	15
----------	-------------------------------------	----

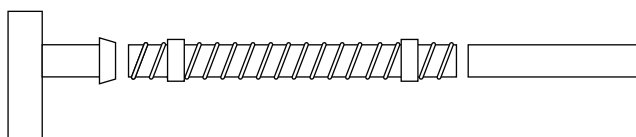

7 Refrigerant Piping Connection17

- A. Notes on Pipe Length and Elevation.....17
- B. Refrigerant Piping Connection Instructions..18

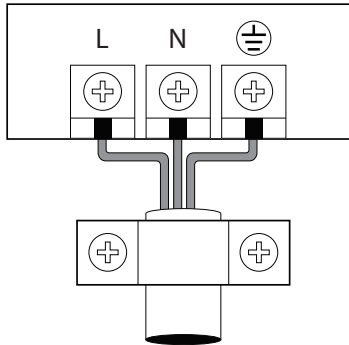
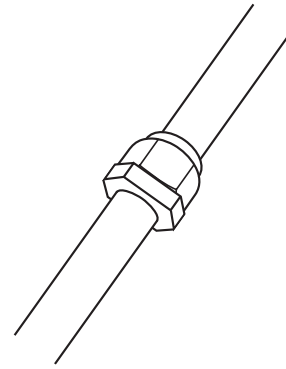

8 Wiring..... 20

- a. Outdoor Unit Wiring.....20
- b. Indoor Unit Wiring21
- c. Technical Specifications.....22
- d. Wiring Diagram22

9 Air Evacuation 23

- a. Evacuation Instructions 23
- b. Note on Adding Refrigerant..... 24

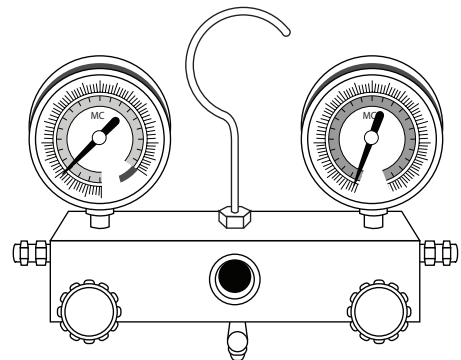

10 Panel Installation.....25

11 Test Run.....27

OPERATION RANGE LIMITATIONS











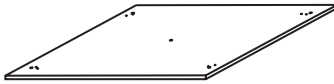

The table below indicates the temperature ranges the air conditioner can be operated within.

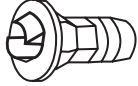
	COOL MODE	HEAT MODE	DRY MODE
Room Temperature	17°C ~ 32°C	0°C ~ 30°C	10°C ~ 32°C
Outdoor Temperature	-15°C ~ 50°C	-15°C ~ 24°C	0°C ~ 50°C

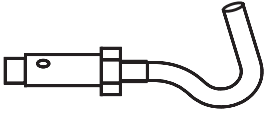
Accessories

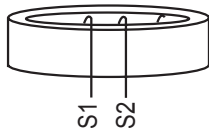
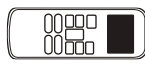
1

The air conditioning system comes with the following accessories. Use all of the installation parts and accessories to install the air conditioner. Improper installation may result in water leakage, electrical shock and fire, or cause the equipment to fail.

	Name	Shape	Quantity
Indoor unit installation	Installation paper template		1
	Refrigeration Fittings	Soundproof/insulation sheath (some models)	
Drainpipe Fittings	Outlet pipe sheath (some models)		1
	Outlet pipe clasp (some models)		1
	Drain joint (some Outdoor models)		1
	Seal ring (some Outdoor models)		1
Installation Accessory	Ceiling hook		4
	Suspension bolt		4
EMC Magnetic Ring	Magnetic ring (wrap the electric wires S1 & S2 around the magnetic ring five times.		1
Remote controller	Remote controller		1
	Fixing screw for remote controller holder ST2.9 x 10		2
	Remote controller holder		1
	Dry battery AAA		2
	Owner's manual		1
	Installation manual		1

Read Safety Precautions Before Installation

Incorrect installation due to ignoring instructions can cause serious damage or injury. The seriousness of potential damage or injuries is classified as either a WARNING or CAUTION.



WARNING

Failure to observe a warning may result in death. The appliance must be installed in accordance with national regulations.



CAUTION

Failure to observe a caution may result in injury or equipment damage.

WARNING

- Carefully read the Safety Precautions before installation.
- In certain functional environments, such as kitchens, server rooms, etc., the use of specially designed air-conditioning units is highly recommended.
- Only trained and certified technicians should install, repair and service this air conditioning unit.
Improper installation may result in electrical shock, short circuit, leaks, fire or other damage to the equipment and personal property.
- Strictly follow the installation instructions set forth in this manual.
Improper installation may result in electrical shock, short circuit, leaks, fire or other damage to the equipment.
- Before you install the unit, consider strong winds, typhoons and earthquakes that might affect your unit and locate it accordingly. Failure to do so could cause the equipment to fail.
- After installation, ensure there are no refrigerant leaks and that the unit is operating properly. Refrigerant is both toxic and flammable and poses a serious health and safety risk.



Note about Fluorinated Gasses

1. This air-conditioning unit contains fluorinated gasses. For specific information on the type of gas and the amount, please refer to the relevant label on the unit itself.
2. Installation, service, maintenance and repair of this unit must be performed by a certified technician.
3. Product uninstallation and recycling must be performed by a certified technician.
4. If the system has a leak-detection system installed, it must be checked for leaks at least every 12 months.
5. When the unit is checked for leaks, proper record-keeping of all checks is strongly recommended.

Safety Precautions

READ ALL INSTRUCTIONS BEFORE USING THE APPLIANCE

Always comply with the following precautions to avoid dangerous situations and to ensure optimum performance. Failure to carefully read and follow all instructions in this manual can result in equipment malfunction, property damage, personal injury and/or death.

-  **WARNINGS: WHEN IGNORED, CAN RESULT IN SERIOUS INJURY OR DEATH.**
-  **CAUTIONS: WHEN IGNORED, CAN RESULT IN MINOR INJURY OR PRODUCT DAMAGE.**
-  **THIS SYMBOL INDICATES THAT YOU MUST NEVER PERFORM THE ACTION INDICATED.**

REGULATORY / INSTALLATION

This appliance shall be installed in accordance with:
Manufacturer's Installation Instructions.

Current AS/NZS 3000.

Local Regulations and Municipal Building Codes including local OH&S requirements.





This appliance must be installed, maintained and removed by an Authorised Person.

For continued safety of this appliance it must be installed and maintained in accordance with the manufacturers instructions.

This appliance uses R410A refrigerant.

This appliance is heavy, use 2 people or mechanical lifting device. Improper lifting may result in serious injury.

Take care when opening or unpacking this appliance. Failure to do so may result in serious injury or product failure.



-  **DO NOT** modify the electrical wiring of this appliance. If the control power wiring is damaged or deteriorated then it must be replaced by an authorised person. Failure to do so may result in electric shock, fire, serious injury or product failure.
-  **DO NOT** install the air conditioner on an unstable or non level surface or where there may be a danger of it falling. It may result in death, serious injury, or product failure.
-  **DO NOT** install the outdoor unit where noise may cause nuisance.
-  **DO NOT** install the outdoor unit where it will be exposed to sea wind (salt spray) as this will reduce durability.

This manual applies to a 1:1 wall mounted system application.

Several indoor units covered in this manual have an "M" suffix in their Model Number. These units can also be used on selected Rinnai Multi Split systems applications.

For more information on compatibility, please refer to the Installation Manual accompanying the Rinnai Multi Split Outdoor Unit.

WARNING

-  **DO NOT** share the electrical outlet with other appliances. Improper or insufficient power supply can cause fire or electrical shock
-  This appliance is **NOT** intended for use by persons (including children) with reduced physical, sensory or mental capabilities, or lack of experience and knowledge unless they have been given supervision or instruction concerning use of the appliance by a person responsible for their safety. Children should be supervised to ensure that they **DO NOT** play with the appliance.

Installation Overview

3

INSTALLATION ORDER

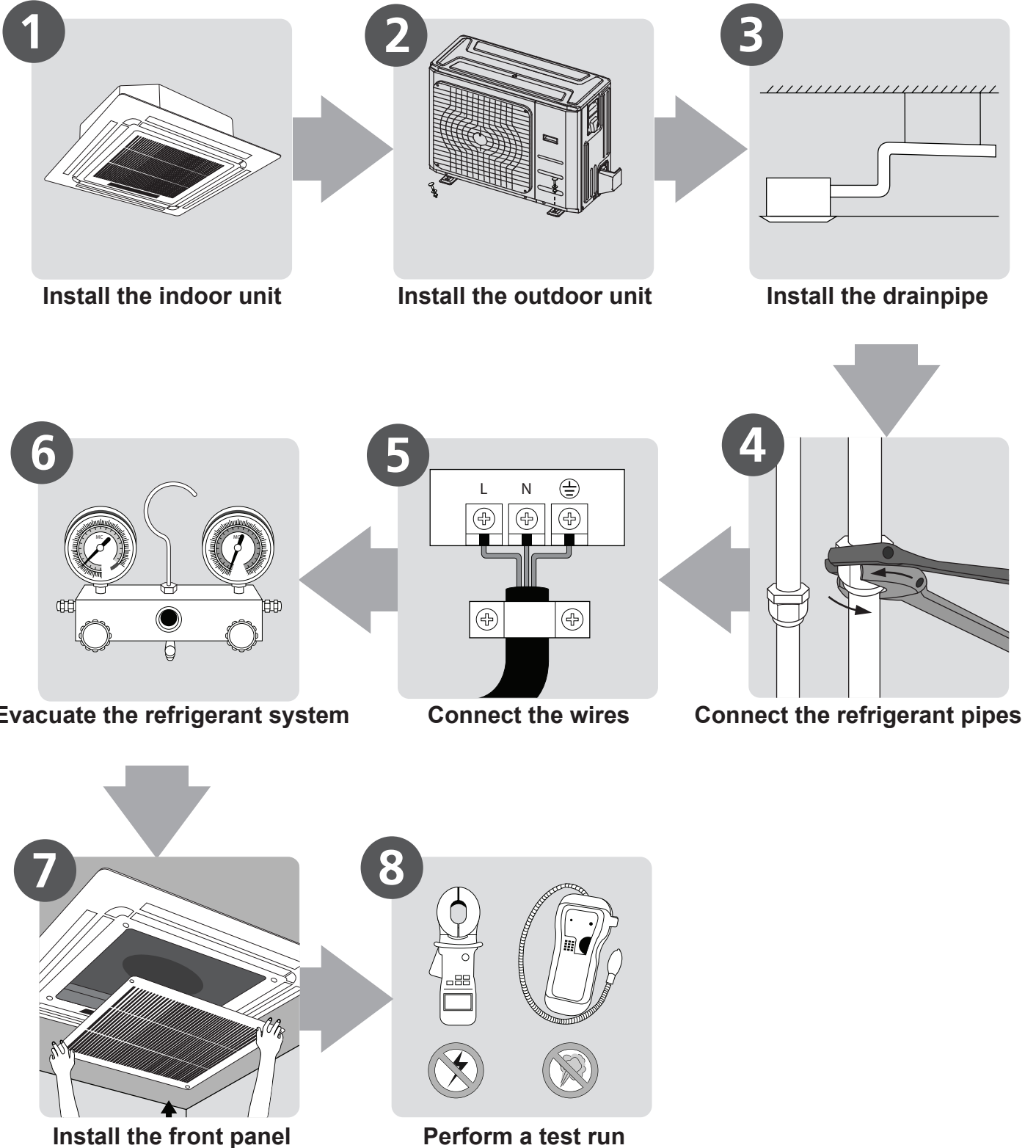

Indoor Unit Parts

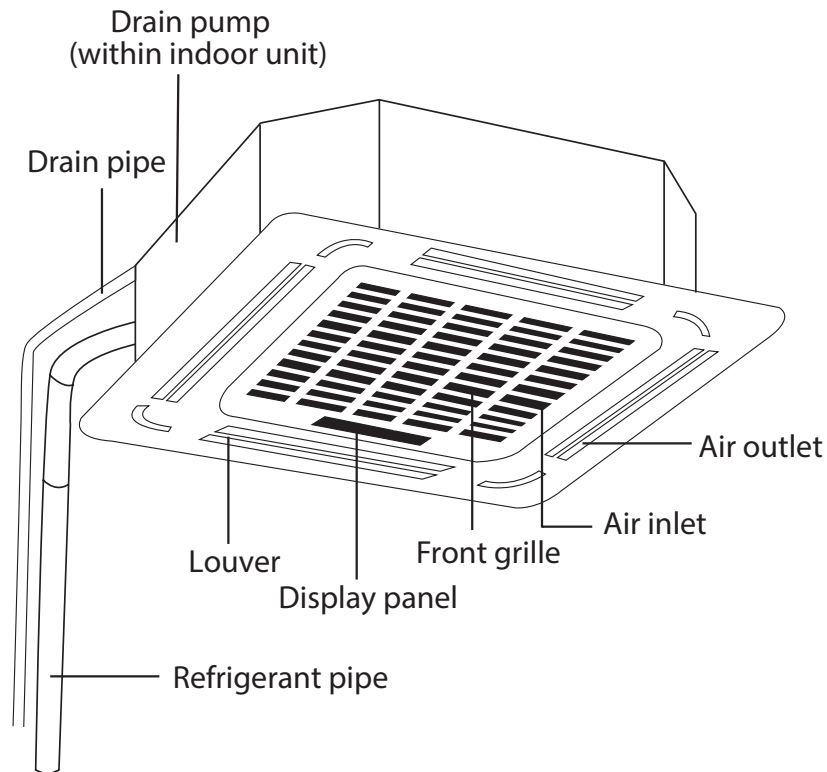

Fig. 4.1

Safety Precautions

! WARNING

- Securely install the indoor unit on a structure that can sustain its weight. If the structure is too weak the unit may fall causing personal injury, unit and property damage or death.
- Install the indoor unit at a height of more than 2.5m (8') above the floor.
- **DO NOT** install the indoor unit in the bathroom or laundry room as excessive moisture can short the unit and corrode the wiring.

! CAUTION

- Install the indoor and outdoor units, cables and wires at least 1m (3.2') from televisions or radios to prevent static or image distortion. Depending on the appliances, a 1m (3.2') distance may not be sufficient.
- If the indoor unit is installed on a metal part of the building, it must be electrically grounded.

Indoor Unit Installation Instructions

NOTE: Panel installation should be done after piping and wiring.

Step 1: Select installation location

The indoor unit should be installed in a location that meets the following requirements:

- ☑ The unit is at least 1m (39") from the nearest wall.
- ☑ There is enough room for installation and maintenance.
- ☑ There is enough room for the connecting pipe and drainpipe.
- ☑ The ceiling is horizontal and its structure can sustain the weight of the indoor unit.
- ☑ The air inlet and outlet are not impeded.
- ☑ The airflow can fill the entire room.
- ☑ There is no direct radiation from heaters.

! CAUTION

DO NOT install the unit in the following locations:

- ⊘ In areas with oil drilling or fracking
- ⊘ In coastal areas with high salt content in the air
- ⊘ In areas with caustic gases in the air, such as near hot springs
- ⊘ In areas with power fluctuations, such as factories
- ⊘ In enclosed spaces, such as cabinets
- ⊘ In kitchens that use natural gas
- ⊘ In areas with strong electromagnetic waves
- ⊘ In areas that store flammable materials or gas
- ⊘ In rooms with high humidity, such as bathrooms or laundry rooms

NOTE: Drainage should be considered when determining the space requirements for "H"

RECOMMENDED DISTANCES BETWEEN THE INDOOR UNIT AND THE CEILING

The distance between the mounted indoor unit and the internal ceiling should meet the following specifications. (See Fig. 4.2)

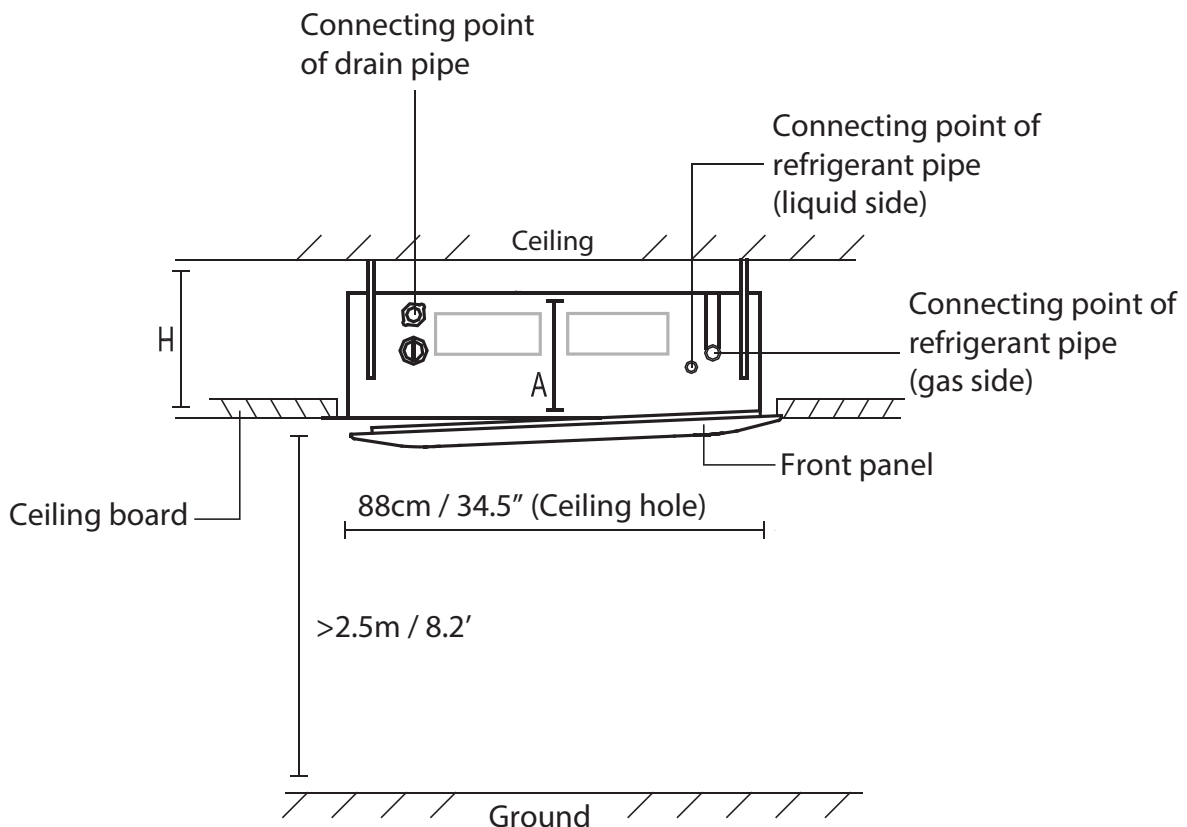

Fig. 4.2

Table 4.1:Distance from ceiling relative to height of indoor unit

MODEL	Length of A (mm/inch)	Length of H (mm/inch)
07	245	> 275
10	287	> 317
12	287	> 317
14	287	> 317

Step 2: Hang indoor unit.

1. Use the included paper template to cut a rectangular hole in the ceiling, leaving at least 1m (39") on all sides. The hole will be 88x88cm (34.5x34.5") big. Be sure to mark the areas where ceiling hook holes will be drilled.

Refrigerant piping side

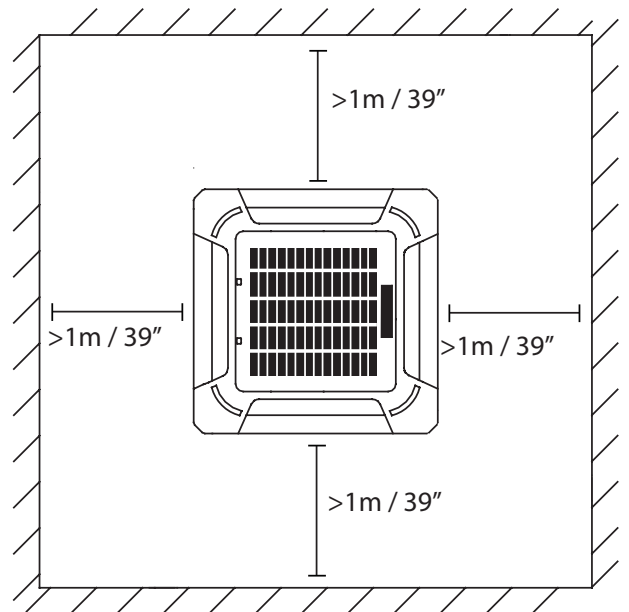
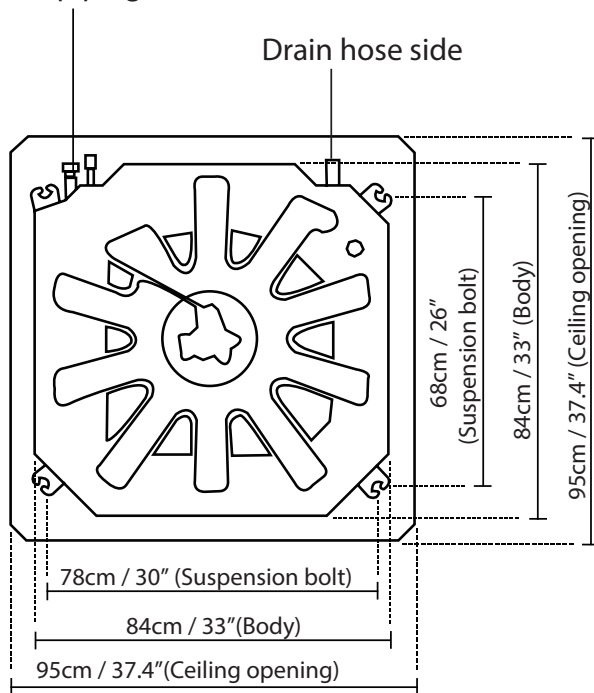

Fig. 4.3

! CAUTION

The unit body should align perfectly with the hole. Ensure that the unit and the hole are the same size before moving on.

2. Drill 4 holes 5cm (2") deep at the ceiling hook positions in the internal ceiling. Be sure to hold the drill at a 90°angle to the ceiling.
3. Using a hammer, insert the ceiling hooks into the pre-drilled holes. Secure the bolt using the included washers and nuts.
4. Install four suspension bolts (See Fig. 4.4).

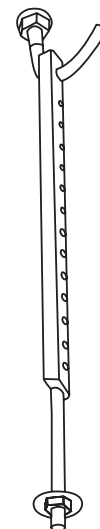

Fig. 4.4

5. Mount the indoor unit. You will need two people to lift and secure it. Insert suspension bolts into the unit's hanging holes. Fasten them using the included washers and nuts (See Fig. 4.5).

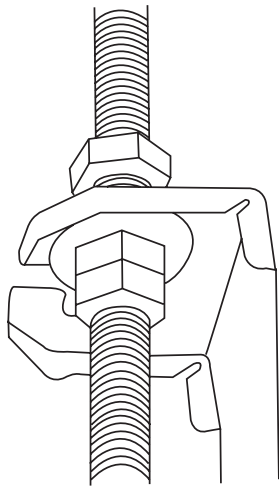

Fig. 4.5

NOTE: The bottom of the unit should be 10 - 18mm (0.4-0.7") higher than the ceiling board. Generally, L (indicated in Fig. 4.6) should be half the length of the suspension bolt or long enough to prevent the nuts from coming off.

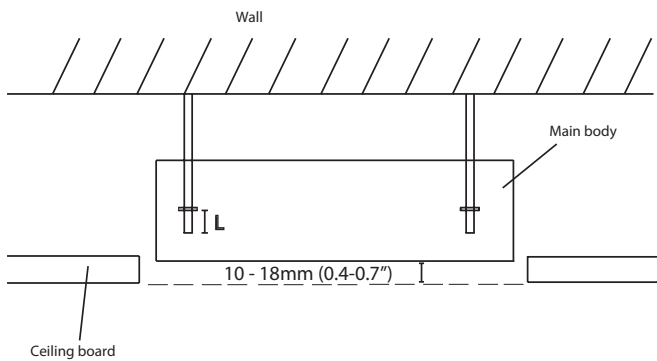

Fig. 4.6

! CAUTION

Ensure that the unit is completely level. Improper installation can cause the drain pipe to back up into the unit or water leakage.

NOTE: Ensure that the indoor unit is level. The unit is equipped with a built-in drain pump and float switch. If the unit is tilted against the direction of condensate flows (the drainpipe side is raised), the float switch may malfunction and cause water to leak.

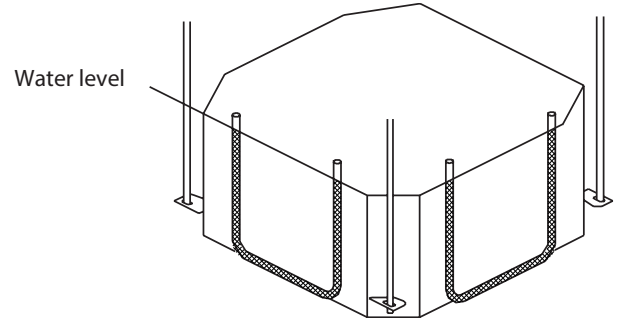

Fig. 4.7

NOTE FOR NEW HOME INSTALLATION

When installing the unit in a new home, the ceiling hooks can be embedded in advance. Make sure that the hooks do not come loose due to concrete shrinkage. After installing the indoor unit, fasten the installation paper template onto the unit with bolts (M6X12) to determine in advance the dimension and position of the opening on the ceiling. Follow the instructions above for the remainder of the installation.

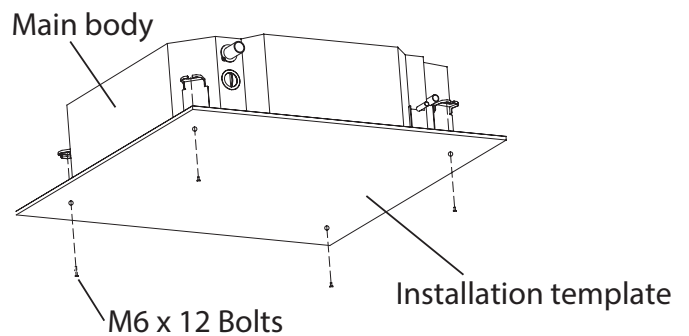

Fig. 4.8

Outdoor Unit Installation Instructions

Step 1: Select installation location.

The outdoor unit should be installed in the location that meets the following requirements:

- ☑ Place the outdoor unit as close to the indoor unit as possible.
- ☑ Ensure that there is enough room for installation and maintenance.
- ☑ The air inlet and outlet must not be obstructed or exposed to strong wind.
- ☑ Ensure the location of the unit will not be subject to snowdrifts, accumulation of leaves or other seasonal debris. If possible, provide an awning for the unit. Ensure the awning does not obstruct airflow.
- ☑ The installation area must be dry and well ventilated.
- ☑ There must be enough room to install the connecting pipes and cables and to access them for maintenance.

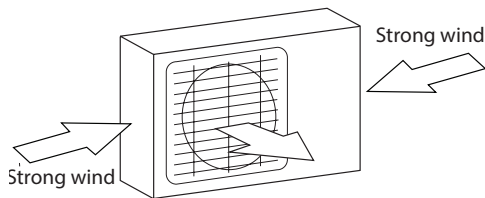

Fig. 5.1

- ☑ The area must be free of combustible gases and chemicals.
- ☑ The pipe length between the outdoor and indoor unit may not exceed the maximum allowable pipe length.
- ☑ If possible, **DO NOT** install the unit where it is exposed to direct sunlight.
- ☑ If possible, make sure the unit is located far away from your neighbors' property so that the noise from the unit will not disturb them.
- ☑ If the location is exposed to strong winds (for example: near a seaside), the unit must be placed against the wall to shelter it from the wind. If necessary, use an awning. (See Fig. 5.1 & 5.2)
- ☑ Install the indoor and outdoor units, cables and wires at least 1 meter from televisions or radios to prevent static or image distortion. Depending on the radio waves, a 1 meter distance may not be enough to eliminate all interference.

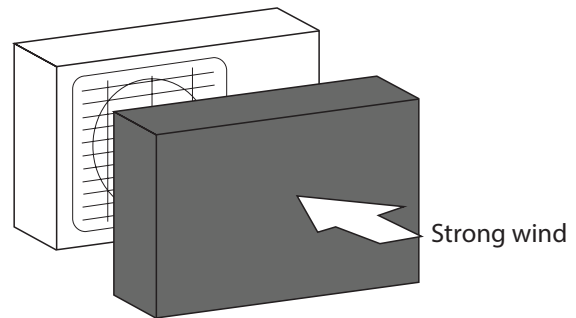

Fig. 5.2

Step 2: Install outdoor unit.

Fix the outdoor unit with anchor bolts (M10)

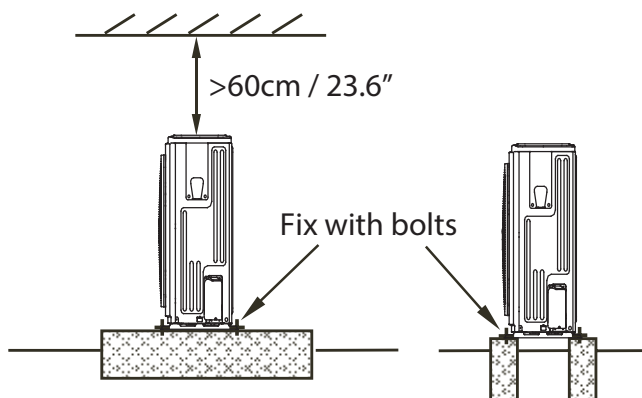

Fig. 5.3

! CAUTION

- Be sure to remove any obstacles that may block air circulation.
- Make sure you refer to Length Specifications to ensure there is enough room for installation and maintenance.

Outdoor Unit Dimensions

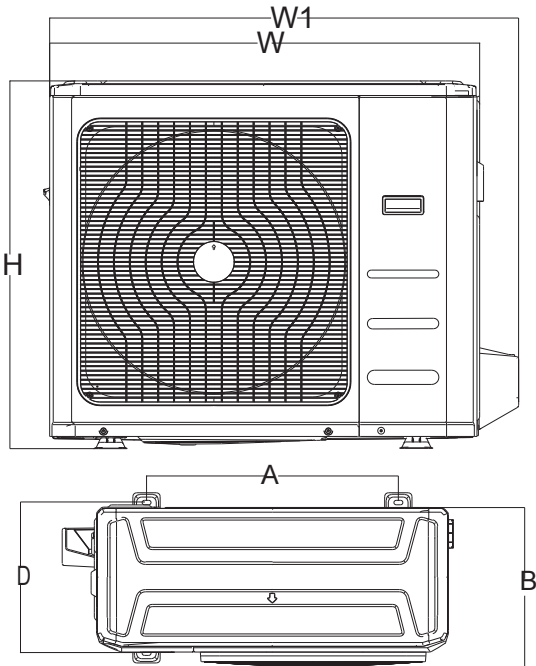

Fig.5.4

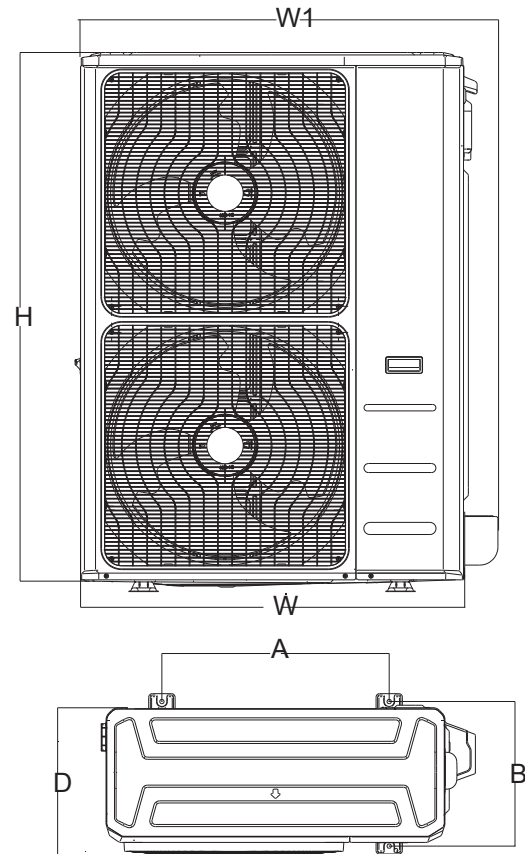

Fig. 5.5

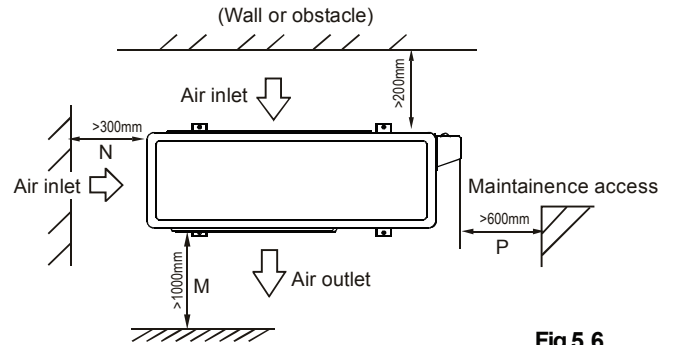

Fig.5.6



NOTE

All pictures and diagrams in this manual are indicative for explanatory purposes only. There may be differences between these and the products supplied, depending on the model. Actual unit specifications should be reviewed.

Moving and installation

- The unit centre of gravity is offset, so please be careful when lifting unit by hand or with slings.
- Do not hold or lift the unit by the condenser grilles. Equipment damage or personal injury may result.
- Do not touch the condenser fans by hand or other objects.
- Do not lay the unit down, or lean over more than 45° from vertical.
- Mount on a firm, stable base in accordance with the specification of the outdoor units. (Refer to Fig. 5.10).
- Fasten the mounting feet securely with bolts to prevent the unit from moving, or falling in strong winds. (Refer to Fig. below).

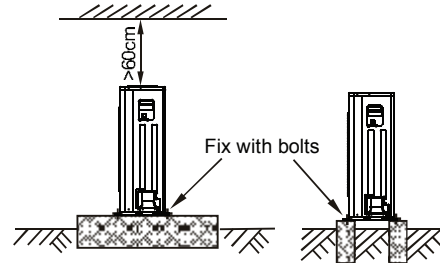

Fig.5.7



NOTE

All pictures and diagrams in this manual are indicative for explanatory purposes only. There may be differences between these and the products supplied, depending on the model. Actual unit specifications should be reviewed.

Table 5.4: Outdoor Units - (Unit: mm)

Models	W	D	H	W1	A	B
DONSR07Z72	946	410	810	1030	673	403
DONSR10Z72						
DONSR12Z72	952	415	1333	1045	634	404

NOTE: The minimum distance between the outdoor unit and walls described in the installation guide does not apply to airtight rooms. Be sure to keep the unit unobstructed in at least two of the three directions (M,N, P) (See Fig. 5.10)

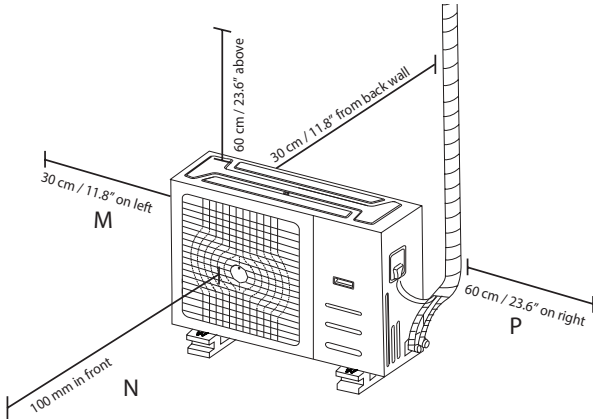

Fig. 5.10

Drain Joint Installation

Before bolting the outdoor unit in place, you must install the drain joint at the bottom of the unit. (See Fig. 5.11)

1. Fit the rubber seal on the end of the drain joint that will connect to the outdoor unit.
2. Insert the drain joint into the hole in the base pan of the unit.
3. Rotate the drain joint 90° until it clicks in place facing the front of the unit.
4. Connect a drain hose extension (not included) to the drain joint to redirect water from the unit during heating mode.

NOTE: Make sure the water drains to a safe location where it will not cause water damage or a slipping hazard.

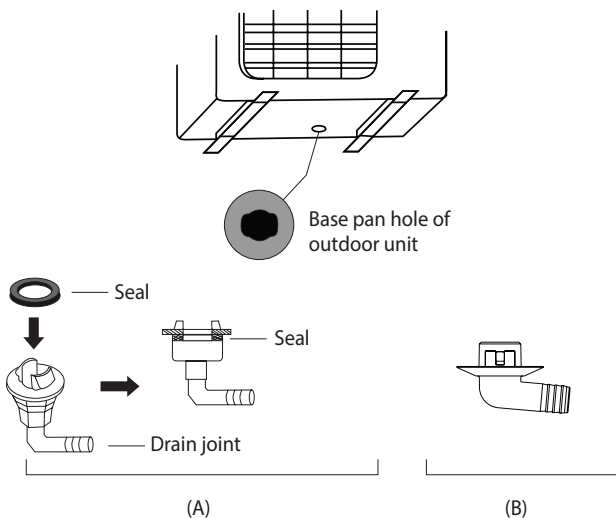

Fig. 5.11

Notes On Drilling Hole In Wall

You must drill a hole in the wall for the refrigerant piping, and the signal cable that will connect the indoor and outdoor units.

1. Determine the location of the wall hole based on the location of the outdoor unit.
2. Using a 65-mm (2.5") core drill, drill a hole in the wall.

NOTE: When drilling the wall hole, make sure to avoid wires, plumbing, and other sensitive components.

3. Place the protective wall cuff in the hole. This protects the edges of the hole and will help seal it when you finish the installation process.

Multiple Unit Installation

Table 5.5 The relations between H, A and L are as follows.

	L	A
L ≤ H	L ≤ 1/2H	25 cm / 9.8" or more
	1/2H < L ≤ H	30 cm / 11.8" or more
L > H	Can not be installed	

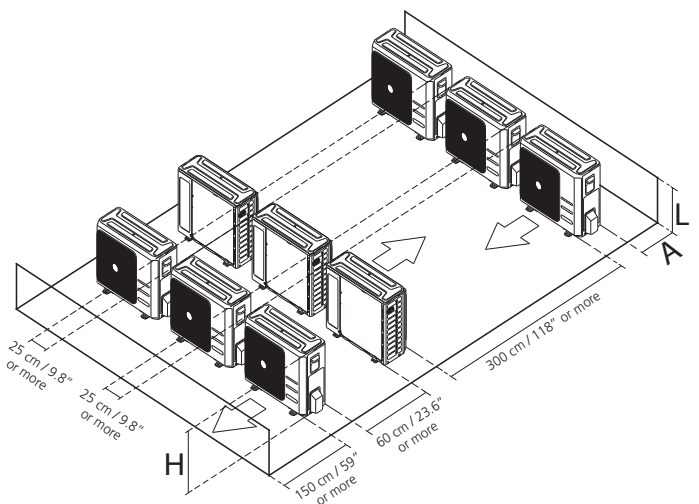

Fig. 5.12

Drain pipe Installation (Indoor unit has Drain Pump)

6

The drainpipe is used to drain water from the unit. Improper installation may cause unit and property damage.

CAUTION

- Insulate all piping to prevent condensation, which could lead to water damage.
- If the drainpipe is bent or installed incorrectly, water may leak and cause a malfunction of the water-level switch.
- In HEAT mode, the outdoor unit will discharge water. Ensure that the drain hose is placed in an appropriate area to avoid water damage & slippage due to frozen drain water.
- **DO NOT** pull the drainpipe forcefully as this could cause it to disconnect.

NOTE ON PURCHASING PIPES

This installation requires a polyethylene tube (outside diameter = 3.7-3.9cm, inside diameter = 3.2cm), which can be obtained at your local hardware store or from your dealer.

Indoor Drainpipe Installation

Install the drainpipe as shown in Figure 6.2.

1. Cover the drainpipe with heat insulation to prevent condensation and leakage.
2. Attach the mouth of the drain hose to the unit's outlet pipe. Sheath the mouth of the hose and clip it firmly with a pipe clamp. (Fig 6.1)

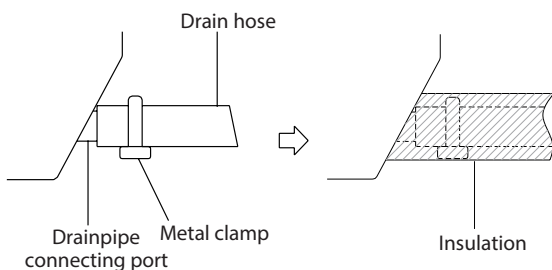

Fig. 6.1

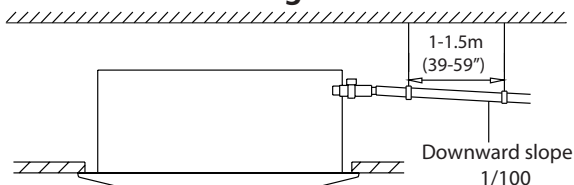

Fig. 6.2

NOTE : DRAINPIPE INSTALLATION

- When using an extended drainpipe, tighten the indoor connection with an additional protection tube to prevent it from pulling loose.
- The drainpipe should slope downward at a gradient of at least 1/100 to prevent water from flowing back into the air conditioner.
- To prevent the pipe from sagging, space hanging wires every 1-1.5m (40-59").
- If the outlet of the drainpipe is higher than the body's pump joint, provide a lift pipe for the exhaust outlet of the indoor unit. The lift pipe must be installed no higher than 75cm (29.5") from the ceiling board and the distance between the unit and the lift pipe must be less than 30cm (11.8"). Incorrect installation could cause water to flow back into the unit and flood.
- To prevent air bubbles, keep the drain hose level or slightly tiled up (<75mm / 3").

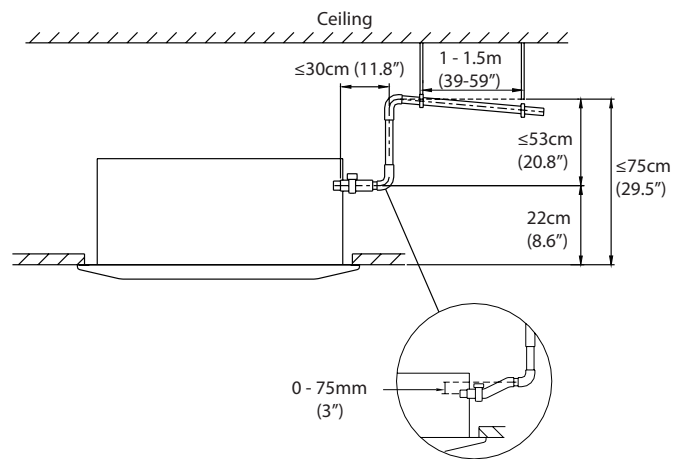

Fig. 6.3

NOTE: When connecting multiple drainpipes, install the pipes as shown in Fig 6.4.

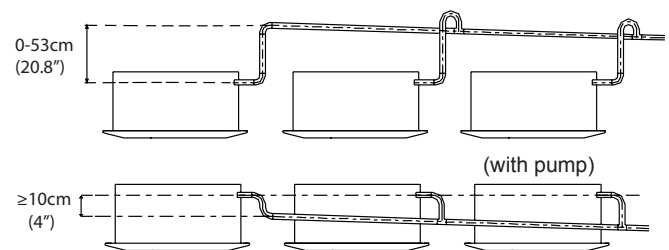

Fig. 6.4

- Using a core drill, drill a hole in the wall. Make sure that the hole is drilled at a slight downward angle, so that the outdoor end of the hole is lower than the indoor end by about 12mm (0.5"). This will ensure proper water drainage (See Fig. 6.5). Place the protective wall cuff in the hole. this protects the edges of the hole and will help seal it when you finish the installation process.

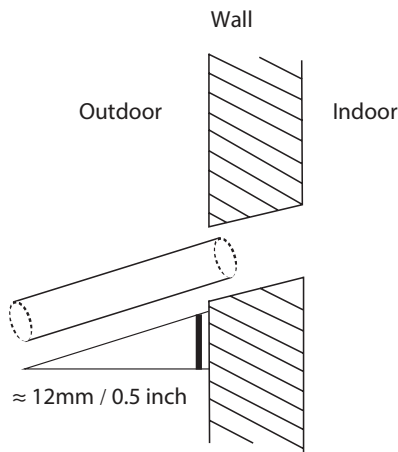

Fig. 6.5

NOTE: When drilling the wall hole, make sure to avoid wires, plumbing, and other sensitive components.

- Pass the drain hose through the wall hole. Make sure the water drains to a safe location where it will not cause water damage or a slipping hazard.

NOTE: The drainpipe outlet should be at least 5cm (1.9") above the ground. If it touches the ground, the unit may become blocked and malfunction. If you discharge the water directly into a sewer, make sure that the drain has a U or S pipe to catch odours that might otherwise come back into the house.

Refrigerant Piping Connection

Safety Precautions

WARNING

- All field piping must be completed by a licensed technician and must comply with the local and national regulations.
- When the air conditioner is installed in a small room, measures must be taken to prevent the refrigerant concentration in the room from exceeding the safety limit in the event of refrigerant leakage. If the refrigerant leaks and its concentration exceeds its proper limit, hazards due to lack of oxygen may result.
- When installing the refrigeration system, ensure that air, dust, moisture or foreign substances do not enter the refrigerant circuit. Contamination in the system may cause poor operating capacity, high pressure in the refrigeration cycle, resulting in personal injury.
- Ventilate the area immediately if there is refrigerant leakage during the installation. Leaked refrigerant gas is both toxic and flammable. Ensure there is no refrigerant leakage after completing the installation work.

Notes: Pipe Length and Elevation

Ensure that the length of the refrigerant pipe, the number of bends, and the drop height between the indoor and outdoor units meets the requirements shown in Table 7.1:

Table 7.1

MODEL	07	10	12	14
Maximum vertical separation between Indoor and Outdoor Units (m)	25	30	30	30
Maximum Pipe Length (m)	50	65	65	65
Pre-Charged Length (m)	15 m			

(Number of bends to be less than 10)

Refrigerant Piping Connection Instructions

! CAUTION

- The branching pipe must be installed horizontally. An angle of more than 10° may cause malfunction.
- **DO NOT** install the connecting pipe until both indoor and outdoor units have been installed.
- Insulate both the gas and liquid piping to prevent water leakage.

Step1: Cut pipes

When preparing refrigerant pipes, take extra care to cut and flare them properly. This will ensure efficient operation and minimize the need for future maintenance.

1. Measure the distance between the indoor and outdoor units.
2. Using a pipe cutter, cut the pipe a little longer than the measured distance.

! CAUTION

DO NOT deform pipe while cutting. Be extra careful not to damage, dent, or deform the pipe while cutting. This will drastically reduce the heating efficiency of the unit.

1. Make sure that the pipe is cut at a perfect 90° angle. Refer to Fig. 7.2 for examples of bad cuts

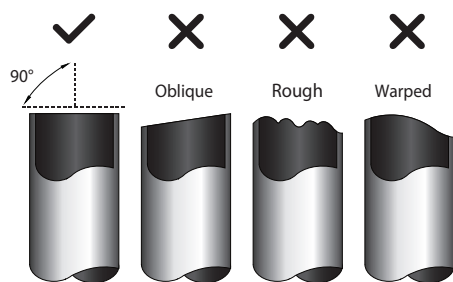

Fig. 7.2

Step2: Remove burrs

Burrs can affect the air-tight seal of refrigerant piping connection. They must be completely removed.

1. Hold the pipe at a downward angle to prevent burrs from falling into the pipe.
2. Using a reamer or deburring tool, remove all burrs from the cut section of the pipe.

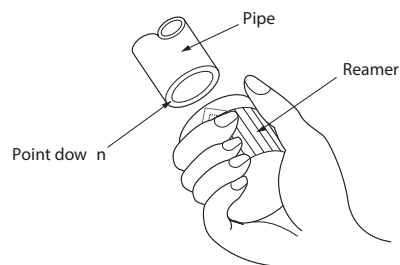

Fig. 7.3

Step 3: Flare pipe ends

Proper flaring is essential to achieve an airtight seal.

1. After removing burrs from cut pipe, seal the ends with PVC tape to prevent foreign materials from entering the pipe.
2. Sheath the pipe with insulating material.
3. Place flare nuts on both ends of pipe. Make sure they are facing in the right direction, because you can't put them on or change their direction after flaring. See Fig. 7.4

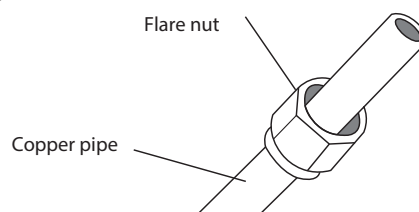

Fig. 7.4

4. Remove PVC tape from ends of pipe when ready to perform flaring work.
5. Clamp flare form on the end of the pipe. The end of the pipe must extend beyond the flare form.

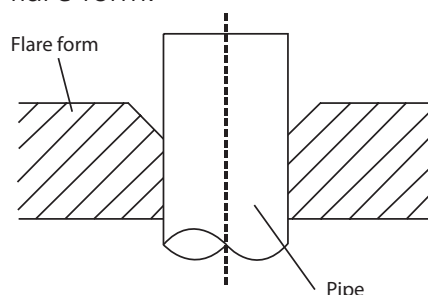

Fig. 7.5

6. Place flaring tool onto the form.
7. Turn the handle of the flaring tool clockwise until the pipe is fully flared. Flare the pipe in accordance with the dimensions shown in table 7.5.

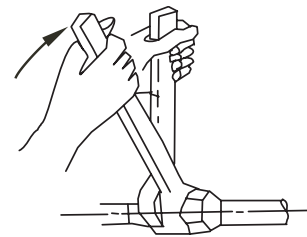

Fig. 7.8

Table 7.5: PIPING EXTENSION BEYOND FLARE FORM

Pipe gauge	Tightening torque (Unit: mm/Inch)	Flare dimension (A) (Unit: mm/Inch)		Flare shape
		Min.	Max.	
Ø 6.4	14.2-17.2 N.m (144-176 kgf.cm)	8.3/0.3	8.3/0.3	
Ø 9.5	32.7-39.9 N.m (333-407 kgf.cm)	12.4/0.48	12.4/0.48	
Ø 12.7	49.5-60.3 N.m (504-616 kgf.cm)	15.4/0.6	15.8/0.6	
Ø 15.9	61.8-75.4 N.m (630-770 kgf.cm)	18.6/0.7	19/0.74	
Ø 19.1	97.2-118.6 N.m (990-1210 kgf.cm)	22.9/0.9	23.3/0.91	
Ø 22	109.5-133.7 N.m (1117-1364 kgf.cm)	27/1.06	27.3/1.07	

Fig. 7.6

8. Remove the flaring tool and flare form, then inspect the end of the pipe for cracks and even flaring.

Step 4: Connect pipes

Connect the copper pipes to the indoor unit first, then connect it to the outdoor unit. You should first connect the low-pressure pipe, then the high-pressure pipe.

1. When connecting the flare nuts, apply a thin coat of refrigeration oil to the flared ends of the pipes.
2. Align the center of the two pipes that you will connect.

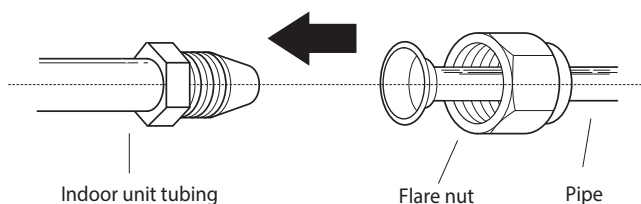

Fig. 7.7

3. Tighten the flare nut as tightly as possible by hand.
4. Using a spanner, grip the nut on the unit tubing.
5. While firmly gripping the nut, use a torque wrench to tighten the flare nut according to the torque values in table 7.5.

NOTE: Use both a spanner and a torque wrench when connecting or disconnecting pipes to/from the unit.

! CAUTION

- Ensure to wrap insulation around the piping. Direct contact with the bare piping may result in burns or frostbite.
- Make sure the pipe is properly connected. Over tightening may damage the bell mouth and under tightening may lead to leakage.

NOTE ON MINIMUM BEND RADIUS

Carefully bend the tubing in the middle according to the diagram below **DO NOT** bend the tubing more than 90° or more than 3 times.

Bend the pipe with thumb

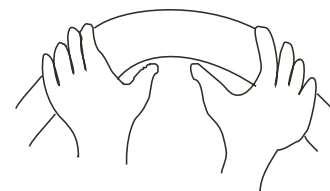

min-radius 10cm (3.9")

Fig. 7.9

6. After connecting the copper pipes to the indoor unit, wrap the power cable, signal cable and the piping together with binding tape.

NOTE: DO NOT intertwine signal cable with other wires. While bundling these items together, do not intertwine or cross the signal cable with any other wiring.

7. Thread this pipeline through the wall and connect it to the outdoor unit.
8. Insulate all the piping, including the valves of the outdoor unit.
9. Open the stop valves of the outdoor unit to start the flow of the refrigerant between the indoor and outdoor unit.

! CAUTION

Check to make sure there is no refrigerant leak after completing the installation work. If there is a refrigerant leak, ventilate the area immediately and evacuate the system (refer to the Air Evacuation section of this manual).

Safety Precautions

! WARNING

- Be sure to disconnect the power supply before working on the unit.
- All electrical wiring must be done accordance to local and National Regulations.
- Electrical wiring must be done by qualified technician. Improper connections may cause electrical malfunction, injury and fire.
- Connect the power cable to the terminals and fasten it with a clamp. An in secure connection may cause fire.
- Make sure that all wiring is done correctly and the control board cover is properly installed. Failure to do so can cause overheating at the connection points, fire, and electrical shock.
- Ensure that main supply connection is made with contact of gap at least 3mm.

! CAUTION

- Connect the outdoor wires before connecting the indoor wires.
- Make sure you ground the unit. The grounding wire should be away from gas pipes, water pipes, lightning rods, telephone or other grounding wires. Improper grounding may cause electrical shock.
- **DO NOT** connect the unit with the power source until all wiring and piping is completed.
- Make sure that you do not cross your electrical wiring with your signal wiring, as this can cause distortion & interference.

Follow these instructions to prevent distortion when the compressor starts:

- The unit must be connected to the main outlet. Normally, the power supply must have a low output impedance of 32 ohms.
- No other equipment should be connected to the same power circuit.
- The unit's power information can be found on the rating sticker on the product.

TAKE NOTE OF FUSE SPECIFICATIONS

The air conditioners circuit board (PCB) is designed with a fuse to provide overcurrent protection. The specifications of the fuse are printed on the circuit board, such as: T5A/250VAC, T10A/250VAC, etc.

Outdoor Unit Wiring

! WARNING

Before performing any electrical or wiring work, turn off the main power to the system.

1. Prepare the cable for connection
 - a. You must first choose the right cable size before preparing it for connection.
 - b. Using wire strippers, strip the rubber jacket from both ends of signal cable to reveal about 15cm of the wires inside.
 - c. Strip the insulation from the ends of the wires.
 - d. Using a wire crimper, crimp u-lugs on the ends of the wires.

NOTE

While connecting the wires, please strictly follow the wiring diagram (found inside the electrical box cover).

2. Remove the electric cover of the outdoor unit. If there is no cover on the outdoor unit, disassemble the bolts from the maintenance board and remove the protection board. (See fig 8.1)

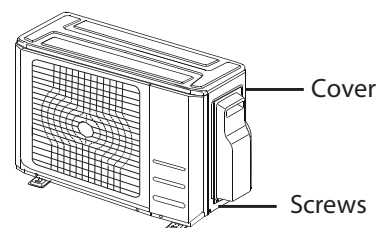

Fig. 8.1

3. Connect the u-lugs to the terminals Match the wire colours / labels with the labels on the terminal block, and firmly screw the u-lug of each wire to its corresponding terminal.
4. Clamp down the cable with designated cable clamp.
5. Insulate unused wires with electrical tape. Keep them away from any electrical or metal parts.
6. Reinstall the cover of the electric control box.

8. Wiring

Indoor Unit Wiring

1. Prepare the cable for connection
 - a. Using wire strippers, strip the rubber jacket from both ends of signal cable to reveal about 15cm of the wires inside.
 - b. Strip the insulation from the ends of the wires.
 - c. Using wire crimper, crimp the u-lugs to the ends of the wires.
2. Open the front panel of the indoor unit. Using a screwdriver, remove the cover of the electric control box on your indoor unit.
3. Thread the power cable and the signal cable through the wire outlet.

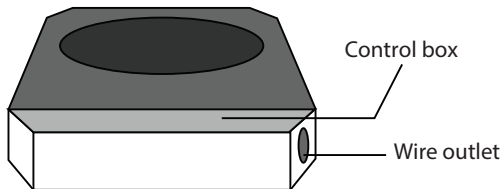
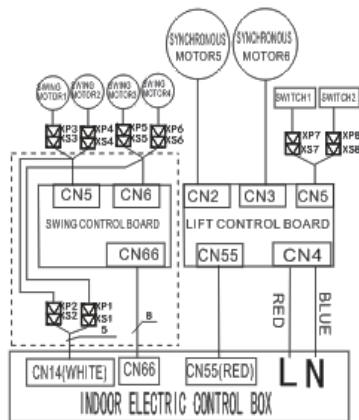

Fig 8.3

4. Connect the u-lugs to the terminals. Match the wire colors/labels with the labels on the terminal block, and firmly screw the u-lug of each wire to its corresponding terminal. Refer to the Serial Number and Wiring Diagram located on the cover of the electric control box.



NOTE: The wiring diagram is for explanation purpose only. The actual shape of the components may be different.

Fig 8.4 - Fascia Connections

! CAUTION

- While connecting the wires, please strictly follow the wiring diagram.
- The refrigerant circuit can become very hot. Keep the interconnection cable away from the copper tube.

5. Clamp down cable with the designated cable clamp to secure it in place. The cable should not be loose, and should not pull on the u-lugs.
6. Reinstall the electric box cover and the front panel of the indoor unit.

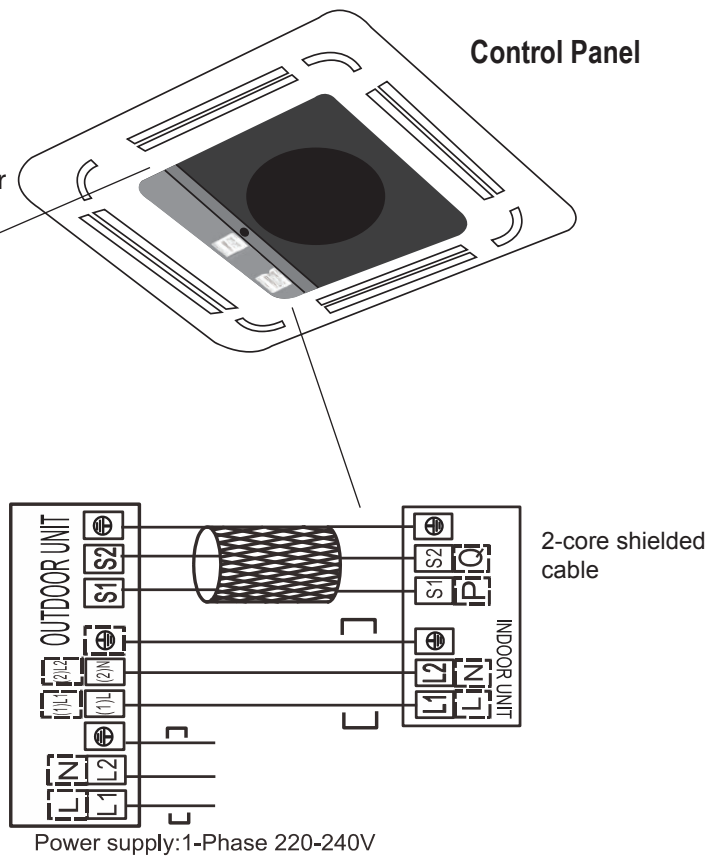

Fig 8.5 - Connective Wiring Diagram

Power Specification - Refer to Technical Specifications on following page.

Technical Specifications

Technical Specifications - SYSTEM		70	100	120	140	
Nominal Capacity	kW	7	10	12	14	
Power Supply (To Outdoor Unit)	V- Ph-Hz	220~240 - 1 - 50				
Maximum Input Power	W	3000	3900	5500	5500	
Maximum Input Current	A	16.0	21.0	26.0	26.0	
Recommended Circuit Breaker Size		25	25	32	32	
Cooling	Rated Capacity	kW	7.0	10.3	12.3	13.4
	Capacity Range		2.8 ~ 8.4	4.0 ~ 12.6	5.0 ~ 15.0	5.6 ~ 16.8
	Rated Input Power	W	2116	3110	3690	4079
	Stand By Power		10	10	10	10
	Rated Input Current	A	9.4	13.7	16.1	17.8
	AEER	W/W	3.26	3.26	3.31	3.26
	Star Rating	-	2.0	2.0	2.0	2.0
Heating	Rated Capacity	kW	7.7	10.4	14.2	14.9
	Capacity Range		3.0 ~ 9.0	4.2 ~ 12.9	5.2 ~ 15.6	5.8 ~ 17.5
	Rated Input Power	W	2250	2980	4030	4411
	Stand By Power		10	10	10	10
	Rated Input Current	A	10.0	13.1	17.7	19.2
	ACOP	W/W	3.36	3.46	3.49	3.36
	Star Rating	-	2.0	2.0	2.0	2.0
Indoor Unit		CIN070R	CIN100R	CIN120R	CIN140R	
Fascia Panel	Model No.	CINFAS				
Rated Input	W	246	250	250	250	
Air Flow (Hi / Med / Lo)	L/s	439 / 333 / 278	639 / 556 / 500	639 / 556 / 500	639 / 556 / 500	
Sound Pressure Level @ 1.4m (Hi / Med / Lo)	dB(A)	49 / 45 / 41	54 / 51 / 48	54 / 51 / 48	54 / 51 / 48	
Dimensions	Net - Body (W x D x H)	mm	840 x 840 x 245	840 x 840 x 287	840 x 840 x 287	840 x 840 x 287
	Gross - Body (W x D x H)		900 x 900 x 265	900 x 900 x 300	900 x 900 x 300	900 x 900 x 300
	Net - Fascia (W x D x H)		950 x 950 x 55	950 x 950 x 55	950 x 950 x 55	950 x 950 x 55
	Gross - Fascia (W x D x H)		1035 x 1035 x 90	1035 x 1035 x 90	1035 x 1035 x 90	1035 x 1035 x 90
	Net / Gross Weight - Body	kg	24 / 28	28.7 / 32.8	28.7 / 32.8	28.7 / 32.8
	Net / Gross Weight - Fascia		5 / 8	5 / 8	5 / 8	5 / 8
Condensate Drain Pipe Diameter	mm	ODφ32	ODφ32	ODφ32	ODφ32	
Refrigerant Piping Liquid / Gas Connections		φ9.52/φ15.9	φ9.52/φ15.9	φ9.52/φ15.9	φ9.52/φ15.9	
Standard Controller	Type	Wireless Remote				
Operating Range	°C	Cooling: 17 ~ 32. Heating: 0 ~ 30				
Outdoor Unit		DONSR07Z72	DONSR10Z72	DONSR12Z72	DONSR14Z72	
Power Supply	V- Ph-Hz	220~240 - 1 - 50				
Maximum Input Power	W	3000	3900	5500	5500	
Maximum Input Current	A	16.0	21.0	26.0	26.0	
Starting Current		2.5	3.0	3.5	4.0	
Compressor	Type	Twin Rotary				
Air Flow	L/s	972	1528	1944	2000	
Sound Pressure Level @ 1m	dB(A)	58	61	62	62	
Sound Power Level		69	70	71	71	
Dimensions	Net (W x D x H)	mm	946 x 410 x 810	946 x 410 x 810	952 x 415 x 1333	952 x 415 x 1333
	Gross (W x D x H)		1090 x 500 x 865	1090 x 500 x 865	1095 x 495 x 1480	1095 x 495 x 1480
	Net / Gross Weight	kg	61 / 66.5	68.5 / 74	100 / 114	116 / 130
Refrigerant Piping	Type	R410A				
	Charged Volume	kg	2.90	3.80	4.50	4.90
	Design Pressure	MPa	4.2 / 1.5	4.2 / 1.5	4.2 / 1.5	4.2 / 1.5
	Pre-Charged Length	m	15	15	15	15
	Charge Adjustment (Add or Remove)	g/m	30	30	30	30
Refrigerant Piping	Liquid / Gas Connections	mm	φ9.52 / φ15.9	φ9.52 / φ15.9	φ9.52/φ15.9	φ9.52/φ15.9
	Maximum Pipe Length	m	50	65	65	65
	Maximum Vertical Separation		25	30	30	30
Ambient Temperature Limits	°C	Cooling: -15 ~ 50. Heating -15 ~ 24				
Capacities rated in accordance with AS3823 with 5m charged length. With our policy of continuous improvement, we reserve the right to change, or discontinue at any time, specifications or designs without notice.						

9 April 2018

Safety Precautions

! CAUTION

- Use a vacuum pump with a gauge reading lower than -0.1MPa and an air discharge capacity above 40L/min.
- The outdoor unit does not need vacuuming. **DO NOT** open the outdoor unit's gas and liquid stop valves.
- Ensure that the Compound Meter reads -0.1MPa or below after 2 hours. If after three hours of operation and the gauge reading is still above -0.1MPa, check if there is a gas leak or water inside the pipe. If there is no leakage, perform another evacuation for 1 or 2 hours.
- **DO NOT** use refrigerant gas to evacuate the system.

Evacuation Instructions

Before using manifold gauge and vacuum pump, read their operation manuals to familiarize yourself with how to use them properly.

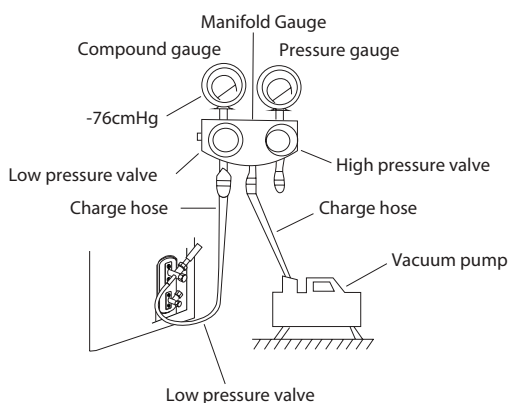

Fig. 9.1

1. Connect the charge hose of the manifold gauge to service port on the outdoor unit's low pressure valve.
2. Connect another charge hose from the manifold gauge to the vacuum pump.
3. Open the Low Pressure side of the manifold gauge. Keep the High Pressure side closed.

4. Turn on the vacuum pump to evacuate the system.
5. Run the vacuum for at least 15 minutes, or until the Compound Meter reads -76cmHG (-1x105Pa).
6. Close the Low Pressure side of the manifold gauge, and turn off the vacuum pump.
7. Wait for 5 minutes, then check that there has been no change in system pressure.

NOTE If there is no change in system pressure, unscrew the cap from the packed valve (high pressure valve). If there is a change in system pressure, there may be a gas leak.

8. Insert hexagonal wrench into the packed valve (high pressure valve) and open the valve by turning the wrench in a 1/4 counterclockwise turn. Listen for gas to exit the system, then close the valve after 5 seconds.

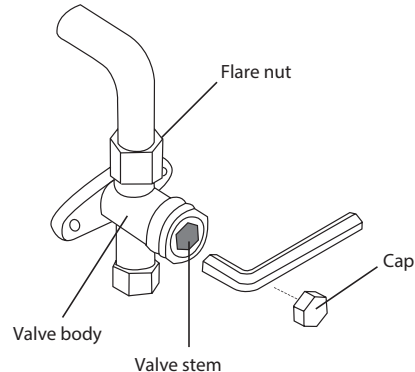

Fig. 9.2

9. Watch the Pressure Gauge for one minute to make sure that there is no change in pressure. The Pressure Gauge should read slightly higher than atmospheric pressure.
10. Remove the charge hose from the service port.
11. Using hexagonal wrench, fully open both the high pressure and low pressure valves.

OPEN VALVE STEMS GENTLY

When opening valve stems, turn the hexagonal wrench until it hits against the stopper. **DO NOT** try to force the valve to open further.

12. Tighten valve caps by hand, then tighten it using the proper tool.

Note On Adjusting Refrigerant

! CAUTION

- Refrigerant charging must be performed after wiring, vacuuming and the leak test.
- **DO NOT** exceed the maximum allowable quantity of refrigerant or over charge the system. Doing so can damage or impact the unit's function.
- Charging with unsuitable substances may cause explosions or accidents. Ensure that the appropriate refrigerant is used.
- Refrigerant containers must be opened slowly. Always use protective gear when charging the system.
- **DO NOT** mix refrigerants types.

The outdoor unit is pre-charged with refrigerant for a 15 m pipe run. Please calculate any adjustment to refrigerant required according to the diameter and length of the liquid line pipe of the indoor/outdoor connection.

Table 9.1

System Refrigerant Adjustment		
Less than 15 m	REMOVE Refrigerant	30g/m for Ø9.52 liquid line
More than 15 m	ADD Refrigerant	

Panel Installation

10

! CAUTION

DO NOT place the panel facedown on the floor, against a wall, or on uneven surfaces.

Step 1: Remove the front grille.

1. Push both of the tabs towards the middle simultaneously to unlock the hook on the grille.
2. Hold the grille at a 45° angle, lift it up slightly and detach it from the main body.

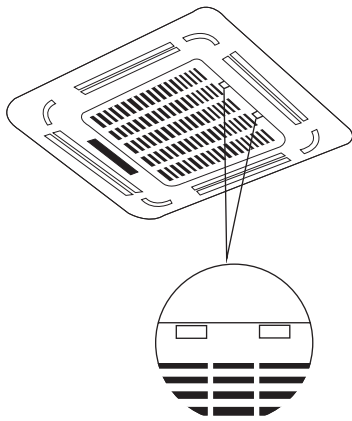

Fig. 10.1

Step 2: Remove the installation covers at the four corners by sliding them outwards.

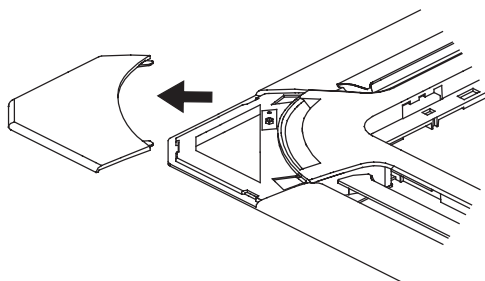

Fig. 10.2

Step 3: Install the panel

Align the front panel to the main body, taking into account the position of the piping and drain sides. Hang the four latches of the decorative panel to the hooks of the indoor unit. Tighten the panel hook screws evenly at the four corners. (See Fig 10.3)

NOTE: Tighten the screws until the thickness of the sponge between the main body and the panel reduces to 4-6mm (0.2-0.3"). The edge of the panel should be in contact with the ceiling well.

Adjust the panel by turning it to the arrowed direction shown in Fig 10.3 so that the ceiling opening is completely covered.

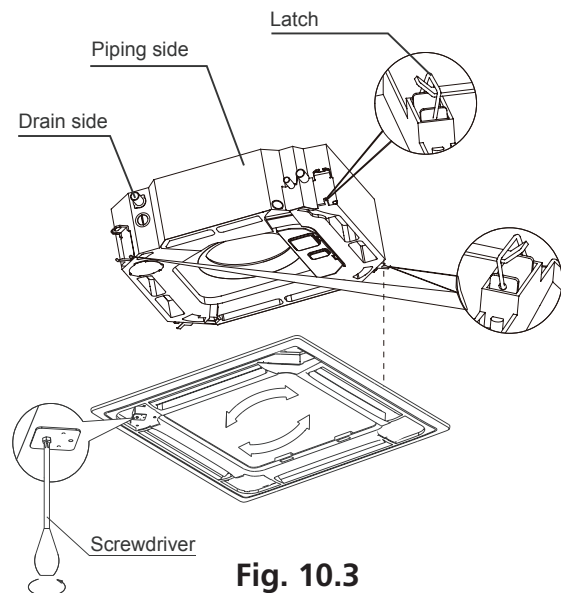

Fig. 10.3

1. Connect the two louver motor connectors to the corresponding wires in the control box.

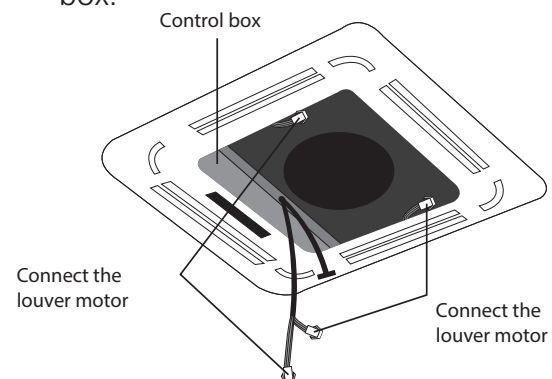

Fig. 10.4

2. Remove foam stops from inside the fan.
3. Attach the side of the front grille to the panel.
4. Connect the display panel cable to the corresponding wire on the main body.

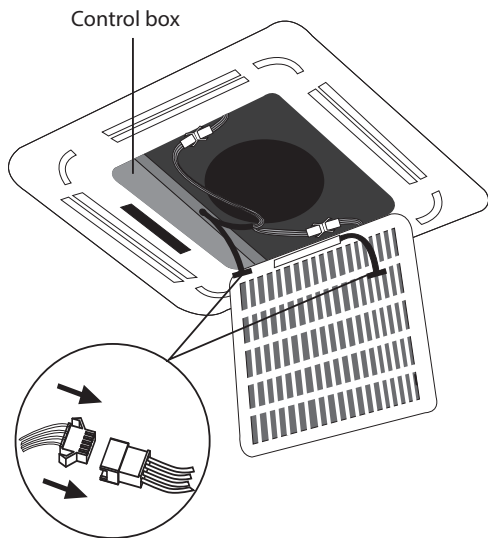

Fig. 10.5

! CAUTION

Failure to tighten screws can cause water leakage.

5. Close the front grille.
6. Fasten the installation covers at all four corners by pushing them inwards. (See Fig.10.6)

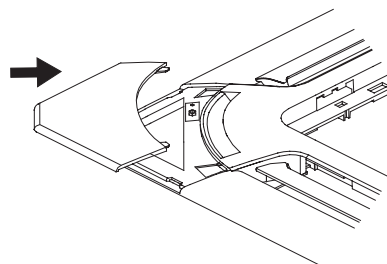

Fig. 10.6

NOTE: If the height of the indoor unit needs to be adjusted, you can do so through the openings at the panel's four corners. Make sure that the internal wiring and drainpipe are not affected by this adjustment.

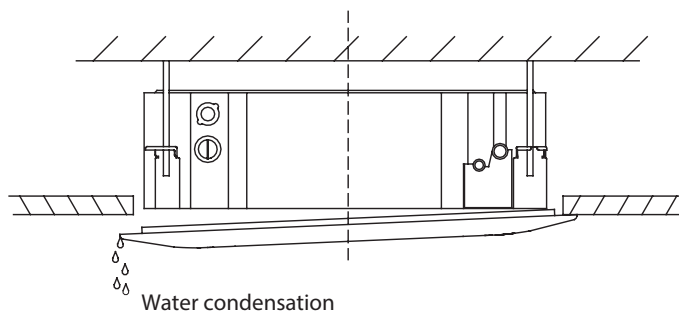

Fig. 10.7

! CAUTION

If the unit is not hung correctly and a gap exists, the unit's height must be adjusted to ensure proper function. The unit's height can be adjusted by loosening the upper nut, and adjusting the lower nut.

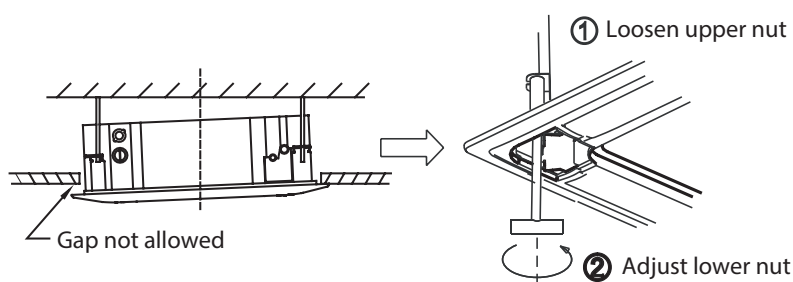

Fig. 10.8

Before Test Run

A test run must be performed after the entire system has been completely installed. Confirm the following points before performing the test:

- a) The indoor and outdoor units are properly installed.
- b) Piping and wiring are properly connected.
- c) Ensure that there are no obstacles near the inlet and outlet of the unit that might cause poor performance or product malfunction.
- d) The refrigeration system does not leak.
- e) The drainage system is unimpeded and draining to a safe location.
- f) The heating insulation is properly installed.
- g) The grounding wires are properly connected.
- h) The length of the piping and the added refrigerant stow capacity have been recorded.
- i) The power voltage is the correct voltage for the air conditioner.

! CAUTION

Failure to perform the test run may result in unit damage, property damage or personal injury.

Test Run Instructions

1. Open both the liquid and gas stop valves.
2. Turn on the main power switch and allow the unit to warm up.
3. Set the air conditioner to COOL mode.
4. For the Indoor Unit
 - a. Ensure the remote control and its buttons work properly.
 - b. Ensure the louvers move properly and can be changed using the remote control.
 - c. Double check to see if the room temperature is being registered correctly.
 - d. Ensure the indicators on the remote control and the display panel on the indoor unit work properly.
 - e. Ensure the manual buttons on the indoor unit works properly.

- f. Check to see that the drainage system is unimpeded and draining smoothly.
 - g. Ensure there is no vibration or abnormal noise during operation.
5. For the Outdoor Unit
 - a. Check to see if the refrigeration system is leaking.
 - b. Make sure there is no vibration or abnormal noise during operation.
 - c. Ensure the wind, noise, and water generated by the unit do not disturb your neighbors or pose a safety hazard.
 6. Drainage Test
 - a. Ensure the drainpipe flows smoothly. New buildings should perform this test before finishing the ceiling.
 - b. Remove the test cover. Add 2,000ml of water to the tank through the attached tube.
 - c. Turn on the main power switch and run the air conditioner in COOL mode.
 - d. Listen to the sound of the drain pump to see if it makes any unusual noises.
 - e. Check to see that the water is discharged. It may take up to one minute before the unit begins to drain depending on the drainpipe.
 - f. Make sure that there are no leaks in any of the piping.
 - g. **Stop the air conditioner. Turn off the main power switch and reinstall the test cover.**

NOTE: If the unit malfunctions or does not operate according to your expectations, please refer to the Troubleshooting section of the Owner's Manual before calling customer service.

Rinnai

Rinnai Australia Pty. Ltd.

ABN 74 005 138 769

**100 Atlantic Drive
Keysborough, Victoria 3173**

**P.O. Box 460
Braeside, Victoria 3195**

AU45204

Rinnai has a Service and Spare Parts network with personnel who are fully trained and equipped to give the best service on your Rinnai appliance. If your appliance requires service, please call our National Help Line. Rinnai recommends that this appliance be serviced at least every 2 years.

With our policy of continuous improvement, we reserve the right to change, or discontinue at any time, specifications or designs without notice.

Product Sales & Service National Help Line

Tel: **1300 555 545*** Fax: **1300 555 655**

*Monday to Friday, 8.00am to 5.30pm EST

For further information visit **www.rinnai.com.au**
or email **enquiry@rinnai.com.au**