

MODELS

System	Indoor	Outdoor
HSNRVX25	HINRVX25	HONRVX25
HSNRVX35	HINRVX35	HONRVX35
HSNRVX50	HINRVX50	HONRVX50
HSNRVX70	HINRVX70	HONRVX70

REFRIGERANT  
**R32**

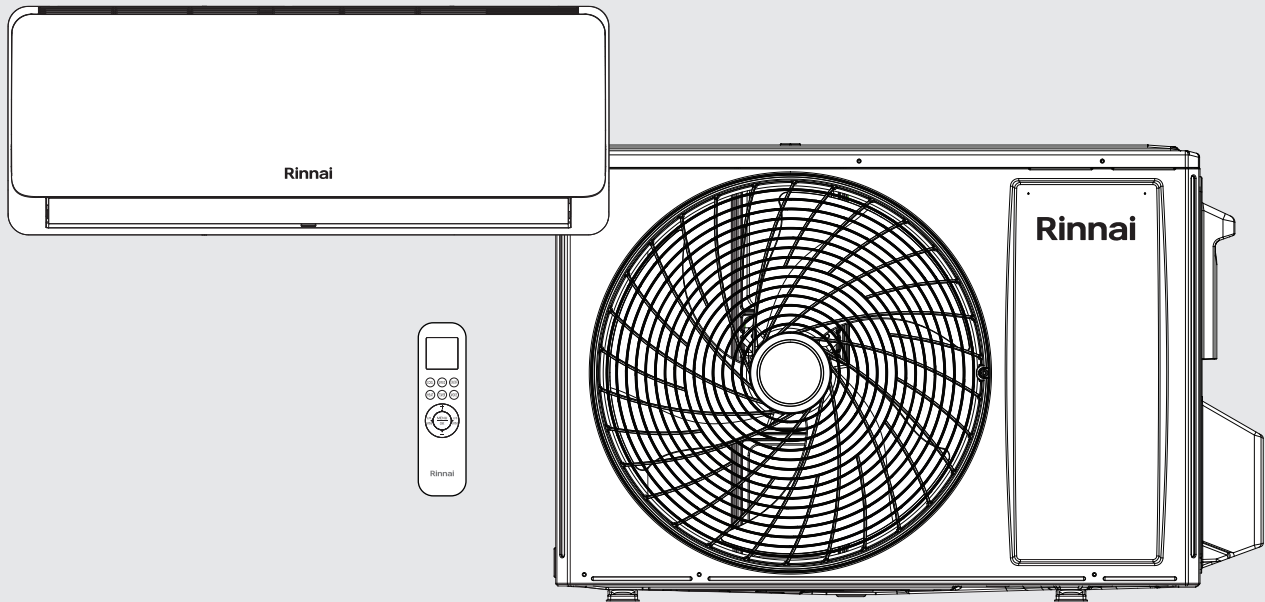

# VX Series Split Type Wall Mounted Air Conditioner Installation Manual

# Rinnai

This appliance must be installed in accordance with:

- Manufacturer's Installation Instructions
- Current AS/NZS 3000, AS/NZS 5141, AS/NZS 5149
- Local regulations, including local OH&S requirements, and Municipal Building Codes, including the National Construction Code (NCC).

This appliance must be installed, maintained and removed only by an Authorised Person. Rinnai recommends that this appliance be serviced once a year.

For continued safety of this appliance it must be installed and maintained in accordance with the manufacturer's instructions.



# TABLE OF CONTENTS

<b>Warnings and Important Information</b>	<b>5</b>
<b>Disposal Guidelines</b> .....	<b>6</b>
<b>Operating range</b> .....	<b>9</b>
Operation Range Limitations .....	9
Heating .....	9
Turning Off .....	9
<b>Operating the Air Conditioner Without the Remote Control</b> .....	<b>9</b>
<b>Installation General</b>	<b>10</b>
<b>Contents Checklist</b> .....	<b>10</b>
<b>Appliance Components</b> .....	<b>10</b>
<b>Weights &amp; Dimensions</b> .....	<b>10</b>
<b>Description</b>	<b>11</b>
<b>Installation Diagram - Indoor / Outdoor Parts</b> .....	<b>11</b>
<b>Location</b>	<b>12</b>
<b>Indoor Unit</b> .....	<b>12</b>
<b>Outdoor Unit</b> .....	<b>12</b>
<b>Pipe Length &amp; Elevation Limits</b> .....	<b>12</b>
<b>Installation</b>	<b>13</b>
<b>Indoor Unit Installation</b> .....	<b>13</b>
Wall Mounting Plate .....	13
Wall Penetration .....	14
Refrigerant Pipe Connection .....	14
Indoor Unit Electrical Connections .....	15
Mounting the Indoor Unit (Wall Installation) .....	15
Water Drainage Piping .....	16
<b>Refrigerant Pipes</b> .....	<b>17</b>
Flaring .....	17
Piping Works & Flaring Technique .....	17
Install Refrigerant Piping .....	17
Install the Connection Pipe .....	18
<b>Outdoor Unit Installation</b> .....	<b>19</b>
Outdoor Installation Location .....	19
Coastal Installation (Outdoor unit) .....	20
Outdoor Unit Electrical Connections .....	20
DRED Connection (optional) .....	21
<b>Outdoor Condensate Drainage</b> .....	<b>22</b>

**TABLE OF CONTENTS**

<b>Installing Refrigerant Pipe Connection</b> .....	<b>22</b>
<b>Air Purging &amp; Leakage Test</b> .....	<b>23</b>
Evacuation Vacuum Method / Leak Test .....	23
Adding Refrigerant for Longer Line Length .....	23
<b>Final Checklist</b> .....	<b>24</b>
<b>Specifications</b>	<b>25</b>
<b>Contacts</b>	<b>28</b>

# WARNINGS AND IMPORTANT INFORMATION



## READ ALL INSTRUCTIONS BEFORE USING THE APPLIANCE.

Always comply with the following precautions to avoid dangerous situations and to ensure optimum performance.

Failure to carefully read and follow all instructions in this manual can result in equipment malfunction, property damage, personal injury and/or death.

**DANGER:** Indicates an imminently hazardous situation which, if not avoided, will result in personal injury or death.

**WARNINGS:** Indicates a potentially hazardous situation which, if not avoided, could result in personal injury or death.



**CAUTIONS:** Indicates a potentially hazardous situation which, if not avoided, could result in minor or moderate injury or damage to the appliance. It may also be used to alert against unsafe practices.



## REGULATORY

This appliance shall be installed in accordance with:

Manufacturer's Installation Instructions.

Current AS/NZS 3000, AS/NZS 5141, AS/NZS 5149.

Local regulations, including local OH&S requirements, and Municipal Building Codes, including the National Construction Code (NCC).

This appliance must be installed, maintained and removed **ONLY** by an Authorised Person.

For continued safety of this appliance it must be installed and maintained in accordance with the manufacturers instructions.

This appliance uses R32 refrigerant. If incorrectly treated, may cause serious harm to the human body or surroundings.

This appliance is heavy, use 2 people or mechanical lifting device. Improper lifting may result in serious injury.

Take care when opening or unpacking this appliance. Failure to do so may result in serious injury or product failure.

**DO NOT** modify the electrical wiring of this appliance. If the control power wiring is damaged or deteriorated then it must be replaced by an authorised person. Failure to do so may result in electric shock, fire, serious injury or product failure.

**DO NOT** install the air conditioner on an unstable or non level surface or where there may be a danger of it falling. It may result in death, serious injury, or product failure.

**DO NOT** install the outdoor unit where noise may cause nuisance.

**DO NOT** install the outdoor unit where it will be exposed to sea wind (salt spray) as this will reduce durability.



## MANDATORY INSPECTION PRIOR TO INSTALLATION

Immediately report any damage or discrepancies to the Supplier of the appliance. This appliance was inspected and tested at the time of manufacture and packaging, and released for transportation without known damage. Upon receipt, inspect the exterior for evidence of rough handling in shipment. Ensure that the appliance is labelled correctly for the gas and electrical supply, and/or other services it is intended to be connected to.

For safety and warranty purposes, appliances that may be damaged or incorrect **MUST NOT** be installed or operated under any circumstances. Installation of damaged or incorrect appliances may contravene local government regulations. Rinnai disclaims any liability or responsibility whatsoever in relation to the installation or operation of damaged or incorrect appliances.

**DISPOSAL GUIDELINES**

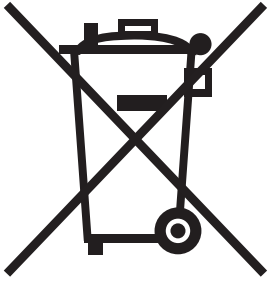

This appliance contains refrigerant and other potentially hazardous materials. When disposing of this appliance, the law requires special collection and treatment. Contact your local government for information regarding the collection systems available.

**DO NOT** dispose of this product as household waste or unsorted municipal waste.



**Special notice – If electrical appliances are disposed of in landfills or dumps, hazardous substances can leak into the groundwater and get into the food chain, damaging your health and well-being.**



**A NOTE ON ILLUSTRATIONS**

The illustrations used in this manual are for explanatory purposes only and the shape of your indoor unit may vary slightly from that which is shown in this manual.



**INSTALLATION**

This appliance shall be installed in accordance with local electrical safety regulations by an authorised person such as a licensed electrician.

This appliance is a Type 1 Electrical Appliance.

**Make sure the live wire, neutral wire and earth wire in the power socket are properly connected. Inadequate or incorrect electrical connections may cause fire or electric shock.**

The yellow-green wire in air conditioner is the earthing wire which cannot be used for other purposes. Improper earthing may cause electric shock.

The circuit breaker must have the functions of magnetic tripping and heat tripping to prevent short circuit and overload.

Use a standard circuit breaker and fuse conforming with the rating of the appliances.

**The unit must be earthed in accordance with local regulations.**

**Connect all wiring tightly. Failure to do so may result in electric shock or product failure.**

**DO NOT** supply power to the unit until all wiring and tubing are completed.

Select an installation location where the components can be mounted securely and accessible for service and replacement.

Make sure tubing is properly insulated to ensure optimum performance.

Install the drain hose properly for smooth drainage of condensed water.

Make sure to check for and rectify any refrigerant leaks after you install or repair the unit.

This appliance uses R32 (difluoromethane) refrigerant, which is a flammable gas class 2.2 according to AS/NZS 1677 and must be handled by a refrigeration mechanic with appropriate Australian refrigerant handling licence.



**WARNING**

Risk of fire / flammable material. If the refrigerant is leaked, together with an external ignition source, there is a possibility of ignition.



**CAUTION**

Read the OPERATING INSTRUCTIONS carefully before operation.



**CAUTION**

Service personnel are required to carefully read the OPERATING INSTRUCTIONS and INSTALLATION MANUAL before operation.



**CAUTION**

Further information is available in the OPERATING INSTRUCTIONS, INSTALLATION MANUAL, and the like.

Certain levels of refrigerant require minimum room sizes. Please ensure that these minimum room sizes are adhered to for standard installations (up to 10m pipe length). If larger refrigerant charges than standard are used then please consult AS/NZS 60335.2.40 to determine the safe minimum floor area for the installation.

Make sure that the area has been made safe by having suitable ventilation and is free from ignition sources before charging or releasing the charge of R32.

Model	HSNRVX25	HSNRVX35	HSNRVX50	HSNRVX70
Standard Charge (g)	500	500	1030	1300
Minimum Floor Area (m <sup>2</sup> )	1.00	1.00	1.00	1.62



## OPERATION

**DO NOT** let the air conditioner run for extended periods when the humidity is very high or when doors or windows are left open. As this may result in an excessive operational loading and lead to product failure.

**DO NOT** cover or place articles on any part of this appliance.

**DO NOT** touch, operate or clean the air conditioner with wet hands. It may result in electric shock or product failure.

**DO NOT** insert hands or other objects through the air inlet or outlet while the appliance is operating. It may result in electric shock or product failure.

**DO NOT** place a heater or other heating appliances near this appliance, always ensure sufficient ventilation when using this appliance and a heating appliance at the same time. Failure to do so may result in product mis-operation.

Turn main power off before cleaning. Failure to do so may result in fire, electric shock, or product failure.

**DO NOT** use solvents, abrasives or harsh detergent to clean any part or surface of this appliance or spray water or allow liquids to enter the indoor unit. The enclosure of the appliance and remote control can be cleaned using a soft, damp cloth and a mild detergent.

**NEVER** touch the metal parts of the air conditioner when you remove the air filter. It may result in electric shock or product failure.

**DO NOT** leave flammable materials near the appliance. It may result in explosion or fire.

If there is excessive noise, smell or smoke coming from the appliance, turn the appliance off, isolate the power supply and contact a service agent.

**DO NOT** operate the appliance if it has been submerged into water due to flooding, contact a service agent. Failure to do so may result in electric shock, fire, serious injury, or product failure.

This appliance is not intended for use by persons (including children) with reduced physical, sensory or mental capabilities, or lack of experience and knowledge unless they have been given supervision or instruction concerning use of the appliance by a person responsible for their safety.

Children should be supervised to ensure that they **DO NOT** play with the appliance.

The air conditioning system is designed to achieve consumer comfort. It is **NOT** designed for commercial applications requiring a controlled atmosphere (i.e. computer rooms, food preservation, etc.)

**DO NOT** block the inlet or outlet of air flow. It may result product in failure.

**DO NOT** drink the condensate water drained from the appliance. This condensate is not potable and may present a health risk if consumed.

**DO NOT** expose people, animals or plants directly to the cold or hot discharge of the appliance. It may result in serious injury.

**DO NOT** mix the batteries for the remote control with other types of batteries or mix new batteries with used batteries. Failure to do so may result in product failure. **STOP** using the remote control if there is a battery fluid leak.

**OPERATING RANGE**

- Operating the unit beyond the specified temperature range may negatively impact its performance. When the outdoor temperature is too high, the air conditioner may trip the circuit breaker causing the air conditioner to shut down. When the outdoor temperature is too low, the outdoor heat exchanger may generate excessive moisture, leading to water dripping from the unit.
- In long-term cooling or dehumidification with a relative humidity of above 80%, doors and windows should be closed to prevent the indoor unit from generating too much water and causing leaks.

**Operation Range Limitations**

The table below indicates the temperature ranges the air conditioner can be operated within.

MODE	Cool Mode	Heat Mode	Dry Mode
Room Temperature	> 16°C	< 32°C	> 16°C
Outdoor Temperature	-15°C ~ 52°C	-15°C ~ 24°C	-15°C ~ 52°C

**Heating**

- The fan of the indoor unit will not start immediately when the heating cycle has started. The unit will warm up and then start blowing air to avoid blowing out cool air.
- When it is cold and wet outside, the outdoor unit will develop frost over the heat exchanger which over time will cause the system to start the defrost function.
- During defrost, the air conditioner will stop heating for about 5-12 minutes. During the defrost cycle, vapour discharge from the outdoor unit is a normal part of operation.
- Heating will automatically resume upon completion of the defrost cycle.

**Turning Off**

- When the air conditioner is turned off, the main controller will automatically decide whether to stop immediately or after running for a few seconds with lower frequency and lower air speed.

**OPERATING THE AIR CONDITIONER WITHOUT THE REMOTE CONTROL**

- You can use the Manual ON/OFF (Auto) button of the indoor unit to operate the air conditioner when the remote control is unavailable.

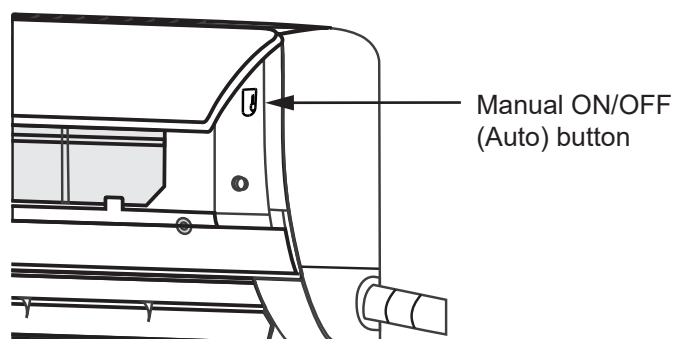

# INSTALLATION GENERAL

## CONTENTS CHECKLIST

Item and quantity provided							
Indoor unit	x1	Indoor unit support bracket	x1	Drain pipe	x1	Putty	x1
Remote controller	x1	Outdoor unit	x1	Brass nut (small)	x2	Operation manual	x1
Remote control wall bracket	x1	Rubber vibration damper	x4	Brass nut (large)	x2	Installation manual	x1
AAA battery	x2	Drain plug	x1	Tape	x1	Energy label	x1

## APPLIANCE COMPONENTS

- Indoor unit air inlet
- Filter (located behind front access panel)
- Manual ON/OFF (Auto) override button (located behind front access panel)
- Indoor unit air outlet (with louvres and vanes for setting air flow direction)
- Remote control
- Signal receiver window and temperature display (the display is built into the front access panel)
- Refrigerant pipes, electrical cable(s) (covered with binding tape)
- Condensate drain hose (covered with binding tape)
- Refrigerant entry (for service and installer use only)
- Outdoor unit air inlet (on rear & left side of unit)
- Outdoor unit air discharge and protective grille (on front of unit)

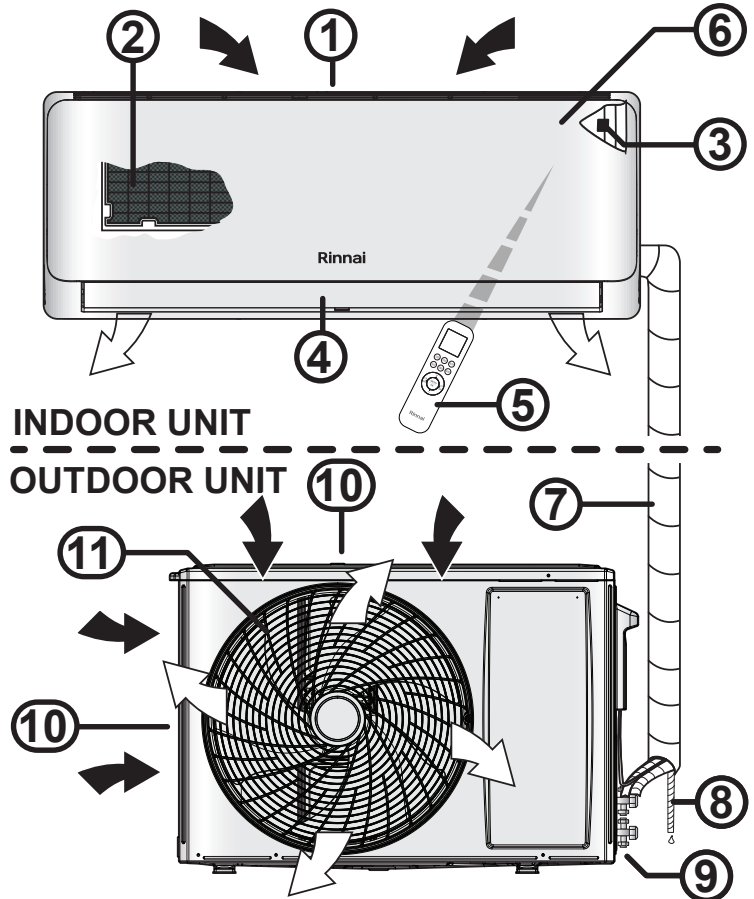

## WEIGHTS & DIMENSIONS

Model		HSNRVX25			HSNRVX35			HSNRVX50			HSNRVX70		
Weight (kg)	Indoor	7.5			7.5			11			13		
	Outdoor	24			24			28			41		
Dimensions (mm)	Indoor	A	B	C	A	B	C	A	B	C	A	B	C
		750	200	285	750	200	285	900	225	310	1082	233	330
	Outdoor	D	E	F	D	E	F	D	E	F	D	E	F
		709	77	536	709	77	536	785	77	555	900	66	700
		G	H	I	G	H	I	G	H	I	G	H	I
		309	480	280	309	480	280	353	546	300	388	632	350

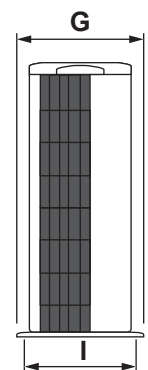
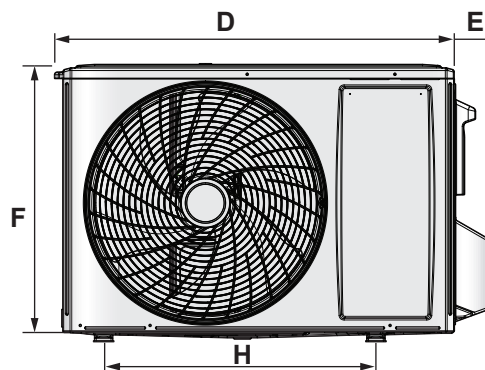
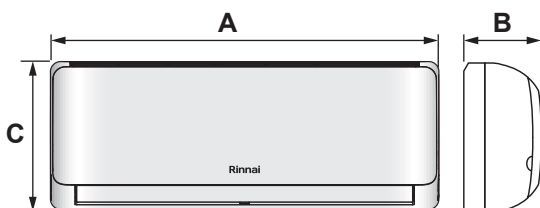

## INSTALLATION DIAGRAM - INDOOR / OUTDOOR PARTS

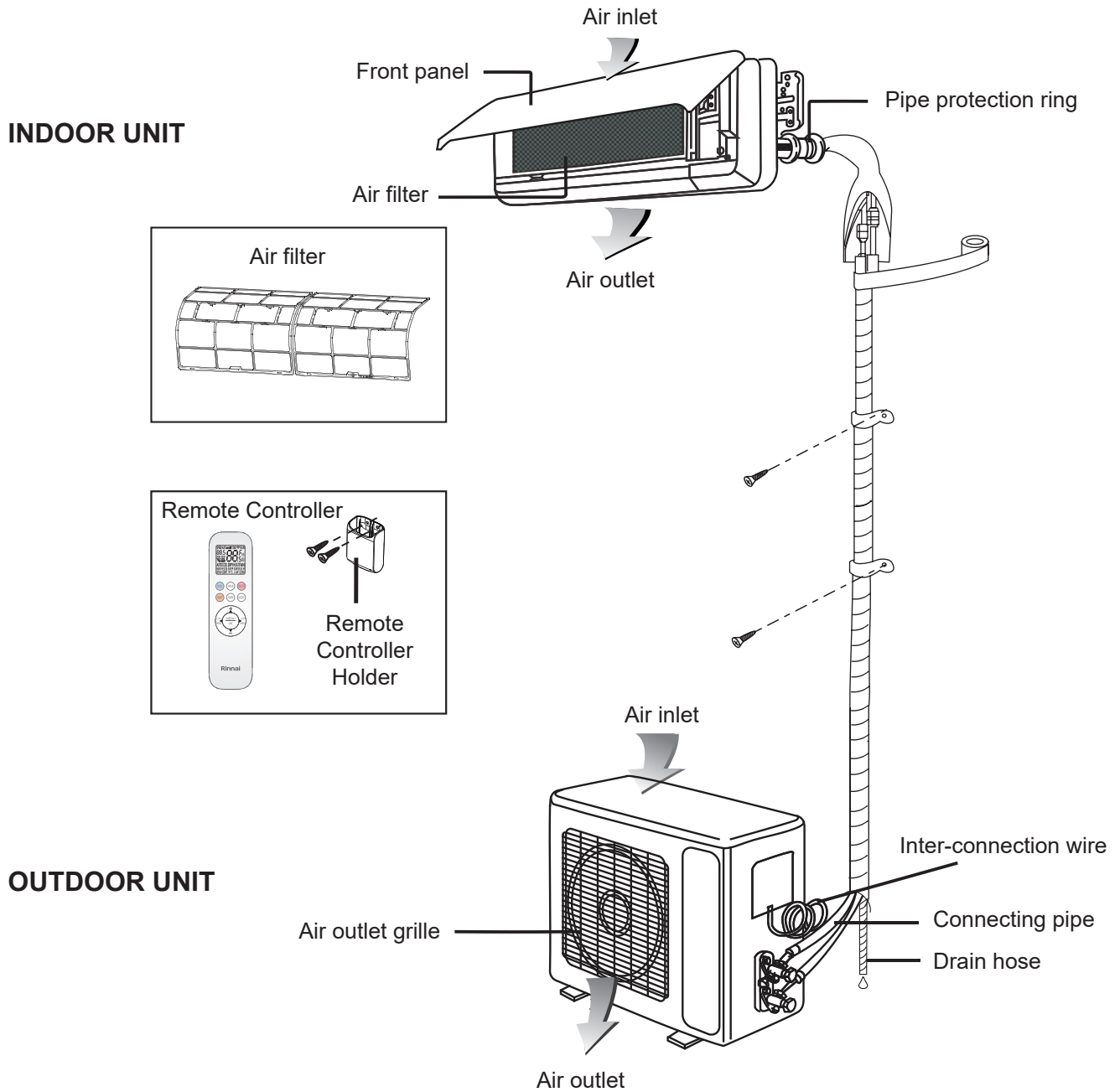

# LOCATION

## INDOOR UNIT

- Ensure the indoor unit is located away from heat or steam.
- Ensure the indoor unit is located so it can be accessed for service and replacement.
- Ensure the indoor unit is located so condensate can be drained away.
- Select a location where the indoor unit can be securely mounted.
- The clearances shown **MUST BE** maintained.

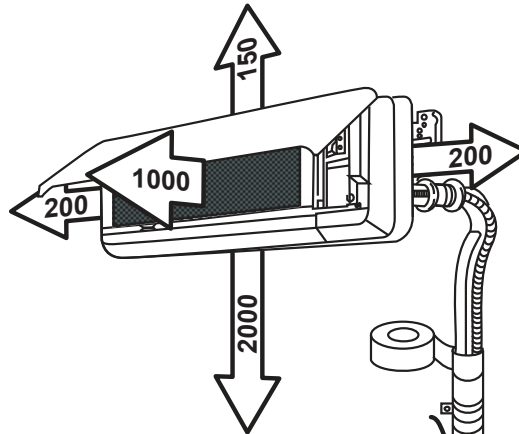

(All dimensions in mm)

## OUTDOOR UNIT

- Select the location where exposure to direct sunlight and strong wind are minimised.
- Select the location where the outdoor unit can be securely mounted.
- Select the location where the noise and air flow will not cause nuisance.
- Ensure there are no obstructions in the air flow path.
- Ensure the outdoor unit is located so it can be accessed for service and replacement.
- Do not place animals and plants near the air discharge.
- The clearances shown **MUST BE** maintained.

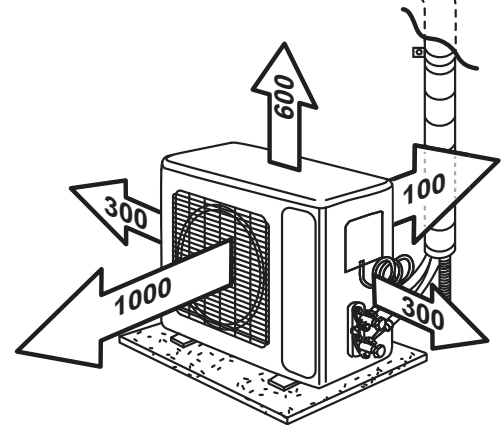

## PIPE LENGTH & ELEVATION LIMITS

Models	Pipe Size Gas		Pipe Size Liquid		Chargeless Length m	Minimum Length - X m	Maximum Length - X m	Maximum Height - Y m	Additional Refrigerant g/m
	mm	inch	mm	inch					
HSNRVX25	Ø9.52	3/8	Ø6.35	1/4	10	2	20	12	16
HSNRVX35	Ø9.52	3/8	Ø6.35	1/4	10	2	20	12	16
HSNRVX50	Ø12.7	1/2	Ø6.35	1/4	10	2	30	20	24
HSNRVX70	Ø15.88	5/8	Ø6.35	1/4	10	2	30	20	24



The outdoor unit is supplied already charged for interconnecting pipe lengths of 2 metres up to 10 metres in length.

Removal of refrigerant is necessary if pipe length is less than 2 metres and additional refrigerant will be required for pipe lengths in excess of 10 metres. (Please refer to the above table.) Removal or addition of refrigerant must be by best practice.

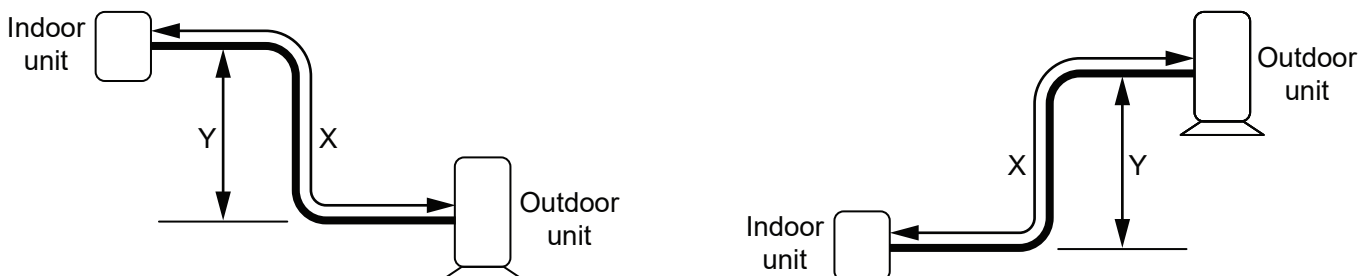

# INSTALLATION

## INDOOR UNIT INSTALLATION

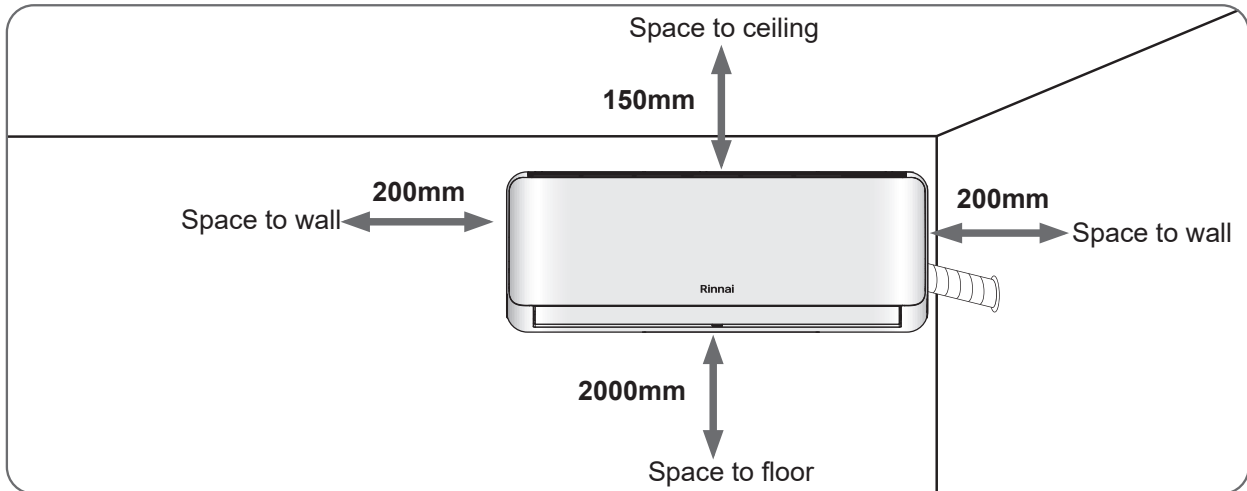

### Wall Mounting Plate

1. The wall or structure on which the units are to be mounted must be capable of supporting the weight of the appliance and the associated pipe-work.
2. Fix the mounting plate on to the wall using suitable screws, ensuring that it is both level and firmly mounted.
3. Refer to figure and tables below for installation dimensions



DO NOT install the unit in a place where electrical wiring or conduits are located.

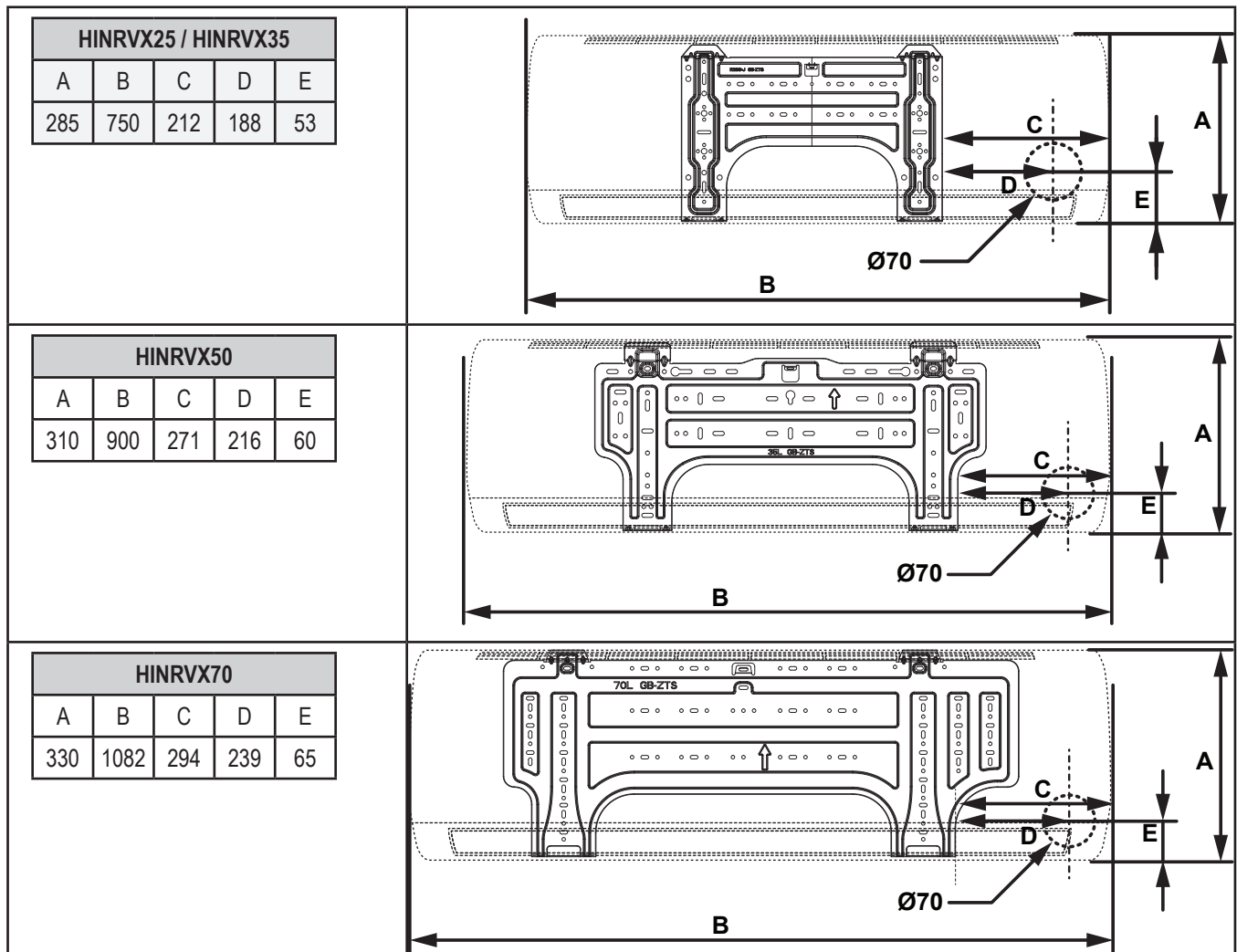

## INSTALLATION

### Wall Penetration

Drill a  $\text{Ø}60\text{-}80\text{mm}$  wall penetration through the wall with a  $2^\circ$  to  $4^\circ$  fall to the outside wall.

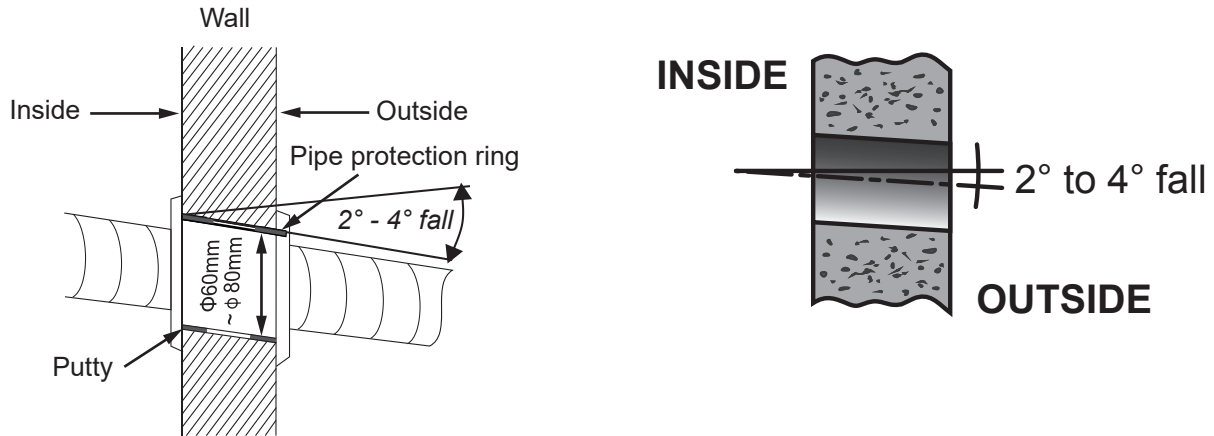

### Refrigerant Pipe Connection

1. The refrigerant piping can be routed out of the indoor unit a number of ways. For left, right, or bottom routing, use the cut-out holes on the casing of the unit. Bend the pipes carefully to the required position in order to align it with the hole.
2. For back routing, be sure to drill the hole in the proper place according to the mounting bracket.

#### Right side, right back or right bottom piping

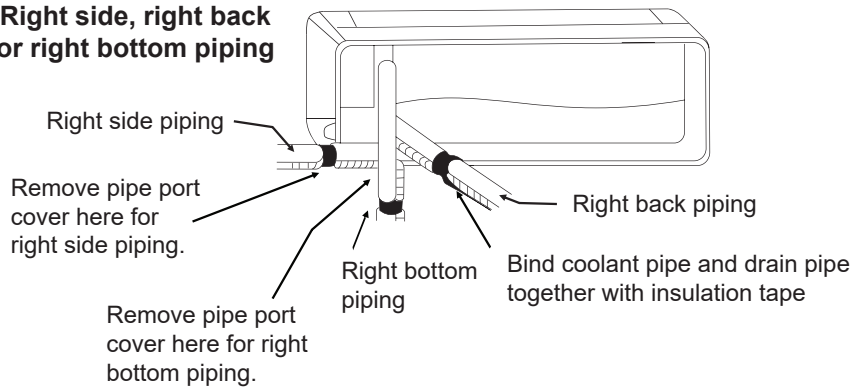

#### Left side, left back or left bottom piping

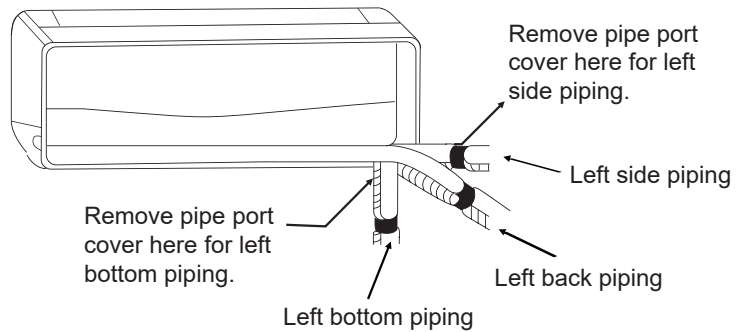

**Indoor Unit Electrical Connections**



Must be installed, maintained and removed by authorised persons in accordance with AS/NZS 3000 and all other relevant local regulations and municipal building codes including OH&S requirements.

Ensure electric wiring is installed properly. Improper installation may cause malfunction, fire, or electric shock.

The unit must be earthed following local electrical codes.

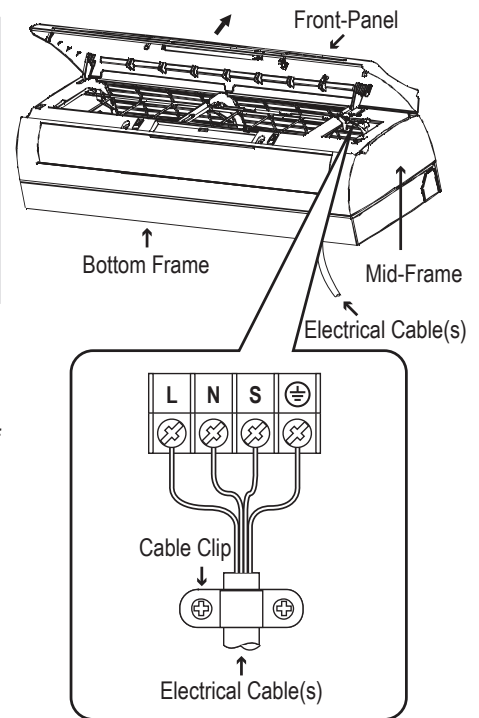

1. Open the front panel.
2. Remove the wiring cover.
3. Insert the electrical cable(s) through the bottom side at the back of indoor unit.
4. Secure the cable onto the control board with the cable clip.
5. Connect the cables as shown on the drawing to the corresponding terminals.
6. Re-install the wiring cover.
7. Close the front panel.

**Mounting the Indoor Unit (Wall Installation)**

1. Position the piping as shown on the drawing.
2. Tape the refrigerant pipes, electric cable(s) and drain hose. Ensure the water drain hose is located at the lowest side of the bundle.

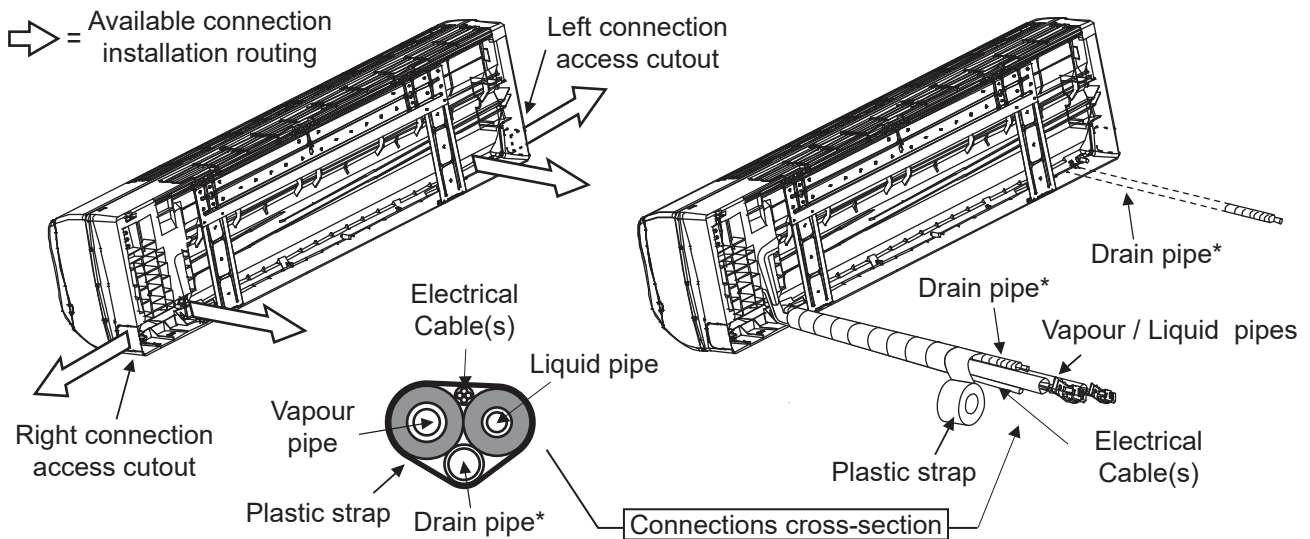

\* The drain pipe is dual handed and may be installed to either the left or right of the appliance.

1. To use this option unclasp the drain hose.
2. Unscrew the rubber plug from the alternate drainage discharge connection point.
3. Clip the drainage hose into the alternate discharge connection point.
4. Screw the rubber plug into the unused drainage discharge connection point.

## INSTALLATION

- Hang the mounting slots of the indoor unit on the upper portion of the mounting plate. Ensure that the hooks are properly seated on the plate.
- Push the unit towards to the wall, and hook the unit onto the lower fixing hook.

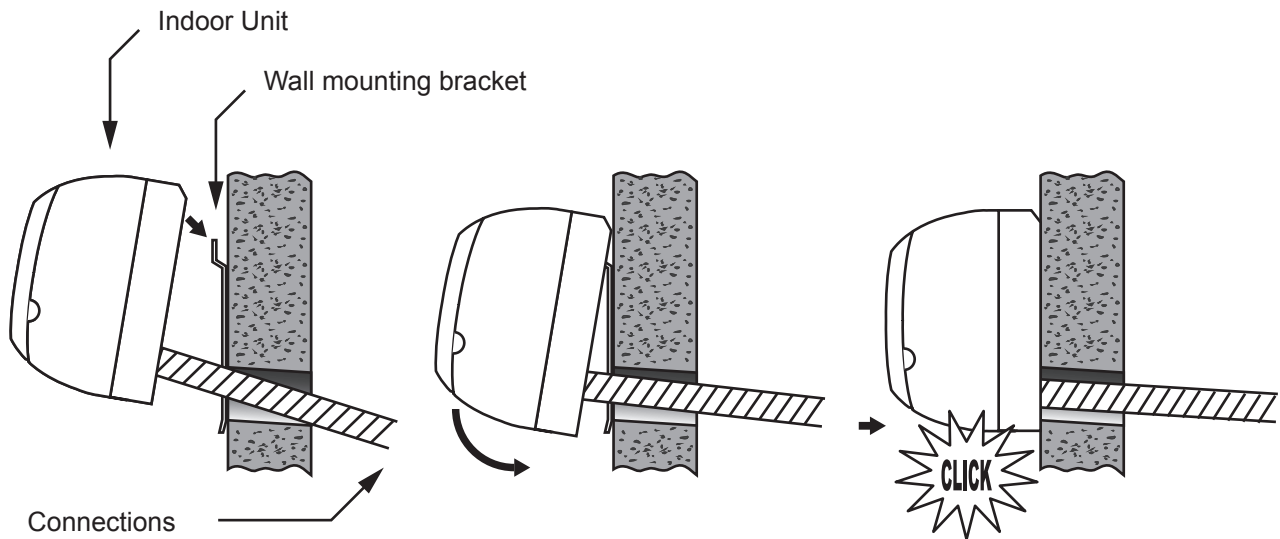

Ensure that there is no leakage from the drain pipe connection and that the drain pipe has a continuous fall to the outside.

Ensure that all wall penetrations are sufficiently weatherproofed.

### Water Drainage Piping

The indoor drain pipe must be in a downward gradient for smooth drainage. Avoid situations that are likely to cause water to leak.

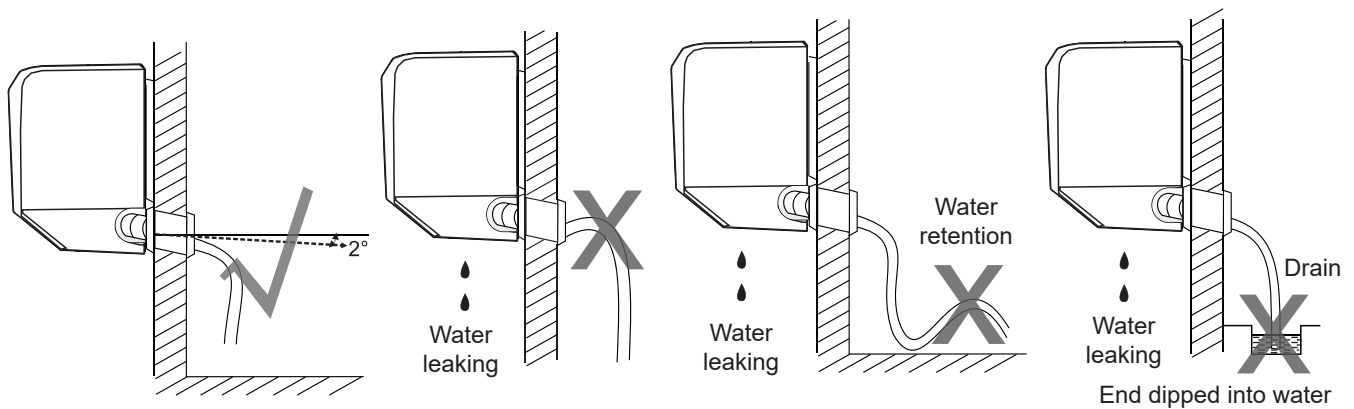

- Connect the drain pipe to the drain hose outlet of the indoor unit,
- Bind the joint with PVC insulation tape (not supplied).

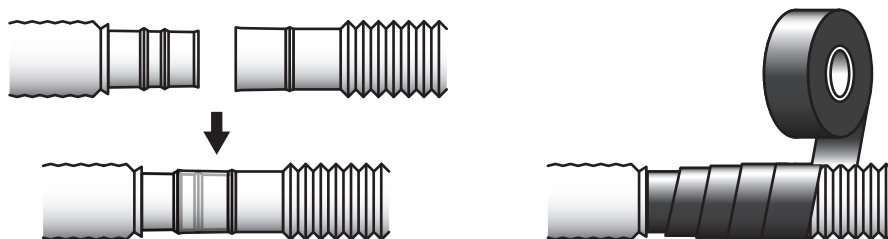

**REFRIGERANT PIPES**

**Flaring**



- The main cause for refrigerant leakage is due to defects with the flaring work.
- The installer must ensure that all piping used complies with both:  
AS/NZS 1571:1995 - Copper - Seamless tubes for air conditioning and refrigeration.  
AS/NZS 4041:2006 - Pressure piping.
- All pipework and fittings should be thoroughly examined for cleanliness and suitability for the system and refrigerant prior to assembling.
- All unsealed tubing must be thoroughly inspected and, if necessary, cleaned before assembly to remove any copper residue and/or scale particles such as dirt or metal.
- Metal filings must not be left in pipework after cutting as they can cause damage compressor (i.e. shaft seals, bearings, etc.).
- Prior to assembly, refrigeration pipes must be clean and burr free. They must not be crushed or kinked.
- For flare connections, a suitable lubricant must be used between the back of the flare and the nut to avoid tearing the flare when tightening the nut.

**Piping Works & Flaring Technique**

Do not use contaminated or damaged copper tubing. If the evaporator, condenser, or any piping has been exposed to the atmosphere for 15 seconds or more, the system must be vacuumed. Do not remove plastic plugs or brass nuts from piping connections until the connections are ready to be made.

If any brazing work is required, ensure that a nitrogen gas purge is utilised to prevent soot formation on the inside wall of copper tubing.

Cut the pipe as straight as possible (Technique 1 below). Make sure to use a deburring tool to remove any burrs. Hold the pipe with opening facing down to prevent metal chips from entering the pipe (Technique 2 below).

*Technique 1*

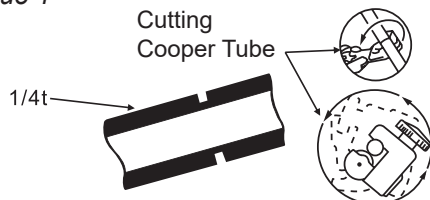

*Technique 2*

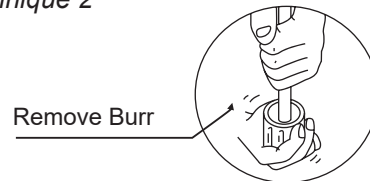

**Install Refrigerant Piping**

- This will avoid unevenness on the flare faces which will cause gas leak.
- Insert the flare nuts, mounted on the connection parts of both the indoor unit and outdoor unit, into the copper pipes.
- The exact length of pipe protruding from the top surface of the swaging block is determined by the flaring tool. See Figure below.
- Fix the pipe firmly on the swaging block. Match the centre of both the swaging block and the flaring punch, then tighten the flaring punch fully.
- The refrigerant pipe connection are insulated by closed cell polyurethane.

Ø Tube, D	A (mm)	
	Imperial (Wing-nut Type)	Rigid (Clutch Type)
6.35	1.3	0.7
9.52	1.6	1.0
12.70	1.9	1.3
15.88	2.2	1.7
19.05	2.5	2.0

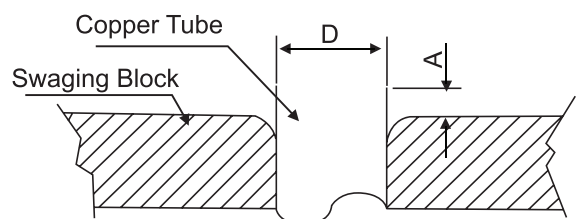

## INSTALLATION

### Install the Connection Pipe

- Apply a slight amount of POE oil to the inside of the flare to prevent binding.
- Align the centre of the piping and tighten the flare nut sufficiently with fingers. See Figure below.
- Adjust the torque wrench to the proper torque settings according to the table. Finally, tighten the flare nut with torque wrench until the wrench clicks. When tightening the flare nut with the torque wrench, ensure that the tightening direction follows the arrow indicated on the wrench.

Pipe Dimensions (Ø)		Torque Wrench Setting (Nm)
Metric (mm)	Imperial (inch)	
6.35 mm	1/4"	18 Nm
9.52 mm	3/8"	42 Nm
12.7 mm	1/2"	55 Nm
15.88 mm	5/8"	75 Nm

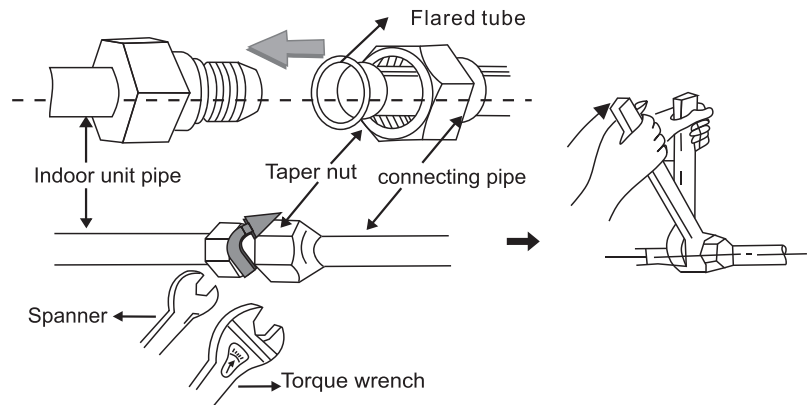

**OUTDOOR UNIT INSTALLATION**

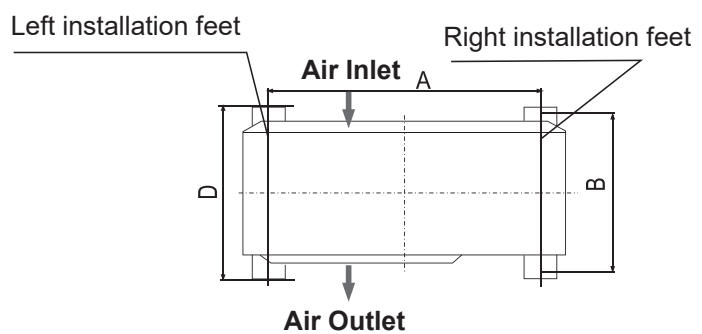
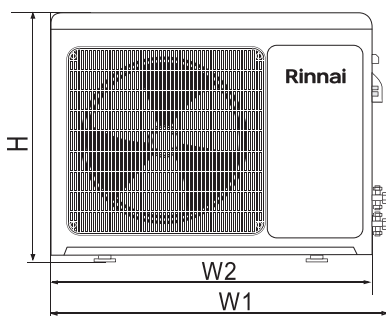
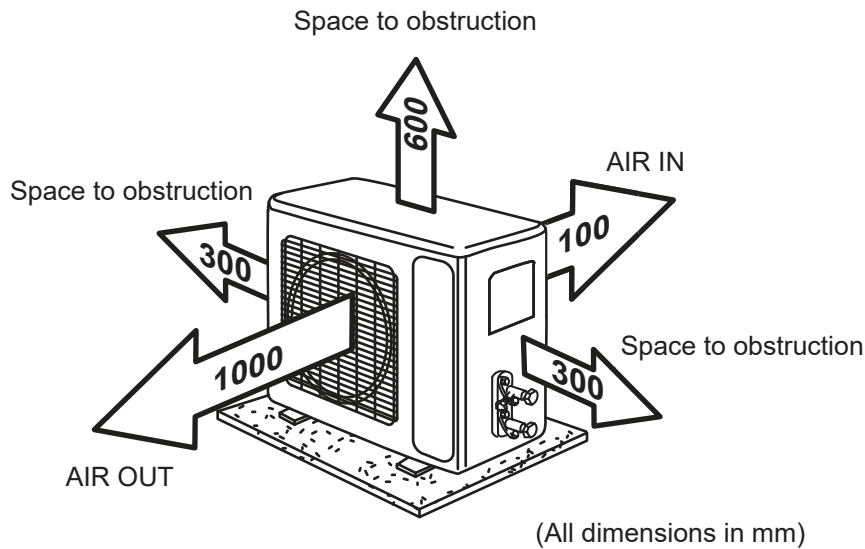

Installation Outdoor Unit W1 (W2) *H *D [mm]	
Unit	Dimensions
HONRVX25	761(705) *536 *309
HONRVX35	761(705) *536 *309
HONRVX50	838(785) *555 *353
HONRVX70	954(900) *700 *388

Bolt Distance	
(A) mm	(B) mm
480	280
480	280
546	300
632	350

**Outdoor Installation Location**

- Select the location where exposure to direct sunlight and strong wind are minimised.
- Select the location where the outdoor unit can be securely mounted.
- Select the location where the noise and air flow will not cause nuisance.
- Ensure there are no obstructions in the air flow path.
- Ensure the outdoor unit is located so it can be accessed for service and replacement.
- Do not place animals and plants near the air discharge.

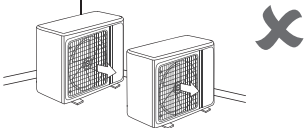
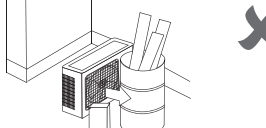
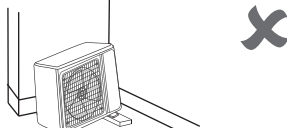
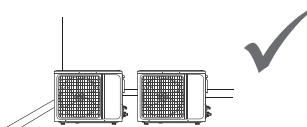
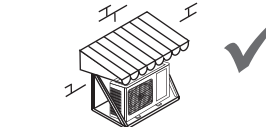
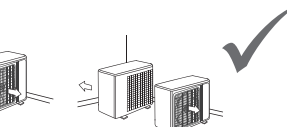
<p><b>Incorrect Installation</b></p>			
<p><b>Correct Installation</b></p>			

**Coastal Installation (Outdoor unit)**

1. The windbreak should be strong enough like concrete to prevent the sea wind from hitting the unit. The height and width should be more than 150% of the outdoor unit.
2. Select a well-drained place. Install the outdoor unit on the opposite side of the direction of the sea wind, or set up a windbreak to avoid exposed to the sea wind. Seaside applications will require more frequent maintenance checks and cleaning. Be sure to keep the system free of salt build up by washing the unit with clean water at low pressure.
3. The unit should be kept more than 70cm from the windbreak for easy air flow.

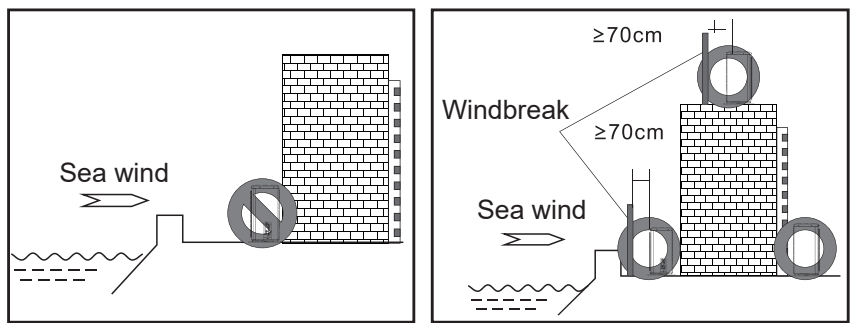

**Outdoor Unit Electrical Connections**



**Must be installed, maintained and removed by authorised persons in accordance with AS/NZS 3000 and to all other relevant local regulations and municipal building codes including OH&S requirements.**

**Ensure electric wiring is installed properly. Improper installation may cause malfunction, fire, or electric shock.**

**The unit must be earthed following local electrical codes.**

1. Remove the wiring cover.
2. Secure the electrical cable(s) and power cable onto the control board with the cable clip.

3. Connect the cables as shown on the drawing below.

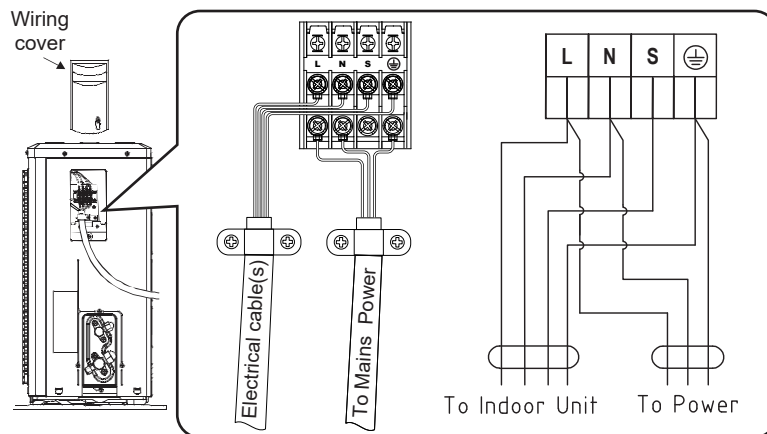

4. Re-install the wiring cover.

**DRED Connection (optional)**

This appliance is supplied with an DRED interface, the interface provides two connection methods of either a four wire terminal connection or an RJ45 socket.



**Must be installed, maintained and removed by authorised persons in accordance with AS/NZS 3000 and to all other relevant local regulations and municipal building codes including OH&S requirements.**

**Ensure electric wiring is installed properly. Improper installation may cause malfunction, fire, or electric shock.**

1. Remove the wiring cover.
2. Connect the power feed to the terminal block as shown on the drawing below.
3. Connect the communication cable to DRED interface using either the four wire terminal connections or RJ45 socket provided.
4. Re-install the wiring cover.

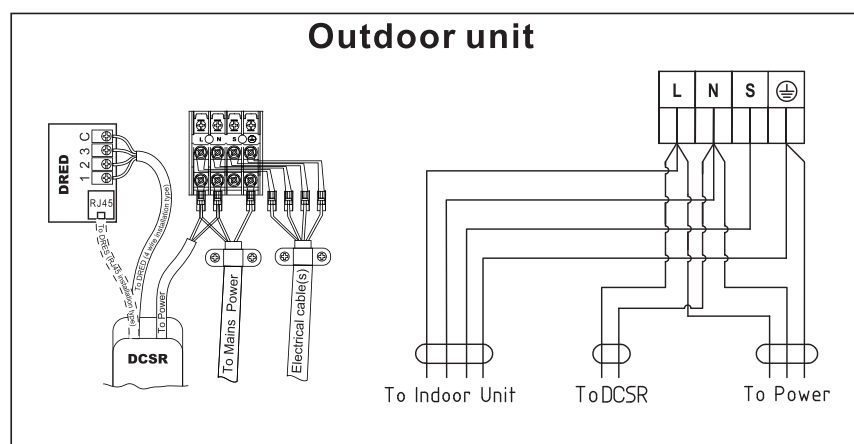
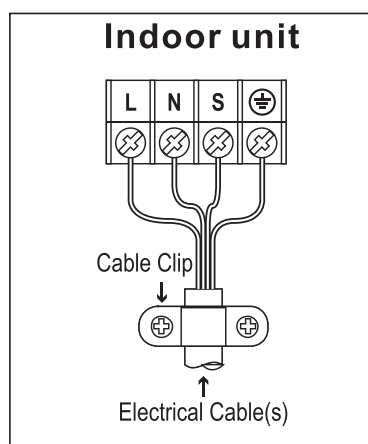

**OUTDOOR CONDENSATE DRAINAGE**

- A condensate drainage point is provided in the base of the outdoor unit.
- A drainage hose (installer to supply) will need to be fitted.

When the unit is in heating mode, the outdoor unit can generate water that will drip from the bottom of the unit. To control the flow of that water, please use the drain elbow supplied.

1. Install the drain elbow in the Ø25mm hole on the bottom of the base plate, and connect the drain hose to the elbow. Route the hose to a location so that the water formed in the outdoor unit can be drained out to a proper location.
2. In cold areas, do not use a the drain elbow or drain plugs on the outdoor unit. Plugging the holes will cause ice to build-up in the base pan which could result in damage to the unit. In cold climates, make sure the unit has plenty of space to drain and avoid snow drifts.



**Drainage of the condensate must conform with all local regulations and municipal building codes including local OH&S requirements.**

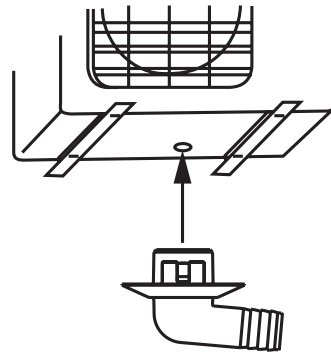

**INSTALLING REFRIGERANT PIPE CONNECTION**

Additional refrigerant may be required based on the length of the refrigerant pipe to ensure proper performance and prevent damage to the unit. The chart below shows the requirements of refrigerant needed based on the piping length.

Models	Chargeless (Length)	Maximum (Length)	Maximum (Height)	Additional Refrigerant
Unit	m	m	m	g/m
HONRVX25	10	20	12	16
HONRVX35	10	20	12	16
HONRVX50	10	30	20	24
HONRVX70	10	30	20	24

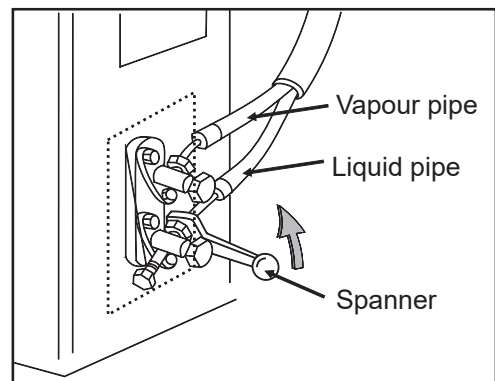
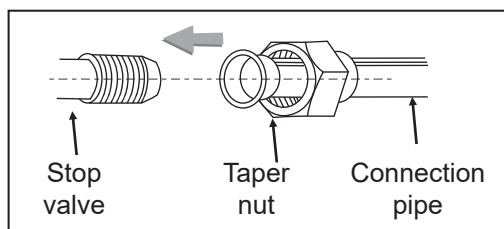

**To prevent heat loss and wet floors due to dripping of condensation, both pipes must be properly insulated.**

**Ensure the joint nut is tightened firmly to avoid leakage.**

**Ensure that both the connections and the refrigerant pipes are wrapped with insulation material.**

**AIR PURGING & LEAKAGE TEST**



**DO NOT** mix any substance other than the specified refrigerant (R32) into refrigerant system.

When refrigerant gas leaks occur, ventilate the room immediately.

R32, as well as other refrigerants, should always be recovered and never be released directly into the environment.

Use a vacuum pump for R32 exclusively. Using the same vacuum pump for different refrigerants may damage the vacuum pump or the unit.



It is necessary to purge air and check for gas leakage after piping work is completed.

If using additional refrigerant, perform air purging from the refrigerant pipes and indoor unit using a vacuum pump, then charge additional refrigerant.

Use a hex socket (3/16") to operate the service valves.

All refrigerant pipe joints to be tightened with a torque wrench at the specified torque.

**Evacuation Vacuum Method / Leak Test**

1. Remove the caps from the vapour valve, vapour valve service port and the liquid valve.
2. Connect charge hose from the low pressure gauge (manifold gauge set) to the vapour valve service port.
3. Open the low pressure gauge valve (manifold gauge set), turn on the vacuum pump and run for a minimum of 15 minutes.
4. Close low pressure gauge valve (manifold gauge set) and turn off vacuum pump.
5. Wait 2 minutes to allow pressure to stabilise, then check that the low pressure gauge is maintaining a pressure of -100 kPa (-76 cmHg).
6. Disconnect charge hose from the vapour valve service port and replace the vapour valve service port cap.
7. Open both the vapour and the liquid valves to charge the refrigerant system for test running.
8. Test run the system through both heating and cooling cycles and test for leaks.
9. Replace the vapour and liquid valve caps.

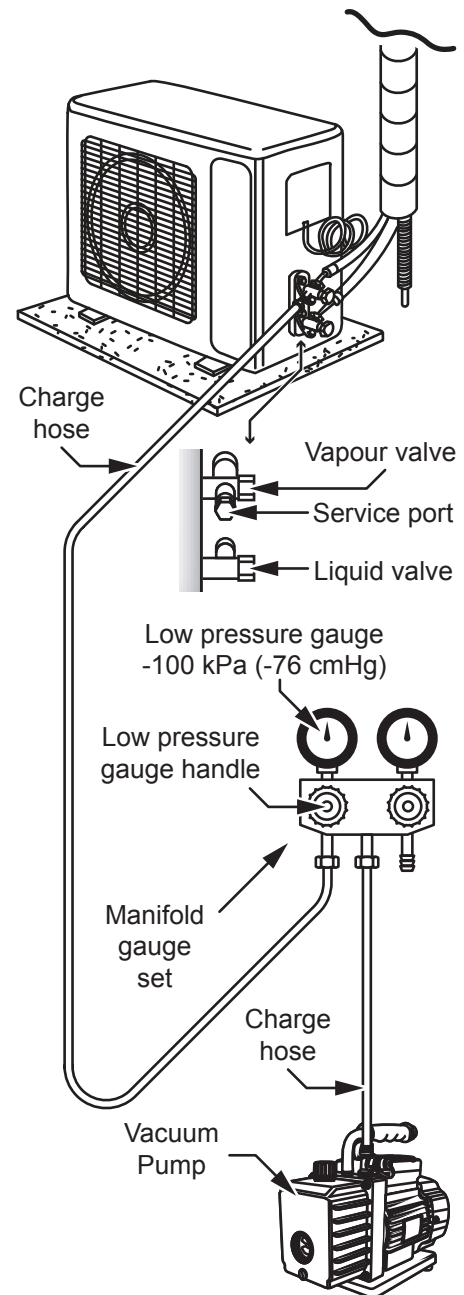

**Both the vapour and liquid valve caps MUST BE on tight.**

10. The system is now ready to run.

**Adding Refrigerant for Longer Line Length**

Additional refrigerant for longer piping runs can be added either at the time of evacuation of the new installation or whilst the unit is operating, see "Pipe Length & Elevation Limits" on page 12.



It is very easy to overcharge, take caution in charging refrigerant liquid and keep your eye on the scales to avoid overcharging the unit.

Take care not to discharge refrigerant into the atmosphere during installation, re-installation, repair or service.

**FINAL CHECKLIST**



The checklist is **ONLY** to be completed by an Authorised Person.

Check Item	✓	What can happen if not checked
Is the indoor unit installed securely?	<input type="checkbox"/>	Falling, vibration, noise
Has an inspection been made to check for gas leakage?	<input type="checkbox"/>	No cooling or heating
Has all thermal insulation been completed (vapour pipes, liquid pipes, indoor portions of the drain hose extension)?	<input type="checkbox"/>	Condensation
Is the drainage secure?	<input type="checkbox"/>	Water leakage
Are the electric wires installed correctly?	<input type="checkbox"/>	No cooling or heating, may cause electrical shock or electrical fire.
Is the wiring in accordance within the specifications?	<input type="checkbox"/>	Operation failure, electrical fire
Are all inlets / outlets of the indoor and outdoor units free of any obstructions?	<input type="checkbox"/>	No cooling or heating
Are the stop valves open?	<input type="checkbox"/>	No cooling or heating
Are the pipes designed for use with R32?	<input type="checkbox"/>	Pipe or pipe connection leakage
Has a leak test been carried out for the pipe connections?	<input type="checkbox"/>	Pipe connection leakage
Has air purging been carried out?	<input type="checkbox"/>	No cooling or heating
Has the appliance been tested for correct operation?	<input type="checkbox"/>	No cooling or heating
Is the end user fully aware of the operating procedure?	<input type="checkbox"/>	Incorrect operation

**If you have answered no to any of the above, you must check and correct before appliance hand-over to customer.**

# SPECIFICATIONS

RINNAI - VX Series Hi-Wall Split System		HSNRVX25	HSNRVX35	
Nominal Capacity	kW	2.6	3.5	
Power Supply to Outdoor Unit	V - Ph - Hz	220-240 - 1 - 50		
Maximum Input Power (Cooling / Heating)	W	1500	1600	
Maximum Input Current (Cooling / Heating)	A	7.5	8.0	
Connectivity	-	Wi-Fi Enabled		
Demand Response Enabling Device	-	DRED Enabled		
Cooling	Rated Capacity	kW	2.64	3.5
	Capacity Range		0.3-4.0	0.8-4.1
	Rated Power Input	W	670	940
	Rated Current (Range)	A	3.5 (1.4-7)	4.8 (0.7-8.0)
	AEER	W/W	3.911	3.694
	Star Rating (Hot / Average / Cold)	-	6.5/5/5.5 STAR	5/4.5/5 STAR
Heating	Rated Capacity	kW	2.9	4.0
	Capacity Range		0.3-4.2	0.8-4.5
	Rated Power Input	W	670	1080
	Rated Current	A	3.5 (1.4-7)	5.0 (0.7-8.0)
	ACOP	W/W	4.296	3.678
	Star Rating (Hot / Average / Cold)	-	3.5/3/2.5 STAR	3.5/2.5/1.5 STAR
Suitable Area Coverage (up to 2.6m insulated ceiling)	m <sup>2</sup>	13-17	18-24	
Indoor Unit Model No.		HINRVX25	HINRVX35	
Air Flow (Turbo / Hi / Med / Lo)	L/s	Cooling 156/139/128/119 Heating 181/167/147/139	Cooling 167/147/132/117 Heating 167/153/133/117	
Moisture Removal	L/h	0.5	1.0	
Air Flow (Turbo / Hi / Med / Lo)	m <sup>3</sup> /h	Cooling 560/500/460/430 Heating 650/600/530/500	Cooling 600/530/475/420 Heating 600/550/480/420	
Sound Power Level	dB(A)	50	51	
Sound Pressure Level @ 1m (Turbo / Hi / Med)	dB(A)	42 / 39 / 35 / 31	43 / 41 / 38 / 34	
Air Swing Louvres Type	Direction	4D		
Dimensions	Dimension (W x H x D)	mm	750×285×200	750×285×200
	Packing (W x H x D)		806×346×267	806×346×267
	Net / Gross Weight	kg	7.5/9	7.5/9
Operating Range	Cooling	°C	16	
	Heating		32	
Outdoor Unit Model No.		HONRVX25	HONRVX35	
Sound Power Level	dB(A)	60	60	
Sound Pressure Level @ 1m		49	50	
Dimensions	Dimension (W x H x D)	mm	705×279×530	705×279×530
	Packing (W x H x D)		825×595×326	825×595×326
	Net / Gross Weight	kg	24/27	24/27
Refrigerant	Type		R32	
	Charged Volume	kg	0.50	0.50
	Pipe Size: Liquid / Gas	mm	6.35/9.52	6.35/9.52
	Maximum Pipe Length	m	20	20
	Chargeless Length		10	10
	Extra Charge for Lengths >10m	g/m	16	16
	Maximum Vertical Separation	m	12	12
Ambient Temperature Limits	Cooling	°C	-15 ~ 52	
	Heating		-15~24	

Capacities tested in accordance with AS/NZS 3823.2, with 5m interconnecting pipe length. With our policy of continuous improvement, we reserve the right to change, or discontinue at any time, specifications or designs without notice.

## SPECIFICATIONS

RINNAI - VX Series Hi-Wall Split System			HSNRVX50	HSNRVX70
Nominal Capacity		kW	5.2	7.0
Power Supply to Outdoor Unit		V - Ph - Hz	220~240 - 1 - 50	
Maximum Input Power (Cooling / Heating)		W	2400	3400
Maximum Input Current (Cooling / Heating)		A	12	16
Connectivity		-	Wi-Fi Enabled	
Demand Response Enabling Device		-	DRED Enabled	
Cooling	Rated Capacity	kW	5.3	7.0
	Capacity Range		1.3-5.8	1.8-7.4
	Rated Power Input	W	1630	2150
	Rated Current	A	7.4 (2.2-9.5)	9.5 (1.5-11.5)
	AEER	W/W	3.239	3.262
	Star Rating (Hot / Average / Cold)	-	4/3.5/4 STAR	3.5/3.5/3.5 STAR
Heating	Rated Capacity	kW	5.3	8.20
	Capacity Range		1.3-6.0	1.8-8.3
	Rated Power Input	W	1560	2450
	Rated Current	A	7.2 (2.0-8.2)	11 (1.5-12.5)
	ACOP	W/W	3.384	3.336
	Star Rating (Hot / Average / Cold)	-	3.5/2.5/2 STAR	3/2/1.5 STAR
Suitable Area Coverage (up to 2.6m insulated ceiling)		m <sup>2</sup>	25-34	35-47
Indoor Unit Model No.			HINRVX50	HINRVX70
Air Flow (Turbo / Hi / Med / Lo)		L/s	Cooling 236/203/181/153 Heating 250/217/194/153	Cooling 361/333/281/242 Heating 333/286/258/242
Moisture Removal		L/h	1.6	3.0
Air Flow (Turbo / Hi / Med / Lo)		m <sup>3</sup> /h	Cooling 850/730/650/550 Heating 900/780/700/550	Cooling 1300/1200/1010/870 Heating 1200/1030/930/870
Sound Power Level		dB(A)	58	63
Sound Pressure Level @ 1m (Turbo / Hi / Med)			48 / 44 / 40 / 37	53 / 49 / 45 / 41
Air Swing Louvres Type		Direction	4D	
Dimensions	Dimension (W x H x D)	mm	900×310×225	1080×330×234
	Packing (W x H x D)		950×372×292	1135×390×302
	Net / Gross Weight	kg	11/14	13/16
Operating Range	Cooling	°C	16	
	Heating		32	
Outdoor Unit Model No.			HONRVX50	HONRVX70
Sound Power Level		dB(A)	63	63
Sound Pressure Level @ 1m			53	56
Dimensions	Dimension (W x H x D)	mm	785×300×555	900×700×350
	Packing (W x H x D)		905×615×372	1015×757×415
	Net / Gross Weight	kg	28/31	41/43
Refrigerant	Type		R32	
	Charged Volume	kg	1.03	1.30
	Pipe Size: Liquid / Gas	mm	6.35/12.70	6.35/15.88
	Maximum Pipe Length	m	30	30
	Chargeless Length		10	10
	Extra Charge for Lengths >10m	g/m	24	24
	Maximum Vertical Separation	m	20	20
Ambient Temperature Limits	Cooling	°C	-15 ~ 52	
	Heating		-15 ~ 24	

Capacities tested in accordance with AS/NZS 3823.2, with 5m interconnecting pipe length. With our policy of continuous improvement, we reserve the right to change, or discontinue at any time, specifications or designs without notice.



# Rinnai Australia Pty Ltd

ABN 74 005 138 769 | AU45204

82-88 Mills Road, Braeside, Victoria, 3195  
P.O. Box 460, Braeside, Victoria, 3195  
Tel: (03) 9271 6625

## **Customer Support**

Tel: 1300 555 545\*

*Monday to Friday, 8.00 am to 5.00 pm EST.*

*\*Cost of a local call may be higher from a mobile phone.  
(National calls from public phones in Australia are free.)*

For further information visit [www.rinnai.com.au](http://www.rinnai.com.au)  
or email [enquiry@rinnai.com.au](mailto:enquiry@rinnai.com.au)

Rinnai has a Service and Spare Parts network with personnel who are fully trained and equipped to give the best service on your Rinnai appliance. If your appliance requires service, please call Customer Support. Rinnai recommends that this appliance be serviced once a year.

With our policy of continuous improvement, we reserve the right to change, or discontinue at any time, specifications or designs without notice.