

MODELS – Rinnai Inverter Multi Split System

Outdoor	Indoor Hi-Wall	Indoor Ducted	Indoor Cassette	Indoor Console
MON2H05B1LA	HINRPX20M	DINSD26MBA	CIN020RMB	FINRP50MB
MON3H07B1LA	HINRPX26M	DINSD35MBA	CIN026RMB	
MON4H09B1LA	HINRPX35M	DINSD50MBA	CIN035RMB	
MON5H11B1LA	HINRPX50M	DINLR07B1A	CIN050RMB	
MON5H14B1LA	HINRPX60M	DINLR09B1A		
MON6H19B1TA	HINRPX70M	DINLR11B1A		
	HINRPX80M			

REFRIGERANT
R32

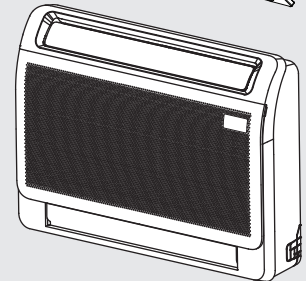
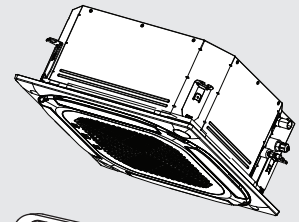
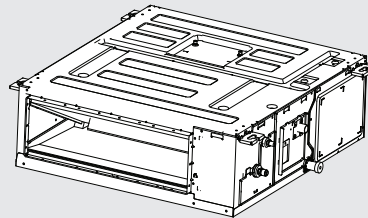
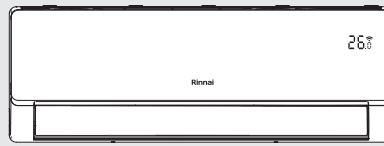
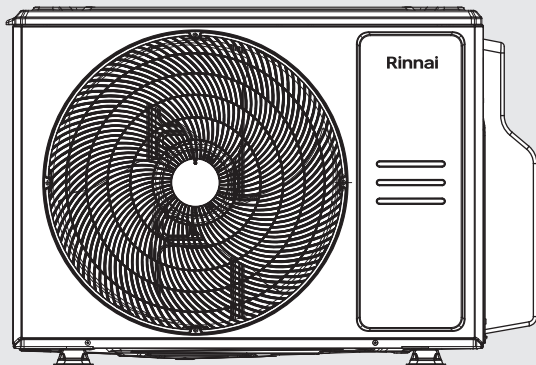

Multi Split Type Air Conditioner Installation Manual (Outdoor)

Rinnai



Read this manual and SAFETY MANUAL (if any) carefully before installing or operating your new air conditioning unit. Make sure to save this manual for future reference.

Please check the applicable models, technical data and manufacturer information from the “Operation Manual” in the packaging of the outdoor unit.

This appliance must be installed in accordance with:

- Manufacturer’s Installation Instructions
- Current AS/NZS 3000, AS/NZS 5149, AS/NZS 5141
- Local regulations, including local OH&S requirements, and Municipal Building Codes, including the National Construction Code (NCC).

This appliance must be installed, maintained and removed only by an Authorised Person. Rinnai recommends that this appliance be serviced once a year.

For continued safety of this appliance it must be installed and maintained in accordance with the manufacturer’s instructions.



The design and specifications are subject to change without prior notice for product improvement. Consult with the Dealer or manufacturer for details.

Any updates to the manual will be uploaded to the service website, please check for the latest version.



PLEASE REFER TO ANY OPERATING MANUALS AND USER OPERATING GUIDES ACCOMPANYING ANCILLARY EQUIPMENT (WHERE FITTED)

TABLE OF CONTENTS

Warnings and Important Information	4
Safety Precautions	6
Disposal Guidelines	8
Specifications	9
Installing Multiple Units	9
Technical Specifications	10
Outdoor Unit Installation	14
Outdoor Unit Accessories	14
Optional Accessories	14
Installation Summary	15
Installation Instructions – Outdoor Unit	16
Special Considerations For Extreme Weather	17
Unit Mounting Dimensions	19
Rows of Series Installation	19
Drilling Hole In Wall	19
When selecting a 7.0kW & 8.0kW Indoor Unit	20
Refrigerant Piping Connection	21
Wiring	24
Outdoor Unit Wiring	25
Outdoor Unit Wiring Diagram	27
Pressure & Leak Test	28
Dry Nitrogen Pressure Test	28
Leak Testing Instructions	28
Air Evacuation	29
Preparations and Precautions	29
Evacuation Instructions	29
Adding Refrigerant	30
Safety And Leakage Check	32
Test Run	33
Before Test Run	33
Test Run Instructions	33
Automatic Correction Function	34
Automatic Wiring/Piping Correction Function	34
Commissioning	35
Commissioning Checklist	35
Contacts	36

WARNINGS AND IMPORTANT INFORMATION



READ ALL INSTRUCTIONS BEFORE USING THE APPLIANCE

Always comply with the following precautions to avoid dangerous situations and to ensure optimum performance.

Failure to carefully read and follow all instructions in this manual can result in equipment malfunction, property damage, personal injury and/or death.

WARNINGS: WHEN IGNORED, CAN RESULT IN SERIOUS INJURY OR DEATH.

CAUTIONS: WHEN IGNORED, CAN RESULT IN MINOR INJURY OR PRODUCT DAMAGE.



REGULATORY / INSTALLATION

This appliance shall be installed in accordance with:

- Manufacturer's Installation Instructions.
- Current AS/NZS 3000, AS/NZS 5141, AS/NZS 5149, AS/NZS 3500 National Plumbing & Drainage, HB276 - A Guide to good practice for energy efficient installation.
- Local regulations, including local OH&S requirements, and Municipal Building Codes, including the National Construction Code (NCC).
- This appliance must be installed, maintained and removed by an Authorised Person.

For continued safety of this appliance it must be installed and maintained in accordance with the manufacturers instructions.

This appliance uses R32 refrigerant.

This appliance is heavy, use 2 people or mechanical lifting device. Improper lifting may result in serious injury.

Take care when opening or unpacking this appliance. Failure to do so may result in serious injury or product failure.

DO NOT modify the electrical wiring of this appliance. If the control power wiring is damaged or deteriorated then it must be replaced by an authorised person. Failure to do so may result in electric shock, fire, serious injury or product failure.

DO NOT install the air conditioner on an unstable or non level surface or where there may be a danger of it falling. It may result in death, serious injury, or product failure.

DO NOT install the outdoor unit where noise may cause nuisance.

DO NOT install the outdoor unit where it will be exposed to sea wind (salt spray) as this will reduce durability.

This appliance can be used by children aged from 8 years and above and persons with reduced physical, sensory or mental capabilities or lack of experience and knowledge if they have been given supervision or instruction concerning use of the appliance in a safe way and understand the hazards involved. Children shall not play with the appliance. Cleaning and user maintenance shall not be made by children without supervision. Refer to AS/NZS Standards and regulations.

This appliance is not intended for use by persons(including children) with reduced physical, sensory or mental capabilities, or lack of experience and knowledge, unless they have been given supervision or instruction concerning use of the appliance by a person responsible for their safety. Children should be supervised to ensure that they do not play with the appliance.



MANDATORY INSPECTION PRIOR TO INSTALLATION

Immediately report any damage or discrepancies to the Supplier of the appliance. This appliance was inspected and tested at the time of manufacture and packaging, and released for transportation without known damage. Upon receipt, inspect the exterior for evidence of rough handling in shipment. Ensure that the appliance is labelled correctly for the gas and electrical supply, and/or other services it is intended to be connected to.

For safety and warranty purposes, appliances that may be damaged or incorrect **MUST NOT** be installed or operated under any circumstances. Installation of damaged or incorrect appliances may contravene local government regulations. Rinnai disclaims any liability or responsibility whatsoever in relation to the installation or operation of damaged or incorrect appliances.



WARNINGS FOR PRODUCT USE

- If an abnormal situation arises (like a burning smell), immediately turn off the unit and disconnect the power. Call your dealer for instructions to avoid electric shock, fire or injury.
- **DO NOT** insert fingers, rods or other objects into the air inlet or outlet. This may cause injury, since the fan may be rotating at high speeds.
- **DO NOT** use flammable sprays such as hair spray, lacquer or paint near the unit. This may cause fire or combustion.
- **DO NOT** operate the air conditioner in places near or around combustible gases. Emitted gas may collect around the unit and cause explosion.
- **DO NOT** operate your air conditioner in a wet room such as a bathroom or laundry room. Too much exposure to water can cause electrical components to short circuit.
- **DO NOT** expose your body directly to cool air for a prolonged period of time.
- **DO NOT** allow children to play with the air conditioner. Children must be supervised around the unit at all times.
- If the air conditioner is used together with burners or other heating devices, thoroughly ventilate the room to avoid oxygen deficiency.
- In certain functional environments, such as kitchens, server rooms, etc., the use of specially designed air-conditioning units is highly recommended.



ELECTRICAL WARNINGS

- If any electrical cables are damaged, they **MUST** be replaced by a suitably qualified and trained service person in order to avoid any potential hazards.
- The product **MUST** be properly earthed at the time of installation, or electrical shock may occur.
- For all electrical work, follow all local and national wiring standards, regulations, and the Installation Manual. Connect cables tightly, and clamp them securely to prevent external forces from damaging the terminal. Improper electrical connections can overheat and cause fire, and may also cause shock. All electrical connections must be made according to the Electrical Connection Diagram located on the panels of the indoor and outdoor units.
- Appropriately specified and sized cables **MUST** be used, ensure all connections are tight. Clamp all cables sufficiently so that they cannot be pulled loose or disconnected.
- All wiring **MUST** be properly arranged to ensure that the control board cover can close properly. If the control board cover is not closed properly, it can lead to corrosion and cause the connection points on the terminal to heat up, catch fire, or cause electrical shock.
- A correctly specified and sized circuit breaker **MUST** be installed in accordance with all local and national wiring standards. A dedicated, independent electrical circuit is required for the system.
- **DO NOT** share the electrical outlet with other appliances. Improper or insufficient power supply can cause fire or electrical shock.
- If connecting power to fixed wiring, an all-pole disconnection device which has at least 3mm clearances in all poles, and have a leakage current that may exceed 10mA, the residual current device (RCD) having a rated residual operating current not exceeding 30mA, and disconnection must be incorporated in the fixed wiring in accordance with wiring rules.



Turn off the air conditioner and switch mains power off if you are not going to use it for a long time.

- Turn off and unplug the unit during storms.
- Make sure that water condensation can drain unhindered from the unit.
- Do not operate the air conditioner with wet hands. This may cause electric shock.
- Do not use device for any other purpose than its intended use.
- Do not climb onto or place objects on top of the outdoor unit.
- Do not allow the air conditioner to operate for long periods of time with doors or windows open, or if the humidity is very high.

SAFETY PRECAUTIONS



PRODUCT INSTALLATION WARNINGS

- Installation must be performed by an authorised dealer or specialist. Defective installation can cause water leakage, electrical shock, or fire.
- Installation must be performed according to the installation instructions and installed by an Authorised Person only. Improper installation can cause water leakage, electrical shock, or fire.
- Contact an authorised service technician for repair or maintenance of this unit. This appliance shall be installed in accordance with current wiring regulations.
- Only use the included accessories, parts, and specified parts for installation. Using non-standard parts can cause water leakage, electrical shock, fire, and can cause the unit to fail.
- Install the unit in a firm location that can support the unit’s weight. If the chosen location cannot support the unit’s weight, or the installation is not done properly, the unit may drop and cause serious injury and damage.
- Install drainage piping according to the instructions in this manual. Improper drainage may cause water damage to your home and property.
- For units that have an auxiliary electric heater, do not install the unit within 1 metre of any combustible materials.
- **DO NOT** install the unit in a location that may be exposed to combustible gas leaks. If combustible gas accumulates around the unit, it may cause fire.
- **DO NOT** install the indoor unit under a floor or beneath a deck, to be installed in a roof space only.
- **DO NOT** turn on the power until all work has been completed.
- When moving or relocating the air conditioner, consult experienced service technicians for disconnection and reinstallation of the unit.
- How to install the appliance to its support, please read the information for details in “indoor unit installation” and “outdoor unit installation” sections.



FLUORINATED GASES

- This air-conditioning unit contains fluorinated greenhouse gases. For specific information on the type of gas and the amount, please refer to the relevant label on the unit itself or the “Owner’s Manual” in the packaging of the outdoor unit.
- Installation, service, maintenance and repair of this unit must be performed by a certified technician.
- Product uninstallation and recycling must be performed by a certified technician.
- For equipment that contains fluorinated greenhouse gases in quantities of 5 tonnes of CO₂ equivalent or more, but less than 50 tonnes of CO₂ equivalent, if the system has a leak- detection system installed, it must be checked for leaks at least every 24 months.
- When the unit is checked for leaks, proper record-keeping of all checks is strongly recommended



FUSE SPECIFICATIONS

The air conditioner’s circuit board (PCB) is designed with a fuse to provide overcurrent protection. The specifications of the fuse are printed on the circuit board, such as:

- T5A/250VAC, T10A/250VAC, etc.
- T20A/250VAC(<=7kW units), T30A/250VAC(>7kW units)

NOTE: For the units with R32, only the blast-proof ceramic fuse can be used.



A NOTE ON ILLUSTRATIONS

The illustrations used in this manual are for explanatory purposes only and the shape of your indoor unit may vary slightly from that which is shown in this manual.



USING R32 REFRIGERANT

When flammable refrigerant are employed, appliance shall be stored in a well-ventilated area where the room size corresponds to the room area as specified for operation.

Appliance shall be installed, operated and stored in a room with a floor area larger than X m². Appliance **MUST NOT** be installed in a unventilated space, if that space is smaller than X m².



REFRIGERANT

This appliance uses R32 (difluoromethane) refrigerant, which is a flammable gas class A2L according to AS 5149.1 and must be handled by a refrigeration mechanic with an appropriate Australian refrigerant handling licence.



WARNING Risk of fire / flammable material. If the refrigerant is leaked, together with an external ignition source, there is a possibility of ignition.



Read the OPERATING INSTRUCTIONS carefully before operation.



Service personnel are required to carefully read the OPERATING INSTRUCTIONS and INSTALLATION MANUAL before operation.



Further information is available in the OPERATING INSTRUCTIONS, INSTALLATION MANUAL, and the like.

Certain levels of refrigerant require minimum room sizes. Please ensure that these minimum room sizes are adhered to for standard installations (up to 15m pipe length). If larger refrigerant charges than standard are used then please consult AS/NZS 60335.2.40 to determine the safe minimum floor area for the installation.

Make sure that the area has been made safe by having suitable ventilation and is free from ignition sources before charging or releasing the charge of R32.

Minimum Room Size

Amount of refrigerant to be charged (kg)	Installation height (m)	Minimum room area (m ²)
1.2	0.6 / 1.8 / 2.2	12.5 / 1.5 / 1
1.25	0.6 / 1.8 / 2.2	13.5 / 1.5 / 1
1.3	0.6 / 1.8 / 2.2	14.5 / 2 / 1.5
1.35	0.6 / 1.8 / 2.2	16 / 2 / 1.5
1.4	0.6 / 1.8 / 2.2	17 / 2 / 1.5
1.45	0.6 / 1.8 / 2.2	18 / 2 / 1.5
1.5	0.6 / 1.8 / 2.2	19.5 / 2.5 / 1.5
1.55	0.6 / 1.8 / 2.2	21 / 2.5 / 2
1.6	0.6 / 1.8 / 2.2	22 / 2.5 / 2
1.65	0.6 / 1.8 / 2.2	23.5 / 3 / 2
1.7	0.6 / 1.8 / 2.2	25 / 3 / 2
1.75	0.6 / 1.8 / 2.2	26.5 / 3 / 2
1.8	0.6 / 1.8 / 2.2	28 / 3.5 / 2.5
1.85	0.6 / 1.8 / 2.2	29.5 / 3.5 / 2.5
1.9	0.6 / 1.8 / 2.2	31 / 3.5 / 2.5
1.95	0.6 / 1.8 / 2.2	33 / 4 / 2.5
2.0	0.6 / 1.8 / 2.2	34.5 / 4 / 3
2.05	0.6 / 1.8 / 2.2	36 / 4 / 3

Amount of refrigerant to be charged (kg)	Installation height (m)	Minimum room area (m ²)
2.1	0.6 / 1.8 / 2.2	38 / 4.5 / 3
2.15	0.6 / 1.8 / 2.2	40 / 4.5 / 3
2.2	0.6 / 1.8 / 2.2	41.5 / 5 / 3.5
2.25	0.6 / 1.8 / 2.2	43.5 / 5 / 3.5
2.3	0.6 / 1.8 / 2.2	45.5 / 5 / 3.5
2.35	0.6 / 1.8 / 2.2	47.5 / 5.5 / 4
2.4	0.6 / 1.8 / 2.2	49.5 / 5.5 / 4
2.45	0.6 / 1.8 / 2.2	51.5 / 6 / 4
2.5	0.6 / 1.8 / 2.2	54 / 6 / 4
2.55	0.6 / 1.8 / 2.2	56 / 6.5 / 4.5
2.6	0.6 / 1.8 / 2.2	58 / 6.5 / 4.5
2.65	0.6 / 1.8 / 2.2	60.5 / 7 / 4.5
2.7	0.6 / 1.8 / 2.2	63 / 7 / 5
2.75	0.6 / 1.8 / 2.2	65 / 7.5 / 5
2.8	0.6 / 1.8 / 2.2	67.5 / 7.5 / 5
2.85	0.6 / 1.8 / 2.2	70 / 8 / 5.5
3.6	0.6 / 1.8 / 2.2	111 / 12 / 8
4.3	0.6 / 1.8 / 2.2	159 / 18 / 12

- All minimum room sizes in the above table are calculated on the base charge provided with the outdoor unit.

- Mechanical connectors used indoors shall comply with ISO 14903.
- This appliance shall be installed in accordance with AS/NZS 5149.
- When mechanical connectors are reused, sealing parts shall be renewed.
- When flared joints are reused, the flare part shall be re-fabricated.

DISPOSAL GUIDELINES

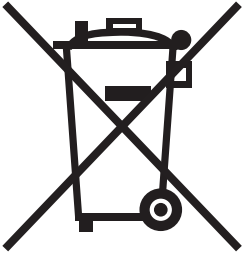

This appliance contains refrigerant and other potentially hazardous materials. When disposing of this appliance, the law requires special collection and treatment. **DO NOT** dispose of this product as household waste or unsorted municipal waste.



Special notice – Disposing of this appliance in the forest or other natural surroundings endangers your health and is bad for the environment. Hazardous substances may leak into the ground water and enter the food chain.



CLEANING AND MAINTENANCE WARNINGS

- Turn off the device and switch the mains power off before cleaning. Failure to do so can cause electric shock
- **DO NOT** clean the air conditioner with excessive amounts of water.
- **DO NOT** clean the air conditioner with combustible cleaning agents. Combustible cleaning agents can cause fire or deformation

SPECIFICATIONS

INSTALLING MULTIPLE UNITS

Number of units that can be used together	Connected units	1-6 units
Compressor stop/start frequency	Stop time	3 min or more
Power Source Voltage	Voltage fluctuation	Within $\pm 10\%$ of rated voltage
	Voltage drop during start	Within $\pm 15\%$ of rated voltage
	Interval unbalance	Within $\pm 3\%$ of rated voltage

	Unit / m					
	MON2H05B1LA	MON3H07B1LA	MON4H09B1LA	MON5H11B1LA	MON5H14B1LA	MON6H19B1TA
	2 Head	3 Head	4 Head	5 Head	5 Head	6 Head
Max. length for all rooms	40	60	80	80	80	80
Max. length for one indoor unit	25	30	35	35	35	35
Max. height difference between indoor and outdoor unit	15	15	15	15	15	15
Max. height difference between indoor units	10	10	10	10	10	10



For the units adopt quick connectors, no more than two pipes can be connected, and the maximum length for each pipe is 7.5m.

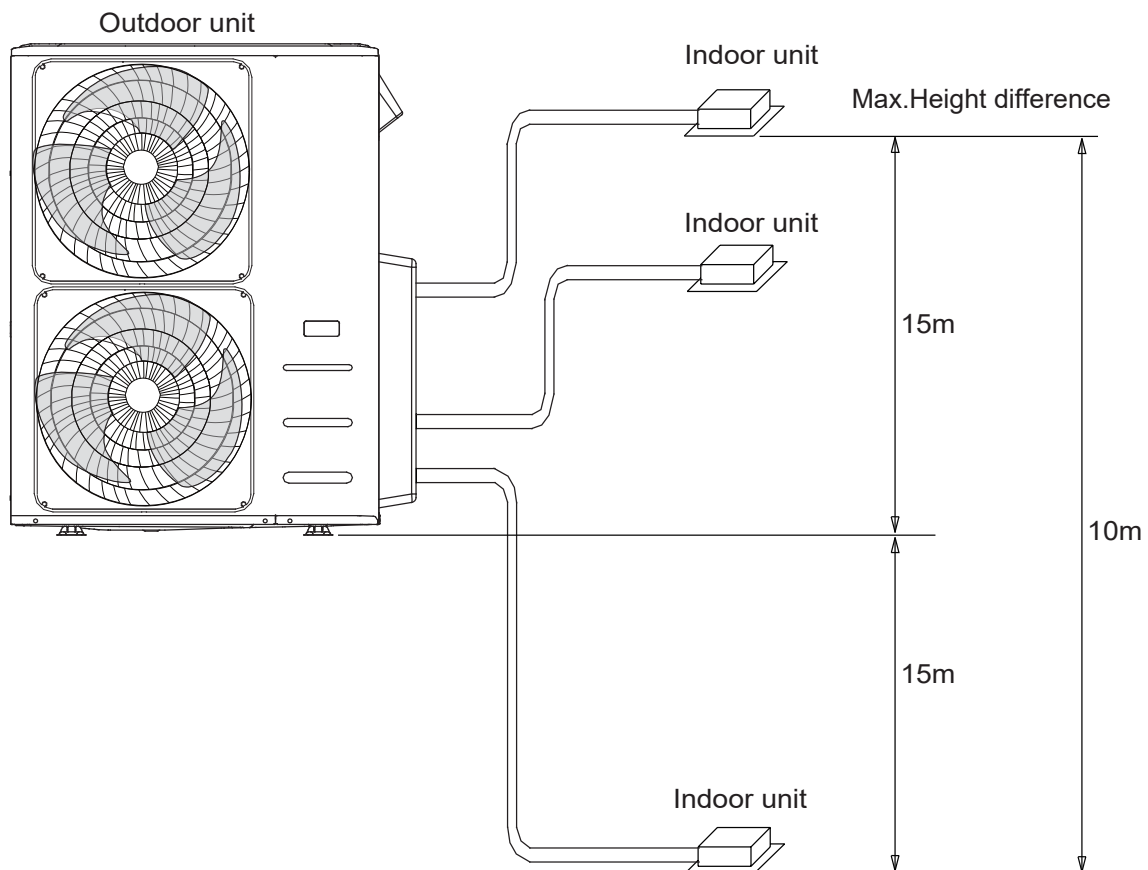

TECHNICAL SPECIFICATIONS

MULTI OUTDOOR UNIT			MON2H05B1LA	MON3H07B1LA	MON4H09B1LA	MON5H11B1LA	MON5H14B1LA	MON6H19B1TA
Number of connected Indoor Units		Qty	2	3	4	5	5	6
Power Supply (To Outdoor Unit)		V-Ph-Hz	220~240-1-50					
Cooling	Rated Capacity (Range)	kW	5.4 (1.0-7.2)	7.2 (3.2-8.2)	9.0 (2.7- 10.3)	11.6 (2.6-15.1)	13.5 (2.6-15.1)	19 (5.4-19.6)
	Rated Input Power	kW	1.48	1.97	2.39	3128.00	3.91	5.58
	Rated Input Current	A	6.7	9.1	10.8	14.0	17.5	24.1
	AEER	W/W	3.58	3.58	3.70	3.643	3.40	3.42
Heating	Rated Capacity (Range)	kW	5.4 (1.9-5.9)	7.3 (2.1-8.8)	9.5 (2.8-10.3)	12.5 (2.6-16.3)	14 (2.6-16.3)	21.5 (3.9-22.6)
	Rated Input Power	W	1.32	1.61	2.32	2.78	3.26	5.10
	Rated Input Current	A	6.0	7.6	10.5	12.4	14.5	29.0
	ACOP	W/W	4.00	4.41	4.01	4.415	4.22	4.16
Maximum Input Current		A	12	17.5	19	30	30	33
Recommended Circuit Breaker		A	25	25	25	35	35	40
Compressor		Type	Inverter Rotary	Inverter Twin Rotary				
Sound Power Level		dB(A)	61	65	68	68	70	72
Dimensions	Net (W x D x H)	mm	805 x 330 x 554	890 x 342 x 673	946 x 410 x 810	980 x 451 x 975	980 x 451 x 975	952 x 415 x 1333
	Gross (W x D x H)	mm	915 x 370 x 615	1030 x 438 x 815	1090 x 500 x 965	1145 x 500 x 1120	1145 x 500 x 1120	1095 x 495 x 1500
	Net / Gross Weight	kg	34.6 / 37.7	48.0 / 61.5	66.2 / 83.0	91.0 / 106.4	91.0 / 106.4	110.6 / 124.9
Refrigerant Type			R32					
Refrigerant Piping	Connection Size: Liquid Line	mm	2 x Φ 6.35	3 x Φ 6.35	4 x Φ 6.35	5 x Φ 6.35	5 x Φ 6.35	6 x Φ 6.35
	Connection Size: Gas	mm	2 x Φ 9.52	3 x Φ 9.52	3 x Φ 9.52 + 1 x Φ 12.7	3 x Φ 9.52 + 2 x Φ 12.7	3 x Φ 9.52 + 2 x Φ 12.7	4 x Φ 9.52 + 2 x Φ 12.7
	Max. Total System Pipe Length	m	40	60	80	80	80	80
	Pre-Charged Length	m	20	30	40	50	50	60
	Max. Length Per Indoor Unit	m	25	30	35	35	35	35
	Max. Vertical Separation Outdoor Unit ABOVE Indoor Unit	m	15	15	15	15	15	15
	Max. Vertical Separation Outdoor Unit BELOW Indoor Unit	m	15	15	15	15	15	15
	Max. Height Difference Between Indoor Units	m	10	10	10	10	10	10
	Factory Pre-charge	g	1250	1850	2400	3600	3600	4300
	Additional pre-charge	g/m	Liquid Side: Φ 6.35(Φ 1/4") R32 (Total pipe length - The standard pipe length) \times 12g/m Liquid Side: Φ 9.52(Φ 3/8") R32 (Total pipe length - The standard pipe length) \times 24g/m					
Ambient Temperature Limits	Cooling	$^{\circ}$ C	-15~50					
	Heating	$^{\circ}$ C	-15~24					

HI-WALL - PX SERIES			HINRPX20M	HINRPX25M	HINRPX35M	HINRPX50M	HINRPX60M	HINRPX70M	HINRPX80M
Power Supply		V - Ph - Hz	220-240 - 1 - 50						
Cooling	Rated Capacity	kW	2.0	2.6	3.5	5.0	6.0	7	7.95
	Rated Power Input	W	31	31	37	88	88	114	114
	Rated Current	A	0.31	0.31	0.37	0.7	0.7	0.88	0.88
Heating	Rated Capacity	kW	2.3	3.25	3.8	6.0	6.55	7.7	8.7
	Rated Power Input	W	31	31	37	88	88	114	114
	Rated Current	A	0.31	0.31	0.37	0.7	0.7	0.88	0.88
Air Flow (Turbo / Hi / Med / Lo / Min)		L/s	208 / 153 / 111 / 86 / 43	208 / 153 / 111 / 86 / 43	222 / 167 / 125 / 103/61	339 / 256 / 183 / 150 / 89	339 / 256 / 183 / 150 / 89	336 / 289 / 244 / 198 / 114	336 / 289 / 244 / 198 / 114
Sound Pressure Level @ 1m (Turbo / Hi / Med / Lo / Min)		dB(A)	47.0 / 38.0 / 33.0 / 26.0 / 20.0	47 / 39 / 33 / 26.5 / 20.5	46.5 / 39.5 / 33.5 / 27 / 21	49.5 / 43.0 / 36.5 / 28.5 / 19.5	49.5 / 43.0 / 36. / 28.5 / 19.5	52 / 46 / 43 / 38 / 37.5	52 / 46 / 43 / 38 / 37.5
Air Swing Louvres		Direction	4-way swing						
Dimensions	Dimension (W x D x H)	mm	813 x 201 x 289	813 x 201 x 289	813 x 201 x 289	975 x 218 x 308	975x218x308	1055 x 231 x 330	1055 x 231 x 330
	Packing (W x D x H)		885 x 280 x 358	885 x 280 x 358	885 x 280 x 358	1065 x 300 x 380	1065 x 300 x 380	1140 x 420 x 325	1140 x 420 x 325
	Net / Gross Weight	kg	8.0 / 10.4	8.0 / 10.4	8.2 / 10.5	10.7 / 14.3	10.7/14.3	13.0/16.5	13.0 / 16.5
Refrigerant Pipe Size: Liquid / Gas		mm	6.35mm / 9.52mm	6.35mm / 9.52mm	6.35mm / 9.52mm	6.35mm / 12.7mm	6.35mm / 12.7mm	6.35mm / 15.9mm	6.35mm / 15.9mm
Controller		Type	Wireless Remote Control						
Operating range	Cooling	°C	16~32						
	Heating		0~30						
Wi-Fi Compatibility			Standard						

SLIM DUCTED			DINSD26MBA	DINSD35MBA	DINSD50MBA	
Power Supply			V-Ph-Z	220-240-1-50		
Cooling	Rated Capacity	kW	2.60	3.50	5.28	
	Rated Input Power	W	88	91	172	
	Rated Input Current	A	0.66	0.67	1.12	
Heating	Rated Capacity	kW	2.90	3.80	6.00	
	Rated Input Power	W	88	91	172	
	Rated Input Current	A	0.66	0.67	1.12	
Airflow (Hi/Med/Lo)			L/s	172 / 150 / 125	183 / 158 / 131	250 / 217 / 181
Maximum External Static Pressure			Pa	100	100	160
Sound Pressure Level @1.0m (Hi/Med/Lo)			dB(A)	35 / 33 / 31 / 27	35 / 33 / 31 / 26	36.5 / 34 / 31 / 25
Dimensions	Net (W x D x H)	mm	700 x 450 x 200	700 x 450 x 200	700 x 750 x 245	
	Gross (W x D x H)		860 x 540 x 285	860 x 540 x 285	925 x 850 x 298	
	Net / Gross Weight	kg	16.6 / 19.8	16.6 / 19.8	24.4 / 29	
	Supply Air Duct Connection (W x H)	mm	537 x 152	537 x 152	527 x 178	
	Return Air Duct Connection (W x H)		599 x 186	599 x 186	592 x 212	
	Refrigerant Pipe Size: Liquid / Gas	mm	6.35 / 9.52	6.35 / 9.52	6.35 / 12.7	
Condensate Drain Pump Connection	Φ25		Φ25	Φ25		
Controller			Type	Wired controller - 2-wired wiring (Field Supply)		
Operating Range	Cooling	°C	16-32			
	Heating		0-30			
Wi-Fi Compatibility				Standard		

DUCTED			DINLR07B1A	DINLR09B1A	DINLR11B1A
Power Supply		V-Ph-Z	220-240-1-50		
Cooling	Rated Capacity	kW	7.3	9.0	10.5
	Rated Input Power	W	145	280	302
	Rated Input Current	A	1	1.72	1.83
Heating	Rated Capacity	kW	7.5	10.5	12.5
	Rated Input Power	W	145	280	302
	Rated Input Current	A	1	1.72	1.83
Indoor Air Flow (Turbo / Hi / Mi / Lo / Silence)		L/s	472 / 417 / 361 / 278 / 194	639 / 556 / 500 / 417 / 139	722 / 611 / 528 / 417 / 167
Maximum External Static Pressure		Pa	160	160	200
Indoor Noise Level Turbo / (Hi / Mi / Lo / Silence) @1.5m		dB(A)	41 / 38 / 36 / 33 / 28	46 / 40 / 38 / 36 / 28	45 / 39 / 37.5 / 36 / 30
Dimensions	Net (W x D x H)	mm	1000 x 750 x 245	1200 x 750 x 245	1200 x 750 x 300
	Gross (W x D x H)		1225 x 860 x 304	1425 x 860 x 304	1425 x 860 x 359
	Net / Gross Weight	kg	31.5 / 36.9	40.5 / 46.5	42.9 / 48.9
	Supply Air Duct Connection (W x H)	mm	827 / 178	1027 / 178	1027 / 233
	Return Air Duct Connection (W x H)		892 / 212	1092 / 212	1092 / 267
	Refrigerant Pipe Size: Liquid / Gas	mm	9.52 / 15.9	9.52 / 15.9	9.52 / 15.9
	Condensate Drain Pump Connection		Φ25	Φ25	Φ25
Controller		Type	Wired controller - 2-wired wiring (Field Supply)		
Operating Range	Cooling	°C	16-32		
	Heating		0-30		
Wi-Fi Compatibility			Standard		





COMPACT CASSETTES			CIN020RMB	CIN026RMB	CIN035RMB	CIN050RMB
Fascia Panel		Model No.	CINFASMB			
Power Supply		V-Ph-Z	220-240-1-50			
Cooling	Rated Capacity	kW	2.00	2.60	3.50	5.30
	Rated Input Power	W	25	25	40	45
	Rated Input Current	A	0.25	0.25	0.40	0.40
Heating	Rated Capacity	kW	2.30	2.90	3.50	5.50
	Rated Input Power	W	25	25	40	45
	Rated Input Current	A	0.25	0.25	0.40	0.45
Airflow (Hi / Med / Lo)		L/s	139 / 128 / 111	139 / 128 / 111	172 / 144 / 92	183 / 150 / 83
Sound Pressure Level @1.0m (Hi/Med/Lo)		dB(A)	40 / 37 / 27	40 / 37 / 27	42 / 38 / 31	44 / 41 / 31.5
Dimensions	Net - Body (W x D x H)	mm	570 x 570 x 245	570 x 570 x 245	570 x 570 x 245	570 x 570 x 245
	Gross - Body (W x D x H)		715 x 640 x 295	715 x 640 x 295	715 x 640 x 295	715 x 640 x 295
	Net - Fascia (W x D x H)		620 x 620 x 50			
	Gross - Fascia (W x D x H)		715 x 700 x 115			
	Net / Gross Weight - Body	kg	14.6 / 17.5	14.6 / 17.5	14.6 / 17.5	14.6 / 17.5
	Net / Gross Weight - Fascia		2.7/4.3			
	Refrigeration Pipe Size: Liquid / Gas	mm	Φ6.35 / Φ9.52	Φ6.35 / Φ9.52	Φ6.35 / Φ9.52	Φ6.35 / Φ12.7
	Condensate Drain Pump Connection		Φ25	Φ25	Φ25	Φ25
Controller		Type	Remote controller			
Operating Range	Cooling	°C	16-32			
	Heating		0-30			
Wi-Fi Compatibility			Standard			

FLOOR CONSOLE		FINRP50B	
Power Supply		V-Ph-Hz	220-240V,1Ph,50Hz
Cooling (Standard conditions)	Rated Capacity	kW	4.90
	Rated Power Input	W	80
	Rated Current	A	0.70
Heating (Standard conditions)	Rated Capacity	kW	5.50
	Rated Power Input	W	80
	Rated Current	A	0.7
Sound Power Level		dB(A)	54
Indoor unit	Dimension (W x D x H)	mm	794 x 200 x 621
	Packing (W x D x H)	mm	865 x 280 x 719
	Net/Gross Weight	kg	14.9 / 18.8
Wi-Fi Compatibility		Standard	

OUTDOOR UNIT INSTALLATION

OUTDOOR UNIT ACCESSORIES

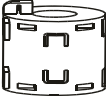
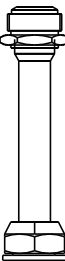
The air conditioning system comes with the following accessories. Use all of the installation parts and accessories to install the air conditioner. Improper installation may result in water leakage, electrical shock and fire, or cause the equipment to fail. The items are not included with the air conditioner must be purchased separately.

Name of Accessories	Qty (pc)	Shape	Name of Accessories	Qty (pc)	Shape
Manual	2~4		Drain joint	1	
Installation plate (some models)	1		Seal ring (some models)	1	
Plastic expansion sheath (some models)	5-8 (depending on models)		Magnetic ring. Hitch it on the connective cable between indoor unit and outdoor unit after installation (some models).	Varies by model	
Self-Tapping Screw A (some models)					
Pipe Adapter	1		Cord protection rubber ring. If the cord clamp cannot fasten on a small cord, use the cord protection rubber ring (supplied with accessories) to wrap around the cord. Then fix it in place with the cord clamp (some models).	1	
NOTE: Pipe size may differ from appliance to appliance. To meet different pipe size requirements, sometimes the pipe connections need a transfer connector installed on the outdoor unit. Supplied adapters to suit most combinations. If other adapters required, they should be field supplied.					

Rinnai Model	Additional Connector (quantity)						
	Φ6.35→9.52	Φ9.52→12.7	Φ9.52→15.9	Φ12.7→15.9	Φ9.52→6.35	Φ12.7→9.52	Φ15.9→12.7
MON2H05B1LA		1					
MON3H07B1LA		1				2	
MON4H09B1LA	1	1		1	1	1	
MON5H11B1LA	2	2		2		2	
MON5H14B1LA	2	2		2		2	
MON6H19B1TA	2	1		2		2	

OPTIONAL ACCESSORIES

- There are two types of remote controls: wired and wireless. Select a remote controller based on customer preferences and requirements and install in an appropriate place. Refer to catalogues and technical literature for guidance on selecting a suitable remote controller.

Name	Shape	(mm)	Quantity (pc)
Connecting pipe assembly	Liquid side	Φ6.35	Parts you must purchase separately. Consult the dealer about the proper pipe size of the unit you purchased.
		Φ9.52	
	Gas side	Φ9.52	
		Φ12.7	
		Φ16	

INSTALLATION SUMMARY

INSTALLATION ORDER

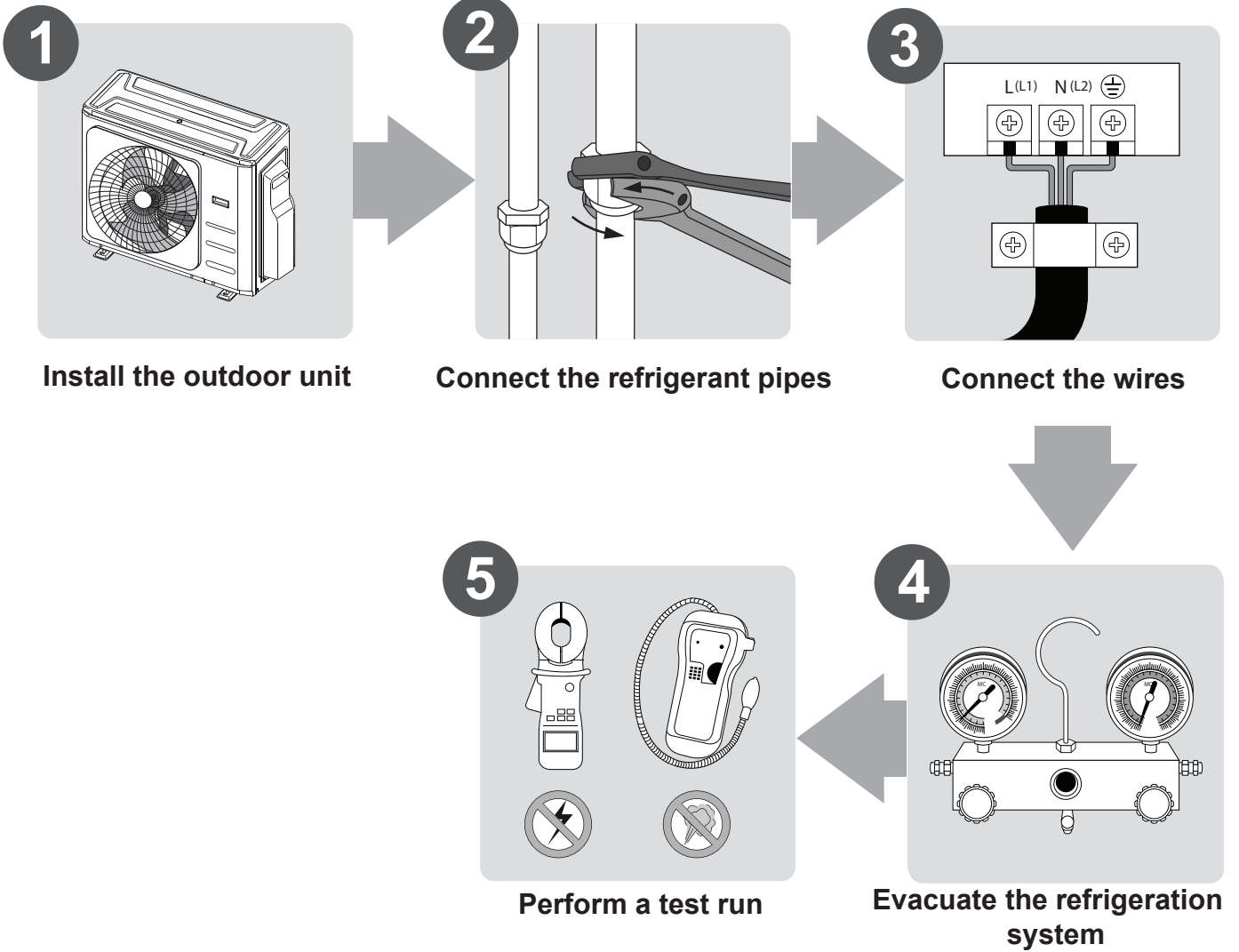

OUTDOOR INSTALLATION

Install the unit by following your Local Regulations and Municipal Building Codes. They may differ slightly between states.

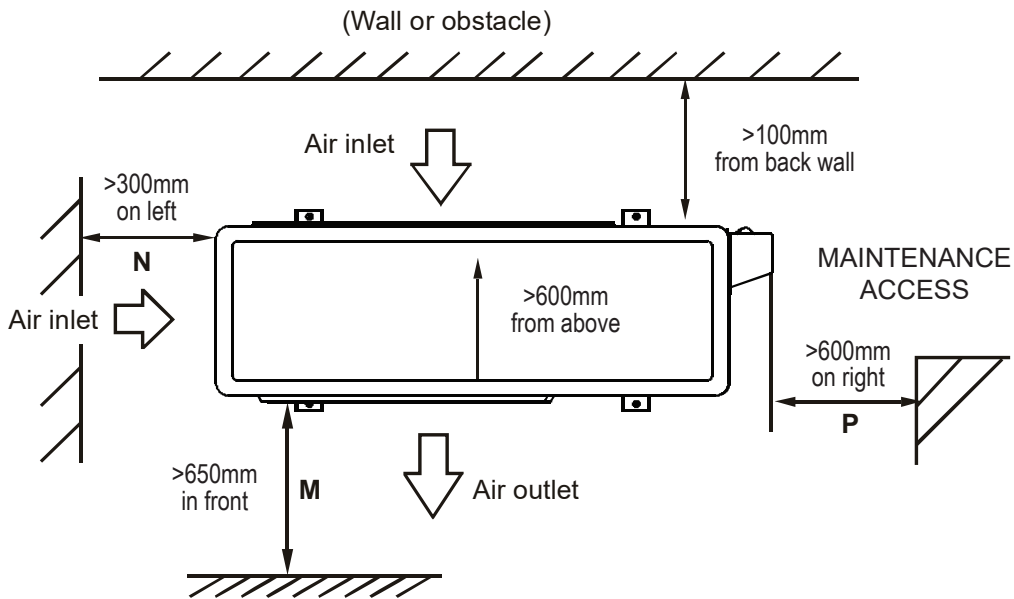

Figure 1.

INSTALLATION INSTRUCTIONS – OUTDOOR UNIT

Step 1. Installation position

The outdoor unit shall be installed in a location that satisfies the following requirements:

- There is sufficient room for installation and maintenance.
- The condenser air path is not blocked or impeded, and cannot be adversely affected by strong prevailing winds.
- It must be in a dry and well ventilated place.
- The supporting structure is flat, horizontal and can withstand the full operating weight of the outdoor unit. The base must be free of vibration.
- Positioned so as to prevent operating noise interference to others.
- Easy installation of interconnecting refrigerant pipes and wiring.
- Arrange condenser air discharge to be free, unimpeded, and not blocked or obstructed.
- Away from any potential fire risks, or flammable materials.
- The refrigerant pipe length or height difference between outdoor and indoor does not exceed the maximum allowable limits.
- For installations prone or exposed to strong prevailing winds or breezes such as coastal areas, please ensure that the unit is sited appropriately, by placing it lengthwise along the wall to reduce any negative impact on the condenser fans. Refer to "Figure 2." on page 17.
- If possible, do not install the unit where it is exposed to direct sunlight, this will negatively impact cooling performance.
- In heating mode, the outdoor unit will produce condensate water. This condensate needs to be properly drained to waste in accordance with all applicable local and national plumbing regulations.
- Select unit location where it will not be subject to the accumulation of snow, leaves or other seasonal debris. This may negatively impact the performance and longevity of the units.
- Locate the outdoor unit as close as possible to the indoor unit to reduce performance losses.

- If possible, please remove any obstacles nearby to prevent the system performance being negatively impacted by compromised condenser air circulation.
- The minimum distance between the outdoor unit and walls/obstacles described in the installation chart does not correlate directly to installations in enclosed spaces. In these cases at least two of the three sides should remain open (M, N, P). Refer to "Figure 1." on page 16

DO NOT install unit in the following locations:

- Near an obstacle that will block air inlets and outlets
- Near a public street, crowded areas, or where noise from the unit will disturb others
- Near animals or plants that will be harmed by hot air discharge
- Near any source of combustible gas
- In a location that is exposed to large amounts of dust
- In a location exposed to excessive amounts of salty air

SPECIAL CONSIDERATIONS FOR EXTREME WEATHER

If the unit is exposed to heavy wind

Install unit so that air outlet fan is at a 90° angle to the direction of the wind. If needed, build a barrier in front of the unit to protect it from extremely heavy winds. Refer to Figure 2 below.

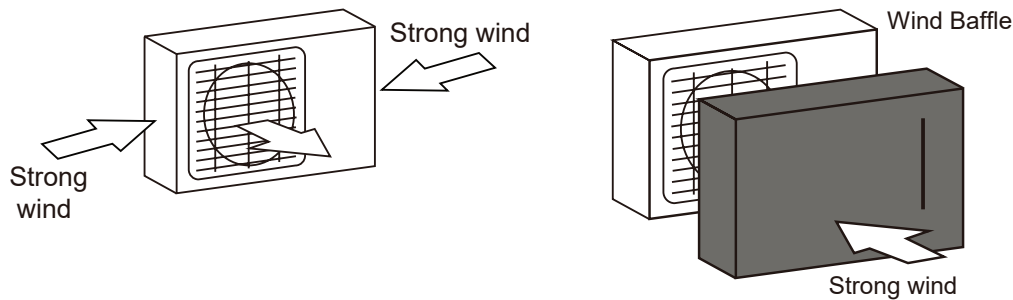

Figure 2.



If the unit is frequently exposed to heavy rain or snow:

- **Build a shelter above the unit to protect it from the rain or snow. Be careful not to obstruct air flow around the unit.**

If the unit is frequently exposed to salty air (seaside):

- **Use outdoor unit that is specially designed to resist corrosion.**

Step 2. Install drain joint (Heat pump unit only)

Before bolting the outdoor unit in place, you must install the drain joint at the bottom of the unit. Note that there are two different types of drain joints depending on the type of outdoor unit.

If the drain joint comes with a rubber seal (see Figure 3), do the following:

- Fit the rubber seal on the end of the drain joint that will connect to the outdoor unit.
- Insert the drain joint into the hole in the base pan of the unit.
- Rotate the drain joint 90° until it clicks in place facing the front of the unit.
- Connect a drain hose extension (not included) to the drain joint to redirect water from the unit during heating mode.

OUTDOOR INSTALLATION

If the drain joint doesn't come with a rubber seal (see Figure 4), do the following:

- Insert the drain joint into the hole in the base pan of the unit. The drain joint will click in place.
- Connect a drain hose extension (not included) to the drain joint to redirect water from the unit during heating mode.

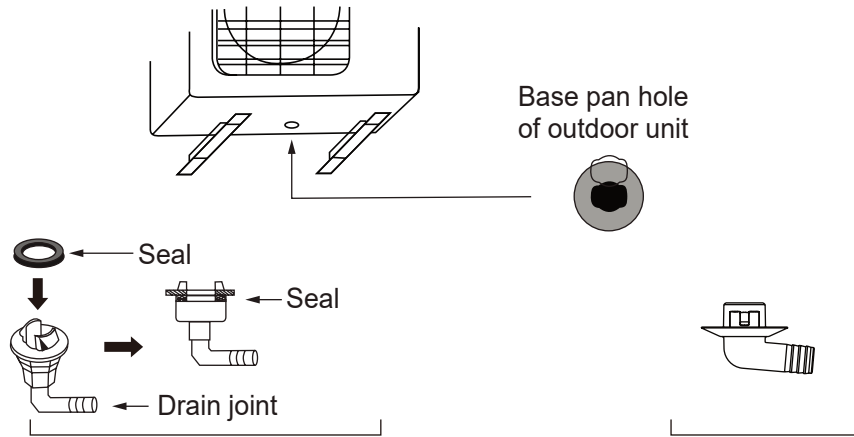

Figure 3.

Figure 4.



The condensate drain terminal point must comply with Local Regulations and Municipal Building codes or refer to AS/NZS 3500 Plumbing and Drainage.



IN COLD CLIMATES

Always turn off the power to your air conditioner system and isolate its power supply before you perform any cleaning or maintenance; otherwise it may cause electric shock.

In cold climates, make sure that the drain hose is as vertical as possible to ensure swift water drainage. If water drains too slowly, it can freeze in the hose and flood the unit. Insulating the drain hose in cold climates is recommended.

Step 3. Anchor outdoor unit

The outdoor unit can be anchored to the ground or to a wall-mounted bracket with bolt (M10). Prepare the installation base of the unit according to the dimensions on the following page.



To reduce the transmission of vibration and noise, waffle pad shall be installed beneath the unit at each anchor point.

UNIT MOUNTING DIMENSIONS

The following is a list of different outdoor unit sizes and the distance between their mounting feet. Prepare the installation base of the unit according to the dimensions below.

Size kW	Outdoor Unit Dimensions (mm) W x D x H	Mounting Dimensions (mm)	
		Distance A	Distance B
5	805 x 554 x 330	551	317
7	890 x 342 x 673	663	354
9	946 x 410 x 810	673	403
11/14	980 x 415 x 975	616	397
19	952 x 1333 x 415	634	404

**Split Type Outdoor Unit
Types & Specifications**

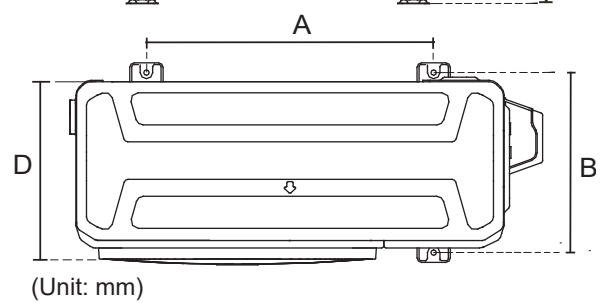
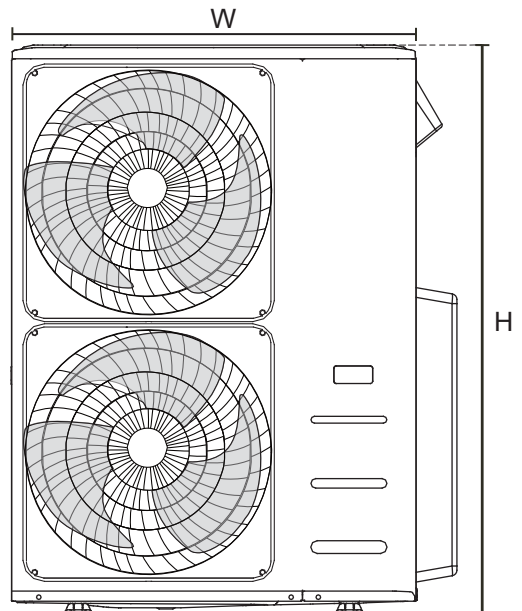
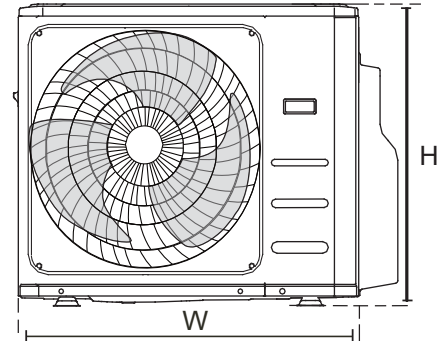

ROWS OF SERIES INSTALLATION

The relations between H, A and L are as follows:

	L	A
L ≤ H	L ≤ 1/2H	25 cm or more
	1/2H < L ≤ H	30 cm or more
L > H	Can not be installed	

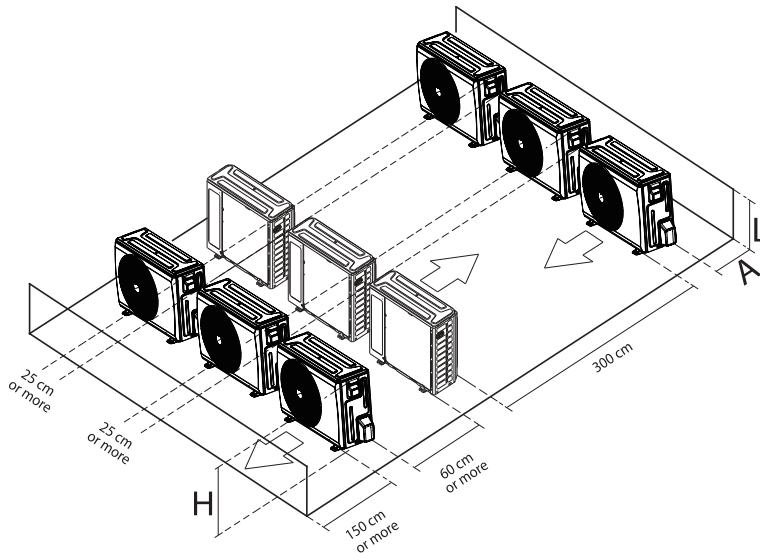

DRILLING HOLE IN WALL

You must drill a hole in the wall for the refrigerant piping, and the signal cable that will connect the indoor and outdoor units.

1. Determine the location of the wall hole based on the location of the outdoor unit.
2. Using a 65-mm core drill, drill a hole in the wall.
3. Place the protective wall cuff in the hole. This protects the edges of the hole and helps seal it when you finish the installation process.



When drilling the wall hole, make sure to avoid wires, plumbing, and other sensitive components.

WHEN SELECTING A 7.0KW & 8.0KW INDOOR UNIT

The 7.0kW & 8.0kW indoor unit can only be connected with an A circuit.

Connective pipe size of an A and B circuit

Indoor Unit capacity (kW)	(Unit mm)	
	Liquid	Gas
2.0 / 2.6 / 3.5	6.35	9.53
5.0 / 6.0	6.35	12.70
7.0 / 8.0	6.35	15.88
Ducted	Liquid	Gas
7 / 9 / 11	9.52	15.88

- If the outdoor unit is installed on roof structures or external walls, this may result in excessive noise and vibration, it may also be classed as a non serviceable installation, and void the manufacturers warranty.

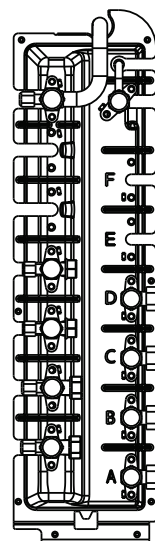

← The largest system to be connected to Circuit A

REFRIGERANT PIPING CONNECTION



For quick-connect models, please refer to the Indoor Unit manual for the installation method of refrigerant piping connection. The Outdoor Unit manual does not repeat the instructions.

When connecting refrigerant piping, **DO NOT** let substances or gases other than the specified refrigerant enter the unit. The presence of other gases or substances will lower the unit's capacity, and can cause abnormally high pressure in the refrigeration cycle. This can cause explosion and injury.



The branching pipe must be installed horizontally. An angle of more than 10° may cause malfunction.

DO NOT install the connecting pipe until both indoor and outdoor units have been installed.

Insulate both the gas and liquid piping to prevent condensing.

Step 1. Cut pipes

When preparing refrigerant pipes, take extra care to cut and flare them properly. This will ensure efficient operation and minimise the need for future maintenance.

- Measure the distance between the indoor and outdoor units.
- Using a pipe cutter, cut the pipe a little longer than the measured distance.
- Make sure that the pipe is cut perfectly at a 90° angle.

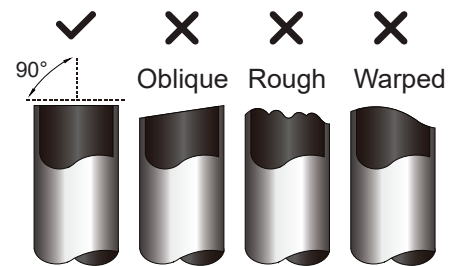

DO NOT DEFORM PIPE WHILE CUTTING.

Be extra careful not to damage, dent, or deform the pipe while cutting. This will drastically reduce the heating efficiency of the unit.

Step 2. Remove burrs

Burrs can affect the air-tight seal of refrigerant piping connection. They must be completely removed.

- Hold the pipe at a downward angle to prevent burrs from falling into the pipe.
- Using a reamer or deburring tool, remove all burrs from the cut section of the pipe.

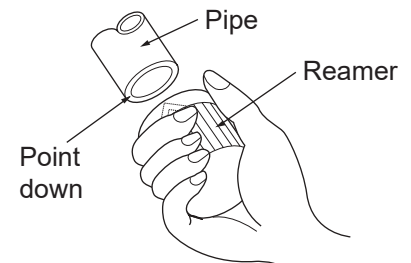

Step 3. Flare pipe ends

Proper flaring is essential to achieve an airtight seal.

- After removing burrs from cut pipe, seal the ends with PVC tape to prevent foreign materials from entering the pipe.
- Sheath the pipe with insulating material.
- Place flare nuts on both ends of pipe. Make sure they are facing in the right direction, because you can't put them on or change their direction after flaring.
- Remove PVC tape from ends of pipe when ready to perform flaring work.
- Clamp flare form on the end of the pipe. The end of the pipe must extend beyond the flare form.
- Place flaring tool onto the form.
- Turn the handle of the flaring tool clockwise until the pipe is fully flared. Flare the pipe in accordance with the dimensions.

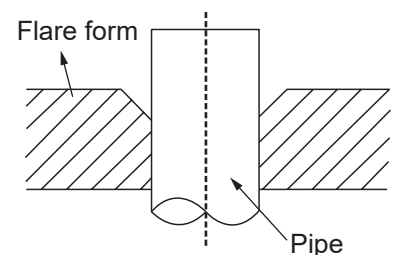
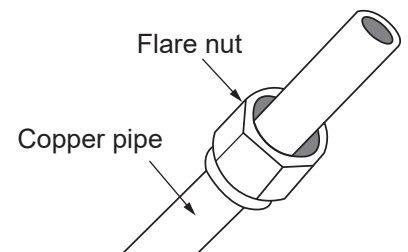

Piping Extension Beyond Flare Form

Pipe gauge	Tightening Torque	Flare dimensions (A) mm		Flare shape
		Min.	Max.	
Ø 6.4	18 - 20 N.m	8.4	8.7	
Ø 9.5	25 - 26 N.m	13.2	13.5	
Ø 12.7	35 - 36 N.m	16.2	16.5	
Ø 15.9	45 - 47 N.m	19.2	19.7	
Ø 19.1	65 - 67 N.m	23.2	23.7	
Ø 22	75 - 85 N.m	26.4	26.9	

- Remove the flaring tool and flare form, then inspect the end of the pipe for cracks and even flaring

Step 4. Connect pipes

Connect the copper pipes to the indoor unit first, then connect it to the outdoor unit. You should first connect the low-pressure pipe, then the high-pressure pipe.

- When connecting the flare nuts, apply a thin coat of compatible refrigeration oil to the flared ends of the pipes.
- Align the centre of the two pipes that you will connect.

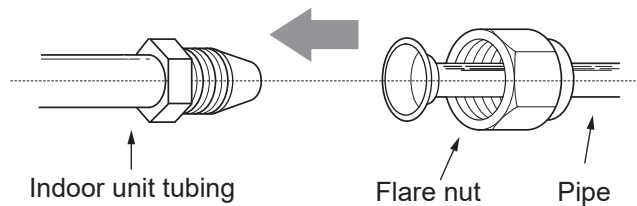

- Tighten the flare nut as tightly as possible by hand.
- Using a spanner, grip the nut on the unit tubing.
- While firmly gripping the nut, use a torque wrench to tighten the flare nut according to the torque values in the table above.

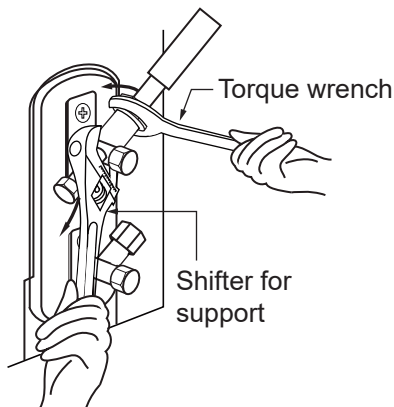

Use both a spanner and a torque wrench when connecting or disconnecting pipes to or from the unit.



Ensure to wrap insulation around the piping. Direct contact with the bare piping may result in burns or frostbite.

Make sure the pipe is connected correctly. Over tightening may damage the bell mouth and under tightening may lead to leakage.

**MINIMUM BEND RADIUS**

Carefully bend the tubing in the middle according to the diagram below. **DO NOT** bend the tubing more than 90° or more than 3 times.

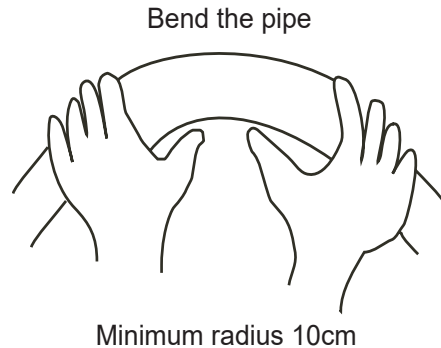

Hands shown are for representation purpose only.

After connecting the copper pipes to the indoor unit, wrap the power cable, signal cable and the piping together with the binding signal tape.



DO NOT intertwine or cross the signal cable with other wires, while bundling these items together.

- Pipe run must be supported every 2m
- R32 flammable refrigerant labels must be placed on the pipe run every 2m
- Thread this pipeline through the wall and connect it to the outdoor unit.
- Insulate all the piping, including the valves of the outdoor unit.
- Open the stop valves of the outdoor unit to start the flow of the refrigerant between the indoor and outdoor unit.



Check to make sure there is no refrigerant leak after completing the installation work. If there is a refrigerant leak, ventilate the area immediately and evacuate the system (refer to the "Air Evacuation" on page 44 of this manual).

WIRING



BEFORE PERFORMING ANY ELECTRICAL WORK, READ THESE REGULATIONS

- All wiring **MUST** comply with local and national electrical codes, regulations and **MUST** be installed by a licensed electrician.
- All electrical connections **MUST** be made according to the Electrical Connection Diagram located on the panels of the indoor and outdoor units.
- If there is a serious safety issue with the power supply, stop work immediately. Explain your reasoning to the client, and refuse to install the unit until the safety issue is properly resolved.
- Power voltage should be within 90-110% of rated voltage. Insufficient power supply can cause malfunction, electrical shock, or fire.
- If connecting power to fixed wiring, a surge protector and main power switch should be installed.
- If connecting power to fixed wiring, a switch or circuit breaker that disconnects all poles and has a contact separation of at least 1 /Bin (3mm) must be incorporated in the fixed wiring. The qualified technician must use an approved circuit breaker or switch.
- Only connect the unit to an individual branch circuit outlet. **DO NOT** connect another appliance to that outlet.
- Make sure to correctly earth the air conditioner.
- Every wire **MUST** be firmly connected. Loose wiring can cause the terminal to overheat, resulting in product malfunction and possible fire.
- **DO NOT** let wires touch or rest against refrigerant tubing, the compressor, or any moving parts within the unit.
- If the unit has an auxiliary electric heater, it **MUST** be installed at least 1 metre (40in) away from any combustible materials.
- To avoid getting an electric shock, **NEVER** touch the electrical components soon after the power supply has been turned off. After turning off the power, always wait 10 minutes or more before you touch the electrical components.
- Make sure that you **DO NOT** cross your electrical wiring with your signal wiring. This may cause distortion and interference.
- The unit **MUST** be connected to the main outlet. Normally, the power supply must have a impedance of 32 ohms.
- No other equipment should be connected to the same power circuit.
- Connect the outdoor wires before connecting the indoor wires.



BEFORE PERFORMING ANY ELECTRICAL OR WIRING WORK, TURN OFF THE MAIN POWER TO THE SYSTEM.



The diagrams and schematics are for explanation purpose only. Your machine may be slightly different. The actual shape shall prevail.

Wiring Appliance

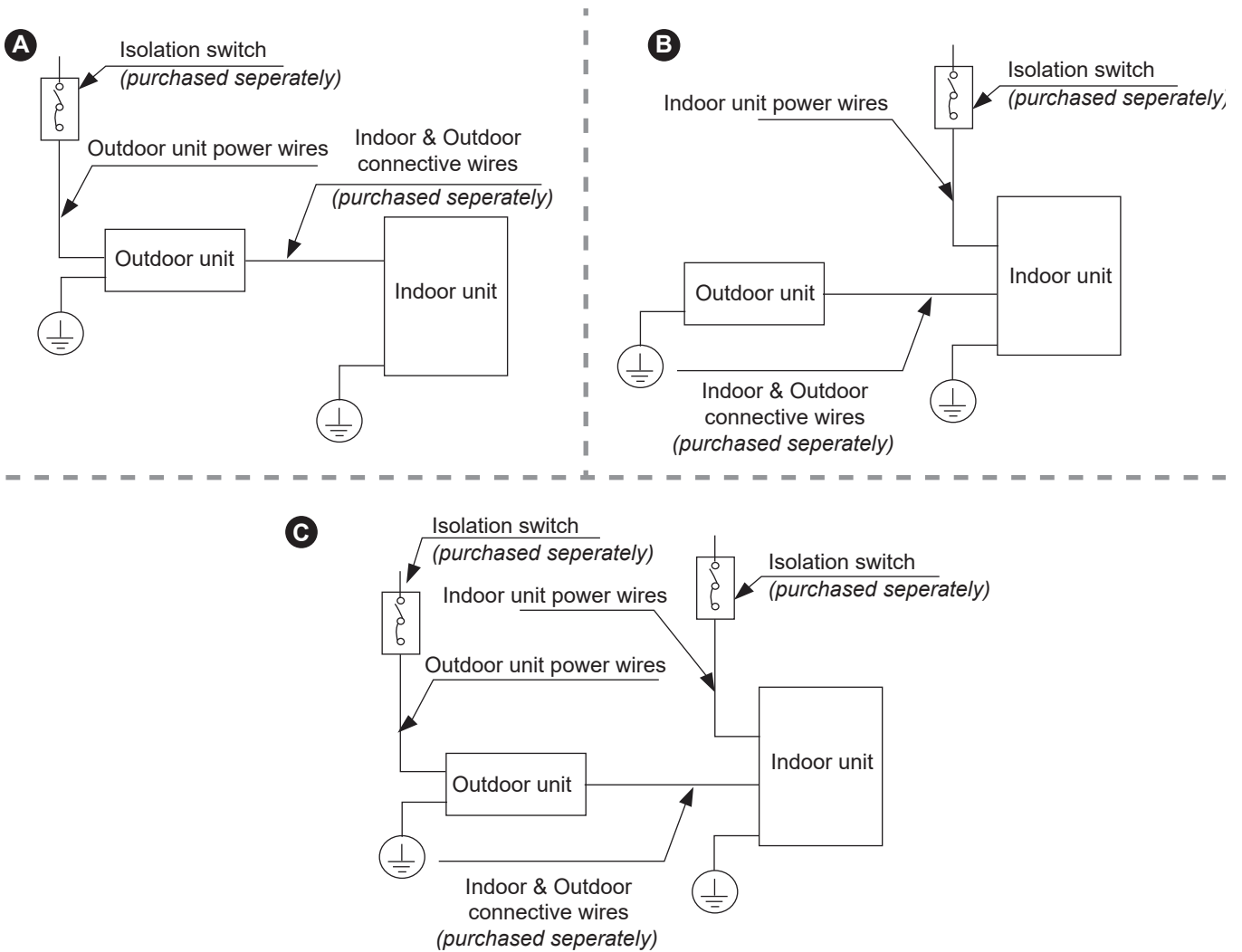

Choose the cable type according to the local electrical codes and regulations.

OUTDOOR UNIT WIRING

1. Prepare the cable for connection following current electrical standards AS/NZS 3000.

Choose the right cable size

The size of the power supply cable, signal cable, fuse, and switch needed is determined by the maximum current of the unit. The maximum current is indicated on the nameplate located on the side panel of the unit. Refer to this nameplate to choose the right cable, fuse, or switch.

- Using wire strippers, strip the rubber jacket from both ends of the signal cable to reveal approximately 15cm of wire.
- Strip the insulation from the ends.
- Using a wire crimper, crimp u-lugs on the ends.



When connecting the wires, strictly follow the wiring diagram found inside the electrical box cover.

WIRING

2. Remove the electric cover of the outdoor unit. If there is no cover on the outdoor unit, take off the bolts from the maintenance board and remove the protection board (see figure below of outdoor unit).

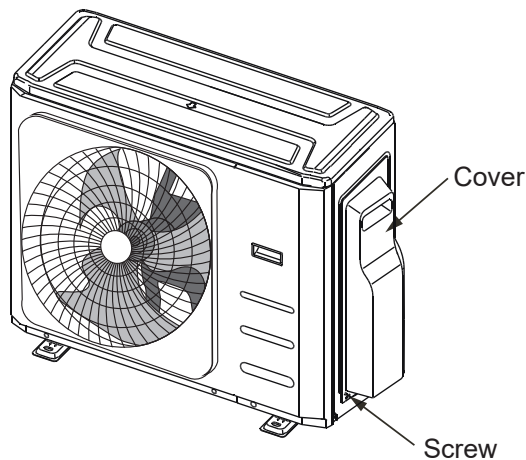

3. Connect the u-lugs to the terminals. Match the wire colours/labels with the labels on the terminal block. Firmly screw the u-lug of each wire to its corresponding terminal.
4. Clamp down the cable with designated cable clamp.
5. Insulate unused wires with electrical tape. Keep them away from any electrical or metal parts.
6. Reinstall the cover of the electric control box. Some models have knock-out panel on the electric cover, it can be cut off to lead out power cords if necessary.

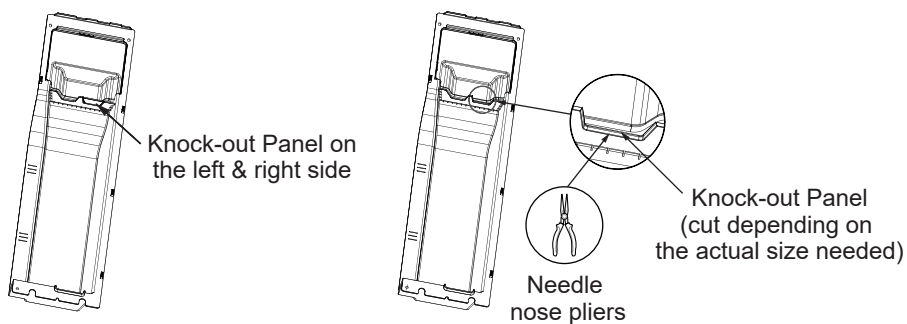

OUTDOOR UNIT WIRING DIAGRAM



Please refer to the following diagrams for the wiring connections for the various models. Please run the main power cord through the lower line-outlet of the cord clamp.

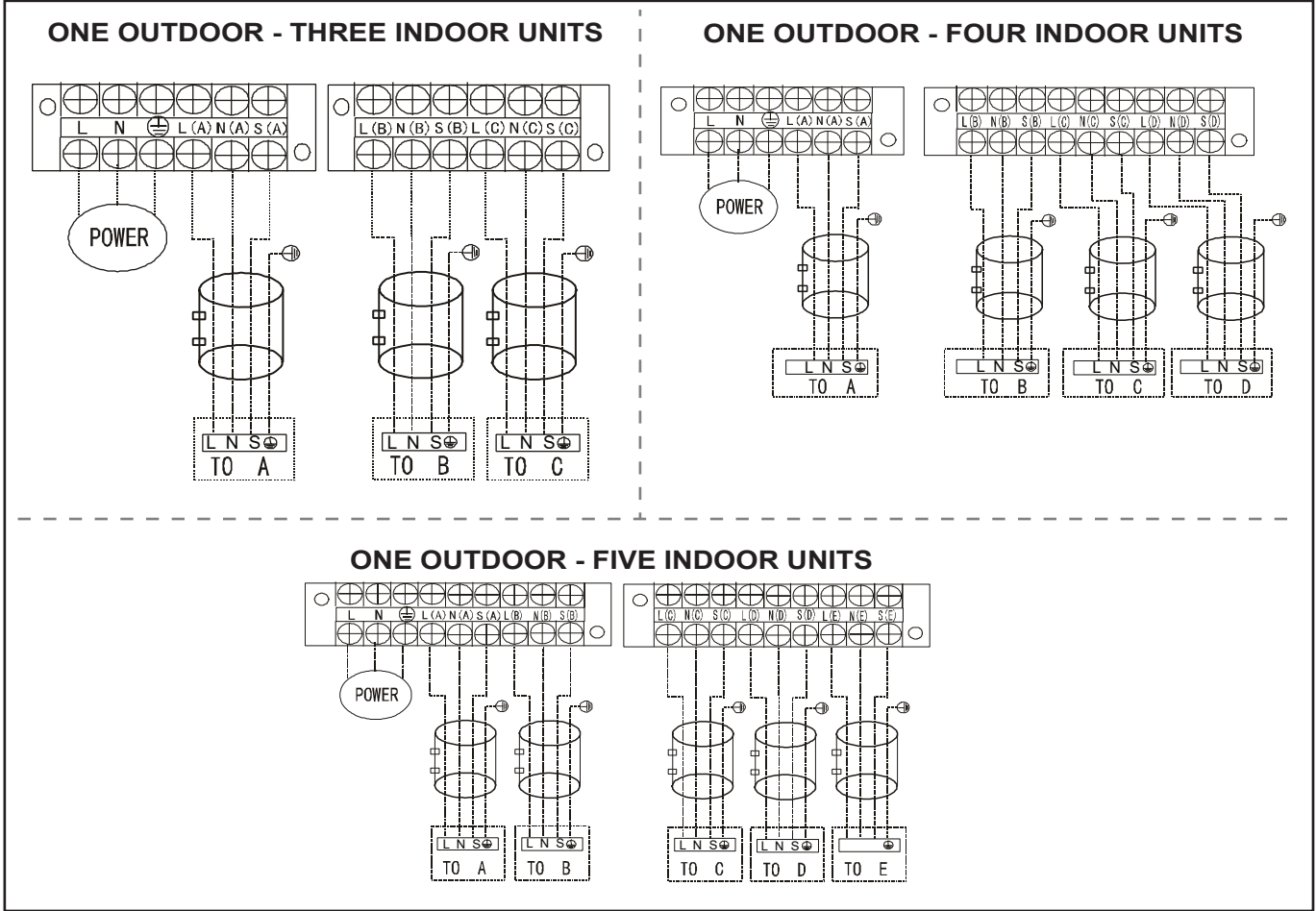

CAUTION

- 1) An individual power circuit must be used for this system.
Wiring shall be conducted in accordance with the unit circuit diagram & these instructions.
- 2) The screws which fasten the wiring within the electrical switchboard may come loose from vibration in transportation. Please ensure that all electrical connections within the unit are sufficiently tightened. Loose connections may cause overheating at the terminals, leading to an electrical failure or malfunction.
- 3) Confirm the suitability of the power source.
- 4) Confirm that electrical capacity is sufficient for the operating current of the system.
- 5) Ensure that the starting voltage is maintained at more than 90 percent of the rated voltage marked as marked on the name plate.
- 6) Confirm that the cable thickness is suitable for the power source specification.
- 7) Always use an adequately sized circuit breaker.
- 8) The issues which may cause voltage drop are for example: vibration/chattering of contractors which will damage the contact points or blown fuses breaking, overload and/or malfunction of the system.
- 9) Before accessing the electrical terminals, disconnect all power from the system.

Compressor / Power Supply Information

Compressor start/stop	Stop time	Min 3 minutes
Power supply voltage	Voltage variance	Within +/- 10% of supply voltage
	Voltage drop	Within +/- 15% of supply voltage
	Voltage imbalance	Within +/- 3% of supply voltage



To satisfy the EMC compulsory regulations, which is required by the standard AS/NZS 61000.6.3, please make sure you apply the correct magnetic rings on your equipment according to the wiring diagram that adheres to your equipment. Please contact your distributor or installer to get further information and purchase magnetic rings (The supplier of magnetic ring is TDK (model ZCAT3035-1330) or similar).

PRESSURE & LEAK TEST

DRY NITROGEN PRESSURE TEST

- Using dry nitrogen, pressure test interconnecting pipework from outdoor unit inclusive of fan coil unit, to the 'Maximum Allowable Pressure' as indicated on the product label of the outdoor unit. For more information, refer to AS/NZS 5149.2.

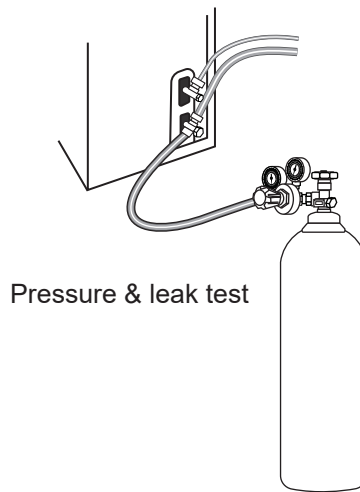

Air, Oxygen, Acetylene or refrigerants shall not be used for pressure testing purposes.

LEAK TESTING INSTRUCTIONS

1. Outdoor unit service ports shall be closed or front seated before commencing.
2. Connect Dry Nitrogen bottle with gauge set to the suction line access point and ensure all fittings are tight.
3. Open the Dry Nitrogen bottle valves and set test pressure to 'Maximum Allowable Pressure' as indicated on the outdoor specification label, **do not exceed**.
4. Use an approved 'Bubble Leak Detector' to assess all joints for leaks, from the outdoor service valves to the connections at the indoor unit.
5. If no leaks are detected close the Dry Nitrogen valves.
6. With care, safely and slowly commence removal of the pressure supply line from the Dry Nitrogen bottle using the bleed to release technique.
7. Once the system pressure has been removed safely you may remove the connecting line from service valve on the appliance.



DO NOT exceed the 'Maximum Allowable Pressure' as this may damage system components which is not covered under warranty.



Wear the correct PPE at all times when working with refrigerants and conducting high pressure tests.

AIR EVACUATION

PREPARATIONS AND PRECAUTIONS

Air and foreign matter in the refrigerant circuit can cause abnormal rises in pressure, which can damage the air conditioner, reduce its efficiency, and cause injury. Use a vacuum pump and manifold gauge to evacuate the refrigerant circuit, removing any non-condensable gas and moisture from the system.

Evacuation **MUST** be performed upon initial installation and when unit is relocated.

Before Performing Evacuation

- Check to make sure the connective pipes between the indoor and outdoor units are connected correctly.
- Check to make sure all wiring is connected correctly.

EVACUATION INSTRUCTIONS

Before using a manifold gauge and a vacuum pump, read their operation manuals to make sure you know how to use them properly.

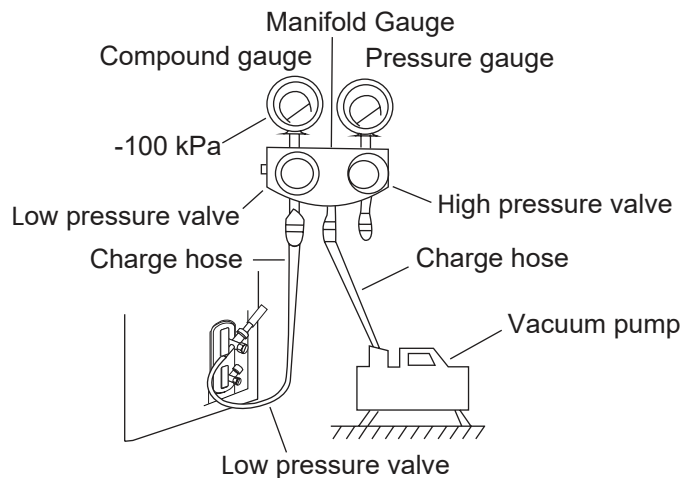

1. Connect the manifold gauge's charge hose to the service port on the outdoor unit's low pressure valve.
2. Connect the manifold gauge's charge hose from the to the vacuum pump.
3. Open the Low Pressure side of the manifold gauge. Keep the High Pressure side closed.
4. Turn on the vacuum pump to evacuate the system.
5. Run the vacuum for at least 30 minutes, or until the Compound Meter reads -100 kPa.
6. Close the manifold gauge's Low Pressure valve and turn off the vacuum pump.
7. Wait for 5 minutes, then check that there has been no change in system pressure..



If there is no change in system pressure, unscrew the cap from the packed valve (high pressure valve). If there is a change in system pressure, there may be a gas leak.

8. Insert hexagonal wrench into the packed valve (high pressure valve) and open the valve by turning the wrench 1/4 counter-clockwise. Listen for gas to exit the system, then close the valve after 5 seconds.

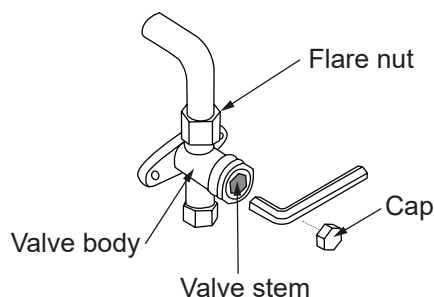

9. Watch the Pressure Gauge for one minute to make sure that there is no change in pressure. It should read slightly higher than the atmospheric pressure.

AIR EVACUATION

10. Remove the charge hose from the service port.
11. Using hexagonal wrench, fully open both the high pressure and low pressure valves.



OPEN VALVE STEMS GENTLY

When opening valve stems, turn the hexagonal wrench anti-clockwise until it hits against the back stop. **DO NOT** try to force the valve to open further.



Check to make sure there is no refrigerant leak after completing the installation work. If there is a refrigerant leak, ventilate the area immediately and evacuate the system.

12. After opening up the service valve stems to allow the refrigerant to flow throughout the system please apply leak search solution to ensure the service valve spindles are not leaking. If service valve spindles are leaking front and back seat them several times to readjust the seal behind the valve stem. Apply Nylog leak lock onto the threaded fittings before service valve caps are placed onto the service valves.
13. Tighten valve caps by hand, then tighten it using the proper tool.
14. If the outdoor unit uses all vacuum valves, and the vacuum position is at the main valve, the system is not connected with the indoor unit. The valve must be tightened with a screw nut. Check for gas leaks before operation to prevent leakage.
15. After removing your refrigeration gauges of the system, please apply leak search solution to ensure the schrader valve cores are not leaking. Apply Nylog leak lock onto the threaded fittings before schrader valve caps are placed onto the service valves ports.

ADDING REFRIGERANT



Refrigerant charging must be performed after wiring, vacuuming, and the leak testing.

DO NOT exceed the maximum allowable quantity of refrigerant or overcharge the system. Doing so can damage the unit or impact it's functioning.

Charging with unsuitable substances may cause explosions or accidents. Ensure that the appropriate refrigerant is used.

Refrigerant containers must be opened slowly. Always use protective gear when charging the system.

DO NOT mix refrigerant types.

For R32 refrigerant model, make sure the conditions within the area have been made safe by control of flammable material when the refrigerant added into the air conditioner

Depending on the length of connective piping or the pressure of the evacuated system, you may need to add refrigerant. Refer to the table below for refrigerant amounts to be added.

Additional Refrigerant per pipe length

Connective Pipe Length (m)	Air Purging Method	Additional Refrigerant (R32)	
Less than Standard pipe length x N	Vacuum Pump	N/A	
More than Standard pipe length x N	Vacuum Pump	Liquid Side: Ø 6.35 (mm) (Total pipe length - pre-charge pipe length x N) x12g/m	Liquid Side: Ø 9.52 (mm) (Total pipe length - pre-charge pipe length x N) x24g/m

N=2 (2 Head models), N=3 (3 Head models), N=4 (4 Head models), N=5 (5 Head models), N=6 (6 Head models).

Make sure to remove the additional refrigerant charge according to the rated volume (7.5m refrigerant piping) when doing market or government verification test.

Example 1:

	Liquid size (mm)	Actual length (m)	Pre-charged length (m)	Charge adjustment (g)	Total adjustment (g)
UNIT 1	6.35	10	10x4=40	$(10+9+16+8-40) \times 12 = 3 \times 12 = 36$	36+96=132
UNIT 2	6.35	9			
UNIT 3	6.35	16			
UNIT 4	6.35	8			
UNIT 5	9.52	12	10x2=20	$(12+12-20) \times 24 = 4 \times 24 = 96$	
UNIT 6	9.52	12			

Example 2.

	Liquid size (mm)	Actual length (m)	Pre-charged length (m)	Charge adjustment (g)	Total adjustment (g)
UNIT 1	6.35	7	10x4=40	$(7+8+9+5-40) \times 12 = -11 \times 12 = -132$	-132+240=108
UNIT 2	6.35	8			
UNIT 3	6.35	9			
UNIT 4	6.35	5			
UNIT 5	9.52	15	10x2=20	$(15+15-20) \times 24 = 10 \times 24 = 240$	
UNIT 6	9.52	15			

Example 3.

	Liquid size (mm)	Actual length (m)	Pre-charged length (m)	Charge adjustment (g)	Total adjustment (g)
UNIT 1	6.35	12	10x4=40	$(12+15+15+12-40) \times 12 = 14 \times 12 = 168$	168-240=-72 (Note: do not remove any refrigerant)
UNIT 2	6.35	15			
UNIT 3	6.35	15			
UNIT 4	6.35	12			
UNIT 5	9.52	5	10x2=20	$(5+5-20) \times 24 = -10 \times 24 = -240$	
UNIT 6	9.52	5			



The standard pipe length is 10m.



If the total adjustment is negative, there is no need to remove any refrigerant, additional refrigerant is only required if the final calculation is positive.

SAFETY AND LEAKAGE CHECK

Electrical safety check

Perform the electrical safety check after completing installation. Covering the following areas:

1. **Insulated resistance**
The insulated resistance must be more than 2 Ohm.
2. **Earthing work**
After finishing earthing work, measure the earthing resistance by visual detection and using the earthing resistance tester.
Make sure the earthing resistance is less than 4 Ohm.
3. **Electrical leakage check** (performing during test while unit is on).
During a test operation after completed installation, the use the electro-probe and multimeter to perform an electrical leakage check. Turn off the unit immediately if leakage happens. Try and evacuate different solutions until the unit operates properly.

Gas leak check

1. **Soap water method**
Apply a soap-water solution or a liquid neutral detergent on the indoor unit connection or outdoor unit connections with a soft brush to check for leakage of the connecting points of the piping. If bubbles emerge, the pipes are experiencing leakage.
2. **Leak detector**
Use the leak detector to check for leakage.

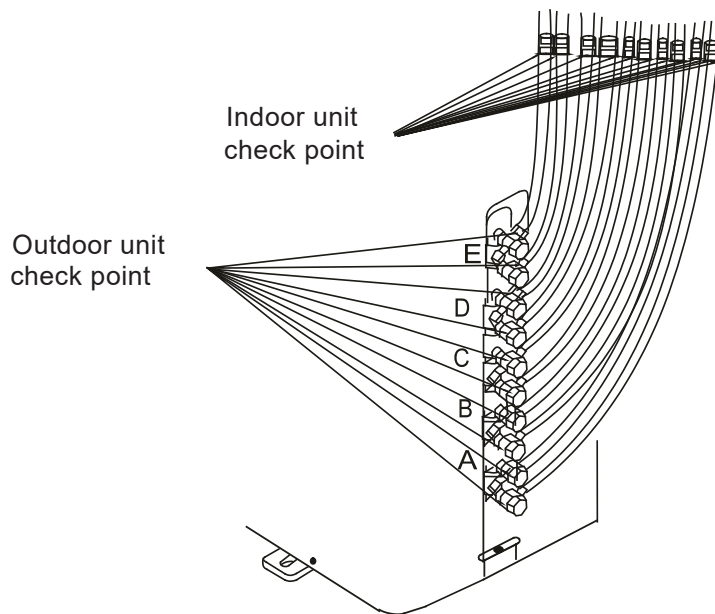

A, B, C, D are points for the 4 head model
A, B, C, D and E are points for the 5 head model



The illustration is an example only. The actual order of A, B, C, D, and E on the model may be slightly different from the unit you purchased but the general shape will remain the same.

BEFORE TEST RUN

A test run must be performed after the entire system has been completely installed. Confirm the following points before performing the test:

- a) Indoor and outdoor units are properly installed.
- b) Piping and wiring are properly connected.
- c) No obstacles near the inlet and outlet of the unit that might cause poor performance or product malfunction.
- d) Refrigeration system does not leak.
- e) Drainage system is unimpeded and draining to a safe location.
- f) Heating insulation is properly installed.
- g) Earthing wires are properly connected.
- h) Length of the piping and additional refrigerant stow capacity have been recorded.
- i) Power voltage is the correct voltage for the air conditioner.



Failure to perform the test run may result in unit damage, property damage, or personal injury.

TEST RUN INSTRUCTIONS

1. Ensure both the liquid and gas stop valves are open.
2. Turn on the main power switch and allow the unit to warm up.
3. Set the air conditioner to COOL mode.
4. **For the Indoor Unit**
 - a) Ensure the remote controller buttons work properly.
 - b) Ensure the louvers move properly and can be changed using the remote control.
 - c) Double check to see if the room temperature is being registered correctly.
 - d) Ensure the indicators on the remote controller and the display panel on the indoor unit work properly.
 - e) Ensure the manual buttons on the indoor unit works properly.
 - f) Check to see that the drainage system is unimpeded and draining smoothly.
 - g) Ensure there is no vibration or abnormal noise during operation.
5. **For the Outdoor Unit**
 - a) Check to see if the refrigeration system is leaking.
 - b) Make sure there is no vibration or abnormal noise during operation.
 - c) Ensure the wind, noise, and water generated by the unit do not disturb your neighbours or pose a safety hazard.



If the unit malfunctions or does not operate according to your expectations, please refer to the Troubleshooting section of the Owner's Manual before calling customer service.

AUTOMATIC CORRECTION FUNCTION

AUTOMATIC WIRING/PIPING CORRECTION FUNCTION

More recent models now feature automatic correction of wiring/piping errors. Press the “check switch” on the outdoor unit PCB board for 5 seconds until the LED displays “CE”, indicating that this function is working. Approximately 5-10 minutes after the switch is pressed, the “CE” disappears, meaning that the wiring/piping error is corrected and all wiring/piping is properly connected.

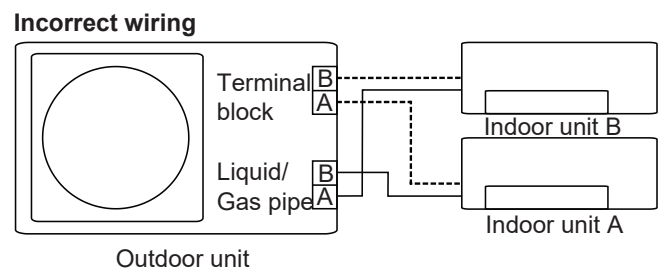
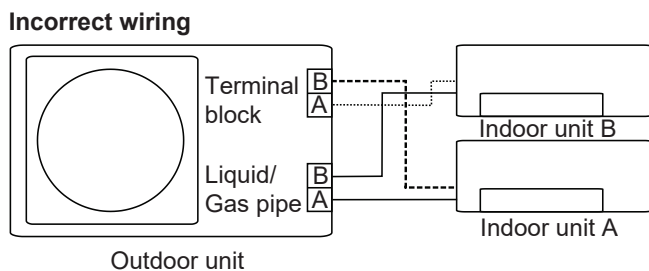
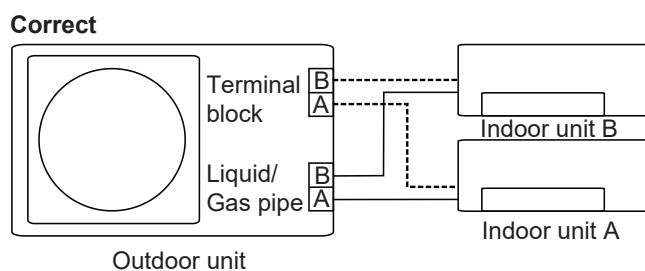
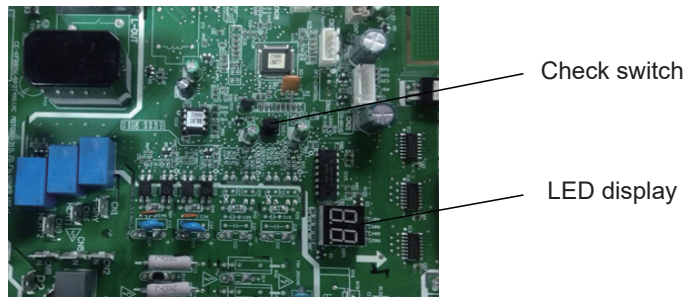

How To Activate This Function

1. Check that outside temperature is above 5°C.
(This function does not work when outside temperature is not above 5°C)
2. Check that the stop valves of the liquid pipe and gas pipe are open.
3. Turn on the breaker and wait at least 2 minutes.
4. Press the check switch on the outdoor PCB board unit LED display “CE”.

COMMISSIONING

COMMISSIONING CHECKLIST

Installer to please complete all sections of this form.

System Information

Model (Outdoor Unit)		Serial No. (Outdoor Unit)	
Model (Indoor Unit)		Serial No. (Indoor Unit)	
Model		Serial No.	
Installed by / Date			

Pre Start-Up

(Please tick boxes below as each item is completed).

<input type="checkbox"/>	Verify that all packaging materials have been removed from the unit.
<input type="checkbox"/>	Remove all shipping hold down bolts and brackets, as per installation instructions.
<input type="checkbox"/>	Check that condensate connection is installed, as per installation instructions.
<input type="checkbox"/>	Check all electrical connections and terminals for tightness.
<input type="checkbox"/>	Check that indoor return air filter is clean and in place.
<input type="checkbox"/>	Verify that unit installation is level.
<input type="checkbox"/>	Check fans for alignment and noise

Operation Characteristics

(Please record the following data after at least 20 minutes running time).

Suction Pressure	kPa
Suction Line Temperature	°C
Discharge Pressure	kPa
Liquid Line Temperature	°C
Superheat	K
Sub-Cooling	K
Compressor Amps (L1)	A
Compressor Amps (L2 for 3 phase)	A
Compressor Amps (L3 for 3 phase)	A
Indoor Coil Air On (Return) Temperature	°C DB
Indoor Coil Air On (Supply) Temperature	°C DB
Outdoor Air Temperature (Ambient)	°C DB
Length of Liquid Line	m
Length of Suction Line	m
Liquid Line Diameter	mm
Suction Line Diameter	mm
Extra refrigerant quantity charged (if any)	kg
Supply Voltage	V
Actual Voltage	V

Rinnai Australia Pty Ltd

ABN 74 005 138 769 | AU45204

82-88 Mills Road, Braeside, Victoria, 3195
P.O. Box 460, Braeside, Victoria, 3195
Tel: (03) 9271 6625

Customer Support

Tel: 1300 555 545*

Monday to Friday, 8.00 am to 5.00 pm EST.

**Cost of a local call may be higher from a mobile phone.
(National calls from public phones in Australia are free.)*

For further information visit **www.rinnai.com.au**
or email **enquiry@rinnai.com.au**

Rinnai has a Service and Spare Parts network with personnel who are fully trained and equipped to give the best service on your Rinnai appliance. If your appliance requires service, please call Customer Support. Rinnai recommends that this appliance be serviced once a year.

With our policy of continuous improvement, we reserve the right to change, or discontinue at any time, specifications or designs without notice.