

MODELS

System	Outdoor	Indoor
7	DONSR07B1LA	DINLR07B1A
9	DONSR09B1LA	DINLR09B1A
11	DONSR11B1LA	DINLR11B1A
13	DONSR13B1LA	DINLR13B1A
15	DONSR15B1LA	DINLR15B1SA
	DONSR15B1TA	DINLR15B1SA
18	DONSR18B1TA	DINLR18B1SA

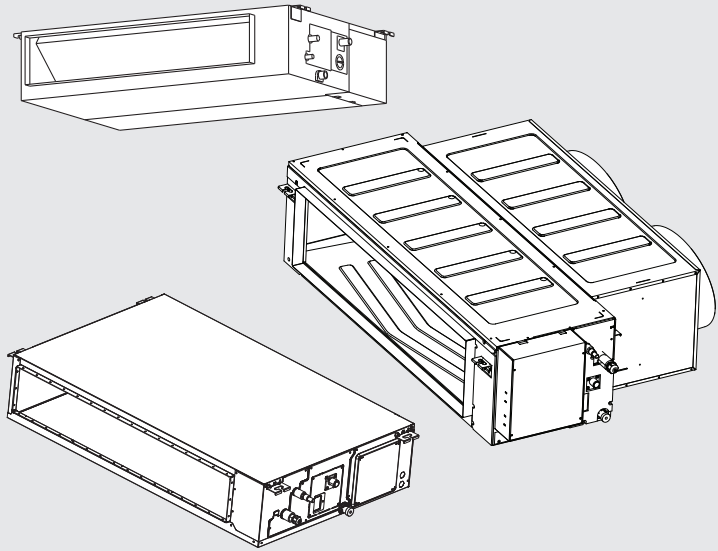
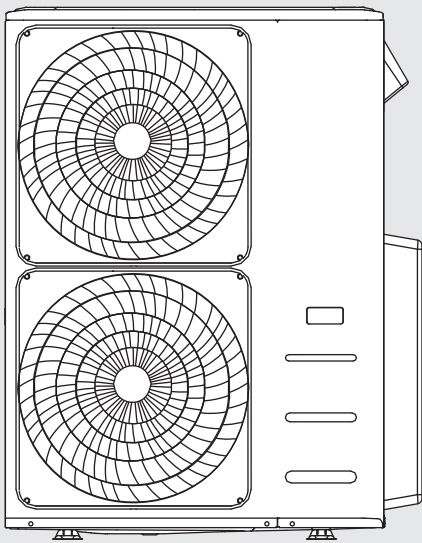

Ducted Reverse Cycle Inverter

Operation Manual

Rinnai



Read this manual and **SAFETY MANUAL** carefully before installing or operating your new air conditioning unit. Make sure to save this manual for future reference.

Please check the applicable models, technical data and manufacturer's information from the "Operation Manual" in the packaging of the outdoor unit.

This appliance must be installed in accordance with:

- Manufacturer's Installation Instructions
- Current AS/NZS 3000, AS/NZS 5149, AS/NZS 5141
- Local Regulations including local OH&S requirements, and Municipal Building Codes, including the National Construction Code (NCC).

This appliance must be installed, maintained and removed only by an Authorised Person. Rinnai recommends that this appliance be serviced once a year.

For continued safety of this appliance it must be installed and maintained in accordance with the manufacturer's instructions.



The design and specifications are subject to change without prior notice for product improvement. Consult with the Dealer or manufacturer for details.

Any updates to the manual will be uploaded to the website. Please check for the latest version.



PLEASE REFER TO ANY OPERATING MANUALS AND USER OPERATING GUIDES ACCOMPANYING ANCILLARY EQUIPMENT (WHERE FITTED)

TABLE OF CONTENTS

Warnings and Important Information	4
Safety Precautions	5
Disposal Guidelines	8
General User Guide	9
Operation and Maintenance	9
Operating your system	9
Cooling Cycle	10
Heating Cycle	10
Zoned Systems	10
Performing Routine Maintenance	10
Checking The Air Filter	11
Unit Support	11
Non-Rinnai Field Supplied Accessories	11
Operation	12
Unit Specifications & Features	12
Operating Temperature	12
Inverter Split Type	12
Care & Maintenance	13
Cleaning the Air Filter	13
Cleaning the Outdoor Unit	13
General Maintenance	13
Maintenance - Pre-Season Inspection	13
Installation Record - Installer Details	14
Installation Record - System Details	14
Customer care Program	14
Service Maintenance Schedule - Ducted Air Conditioning Systems	15
Save A Service Call	16
Troubleshooting	18
Troubleshooting Tips	18
When to Call for Service	19
Contacts	24



Scan QR to register your warranty

WARNINGS AND IMPORTANT INFORMATION



READ ALL INSTRUCTIONS BEFORE USING THE APPLIANCE.

Always comply with the following precautions to avoid dangerous situations and to ensure optimum performance.

Failure to carefully read and follow all instructions in this manual can result in equipment malfunction, property damage, personal injury and/or death.

WARNINGS: WHEN IGNORED, CAN RESULT IN SERIOUS INJURY OR DEATH.

CAUTIONS: WHEN IGNORED, CAN RESULT IN MINOR INJURY OR PRODUCT DAMAGE.



REGULATORY / INSTALLATION

This appliance shall be installed in accordance with:

- Manufacturer's Installation Instructions.
- Current AS/NZS 3000, AS/NZS 5141, AS/NZS 5149, AS/NZS 3500 National Plumbing & Drainage, HB276 - A Guide to good practice for energy efficient installation.
- Local regulations, including local OH&S requirements, and Municipal Building Codes, including the National Construction Code (NCC).
- This appliance must be installed, maintained and removed by an Authorised Person.

For continued safety of this appliance it must be installed and maintained in accordance with the manufacturers instructions.

This appliance uses R32 refrigerant.

This appliance is heavy, use 2 people or mechanical lifting device. Improper lifting may result in serious injury.

Take care when opening or unpacking this appliance. Failure to do so may result in serious injury or product failure.

DO NOT modify the electrical wiring of this appliance. If the control power wiring is damaged or deteriorated then it must be replaced by an authorised person. Failure to do so may result in electric shock, fire, serious injury or product failure.

DO NOT install the air conditioner on an unstable or non level surface or where there may be a danger of it falling. It may result in death, serious injury, or product failure.

DO NOT install the outdoor unit where noise may cause nuisance.

DO NOT install the outdoor unit where it will be exposed to sea wind (salt spray) as this will reduce durability.

ACHIEVING OPTIMAL PERFORMANCE

For optimal performance ensure to use the air conditioner within the following temperature ranges. Using the air conditioner outside of these ranges, will activate certain safety protection features, that will effect the appliances performance.

MODE	COOL MODE	HEAT MODE
Room Temperature	16°C ~ 32°C	0°C ~ 30°C
Outdoor Temperature	-15°C ~ 50°C	-20°C ~ 24°C

WARRANTY EXCLUSIONS

Rinnai product warranty excludes faults and failures caused by improper use and abuse; fair wear and tear; or failure to follow instructions regarding service and maintenance. It is very important that you maintain your appliance and have it serviced regularly. It is a condition of warranty that you adhere to the maintenance and service requirements as set out in this manual. Compliance with these requirements will prolong the useful life of your appliance and help ensure it operates efficiently. The "Service Maintenance Schedule - Ducted Air Conditioning Systems" on page 15 specifies specific items to be performed at prescribed intervals by qualified licensed technicians. The schedule should also be fully completed and retained as a record of who carried out the service, the date and actions taken.

IMPORTANT: Failure to carry out the requisite maintenance, servicing and recording requirements may void your product warranty. Please refer to "Warranty" on page 20 for full details.



WARNINGS FOR PRODUCT USE

- If an abnormal situation arises (like a burning smell), immediately turn off the unit and isolate power. Call your dealer for instructions to avoid electric shock, fire or injury.
- **DO NOT** insert fingers, rods or other objects into the air inlet or outlet. This may cause injury, since the fan may be rotating at high speeds.
- **DO NOT** use flammable sprays such as hair spray, lacquer or paint near the unit. This may cause fire or combustion.
- **DO NOT** operate the air conditioner in places near or around combustible gases. Emitted gas may collect around the unit and cause explosion.
- **DO NOT** operate your air conditioner in a wet room such as a bathroom or laundry room. Too much exposure to water can cause electrical components to short circuit.
- **DO NOT** expose your body directly to cool air for a prolonged period of time.
- **DO NOT** allow children to play with the air conditioner. Children must be supervised around the unit at all times.
- If the air conditioner is used together with burners or other heating devices, thoroughly ventilate the room to avoid oxygen deficiency.
- In certain functional environments, such as kitchens, server rooms, etc., the use of specially designed air-conditioning units is highly recommended.



ELECTRICAL WARNINGS

- Keep power isolator clean. Remove any dust or grime that accumulates on or around the plug. Dirty plugs can cause fire or electric shock.
- The product must be properly earthed at the time of installation, or electrical shock may occur.
- For all electrical work, follow all local and national wiring standards, regulations, and the Installation Manual. Connect cables tightly, and clamp them securely to prevent external forces from damaging the terminal. Improper electrical connections can overheat and cause fire, and may also cause shock. All electrical connections must be made according to the Electrical Connection Diagram located on the panels of the indoor and outdoor units.
- All wiring **MUST** be properly arranged to ensure that the control board cover can close properly. If the control board cover is not closed properly, it can lead to corrosion and cause the connection points on the terminal to heat up, catch fire, or cause electrical shock.
- If connecting power to fixed wiring, an all-pole disconnection device which has at least 3mm clearances in all poles, and have a leakage current that may exceed 10mA, the residual current device (RCD) having a rated residual operating current not exceeding 30mA, and disconnection must be incorporated in the fixed wiring in accordance with the wiring regulations.

SAFETY PRECAUTIONS



PRODUCT INSTALLATION WARNINGS

- Installation must be performed by an authorised dealer or specialist. Defective installation can cause water leakage, electrical shock, or fire.
- Installation must be performed according to the installation instructions and installed by an Authorised Person only. Improper installation can cause water leakage, electrical shock, or fire.
- Contact an authorised service technician for repair or maintenance of this unit. This appliance shall be installed in accordance with current wiring regulations.
- The indoor unit shall not be installed under a floor or beneath a deck, to be installed in a roof space only.



FLUORINATED GASES

- This air-conditioning unit contains fluorinated refrigerant gases. For specific information on the type of gas and the amount, please refer to the relevant label on the unit itself or the “Owner’s Manual” in the packaging of the outdoor unit.
- Installation, service, maintenance and repair of this unit must be performed by a certified technician.
- Product decommissioning and recycling must be performed by a certified technician.
- When the unit is checked for leaks, proper record-keeping of all checks is strongly recommended.



Certain types of refrigerant (Including R32) require minimum room sizes. Please ensure that these minimum room sizes are adhered to for standard installations (up to pre-charged pipe lengths). If larger refrigerant charges than standard are used, then consult AS/NZS 60335.2.40 to determine the safe minimum floor area for the installation.



CLEANING AND MAINTENANCE WARNINGS

- Turn main power off before cleaning. Failure to do so may result in fire, electric shock, or product failure.
- **DO NOT** clean the air conditioner with excessive amounts of water.
- **DO NOT** clean the air conditioner with combustible cleaning agents. Combustible cleaning agents can cause fire or deformation.
- **DO NOT** use solvents, abrasives or harsh detergent to clean any part or surface of this appliance or spray water or allow liquids to enter the indoor unit. The enclosure of the appliance and control can be cleaned using a soft, damp cloth and a mild detergent.



- Turn off the air conditioner and isolate the power if you are not going to use it for a long time.
- Make sure that water condensation can drain unhindered from the unit.
- **DO NOT** use device for any other purpose than its intended use.
- **DO NOT** climb onto or place objects on top of the outdoor unit.



MANDATORY INSPECTION PRIOR TO INSTALLATION

Immediately report any damage or discrepancies to the Supplier of the appliance. This appliance was inspected and tested at the time of manufacture and packaging, and released for transportation without known damage. Upon receipt, inspect the exterior for evidence of rough handling in shipment. Ensure that the appliance is labelled correctly for the gas and electrical supply, and/or other services it is intended to be connected to.

For safety and warranty purposes, appliances that may be damaged or incorrect **MUST NOT** be installed or operated under any circumstances. Installation of damaged or incorrect appliances may contravene local government regulations. Rinnai disclaims any liability or responsibility whatsoever in relation to the installation or operation of damaged or incorrect appliances.



A NOTE ON ILLUSTRATIONS

The illustrations used in this manual are for explanatory purposes only and the shape of your indoor unit may vary slightly from that which is shown in this manual.



USING R32 REFRIGERANT

When flammable refrigerants are employed, appliance shall be located in a well-ventilated area where the room size corresponds to the room area as specified for operation.



OPERATION

DO NOT let the air conditioner run for extended periods when the humidity is very high or when doors or windows are left open. As this may result in an excessive operational loading and lead to product failure.

DO NOT cover or place articles on any part of this appliance.

DO NOT touch, operate or clean the air conditioner with wet hands. It may result in electric shock or product failure.

DO NOT insert hands or other objects through the air inlet or outlet of the appliance it may result in electric shock or product failure.

DO NOT place a heater or other heating appliances near this appliance, always ensure sufficient ventilation when using this appliance and a heating appliance at the same time. Failure to do so may result in product miss-operation.

DO NOT leave flammable materials near the appliance. It may result in explosion or fire.

If there is excessive noise, smell or smoke coming from the appliance, turn the appliance off, isolate the power supply and contact Rinnai.

DO NOT operate the appliance if it has been submerged into water due to flooding, contact a service agent. Failure to do so may result in electric shock, fire, serious injury, or product failure.

This appliance is not intended for use by persons (including children) with reduced physical, sensory or mental capabilities, or lack of experience and knowledge unless they have been given supervision or instruction concerning use of the appliance by a person responsible for their safety.

Children should be supervised to ensure that they do not play with the appliance.

The air conditioning system is designed to achieve consumer comfort. It is not designed for commercial applications requiring a controlled atmosphere (i.e. computer rooms, food preservation, etc.)

DO NOT block the inlet or outlet of air flow. It may result product failure.

DO NOT drink the condensate water drained from the appliance. This condensate is not potable and may present a health risk if consumed.

DO NOT expose people, animals or plants directly to the cold or hot discharge of the appliance. It may result in serious injury.



REFRIGERANT

This appliance uses R32 (difluoromethane) refrigerant, which is a flammable gas class A2L according to AS 5149.1 and must be handled by a refrigeration mechanic with an appropriate Australian refrigerant handling licence.



WARNING Risk of fire / flammable material. If the refrigerant is leaked, together with an external ignition source, there is a possibility of ignition.



Read the **OPERATING INSTRUCTIONS** carefully before operation.



Service personnel are required to carefully read the **OPERATING INSTRUCTIONS** and **INSTALLATION MANUAL** before operation.



Further information is available in the **OPERATING INSTRUCTIONS**, **INSTALLATION MANUAL**, and the like.

Certain levels of refrigerant require minimum room sizes. Please ensure that these minimum room sizes are adhered to for standard installations (up to 15m pipe length). If larger refrigerant charges than standard are used then please consult AS/NZS 60335.2.40 to determine the safe minimum floor area for the installation.

Make sure that the area has been made safe by having suitable ventilation and is free from ignition sources before charging or releasing the charge of R32.

Model	DONSR07B1LA	DONSR09B1LA	DONSR11B1LA	DONSR13B1LA	DONSR15B1LA	DONSR15B1TA	DONSR18B1TA
Standard Charge (g)	1500	2600	2600	3500	3500	3600	3800
Minimum Floor Area (m ²)	1.42	4.28	4.28	7.75	7.75	8.20	9.14

- All minimum room sizes in the above table are calculated on the base charge provided with the outdoor unit.
- Mechanical connectors used indoors shall comply with ISO 14903.
- This appliance shall be installed in accordance with AS/NZS 5149.
- When mechanical connectors are reused, sealing parts shall be renewed.
- When flared joints are reused, the flare part shall be re-fabricated.

DISPOSAL GUIDELINES

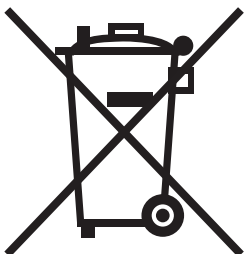

This appliance contains refrigerant and other potentially hazardous materials. When disposing of this appliance, the law requires special collection and treatment. **DO NOT** dispose of this product as household waste or unsorted municipal waste.



Special notice – Disposing of this appliance in the forest or other natural surroundings endangers your health and is bad for the environment. Hazardous substances may leak into the ground water and enter the food chain.

OPERATION AND MAINTENANCE

Welcome to high efficiency year-round comfort.

Congratulations on your excellent choice and sound investment in a Rinnai Ducted Reverse Cycle Inverter Home Comfort System. Please also take the time to read the contents of this Operating Manual, register your product warranty and retain this document for future reference.

Your new Rinnai system represents both the latest in engineering developments and the culmination of many years of experience by one of the most reputable manufacturers of home comfort systems.

Your new unit is among the most reliable home comfort products available today. To achieve the performance and efficiency expected from your new system, please ensure the Installer is a qualified tradesperson, that the Installer has commissioned the unit and instructed you on its operation.

To assure its dependability, learn about the operation of your system and the small amount of maintenance it takes to keep it operating at its peak efficiency. With minimal care, your Rinnai system will provide you and your family with satisfying home comfort - both now and for many years to come.



Improper installation, adjustment, alteration, service, maintenance, or use, can cause explosion, fire, electric shock, or other conditions which may cause personal injury or property damage. Refer to this document or and or other accompanying manuals.

For assistance or additional information consult Rinnai, a qualified installer or authorised service agency. The qualified installer or agency should use only factory authorised components or accessories if and when servicing this product.

To better protect your investment and to eliminate unnecessary service calls, please familiarise yourself with the following:

- Your ducted system should never be operated without a clean filter properly installed. Plan to inspect the filter periodically. A clogged filter will increase operating costs and shorten the life of the unit. Supply-air and return-air registers (grilles) should not be blocked or obstructed. Restricted airflow lessens the unit's efficiency and life span.
- Outdoor (condenser / compressor) units must have unrestricted airflow. Do not cover the unit, lean any thing against it, or stand upon it. Do not allow grass clippings, leaves, or other debris to accumulate around or on top of the unit. Maintain a minimum of 300mm clearance between the outdoor unit and tall grass, shrubs, vines etc.
- Your Thermostat / Controller is the control centre for your system. Please familiarise yourself with its specific operation, as the information following is of a general nature.
- Attempting to control the system by other means - for instance, switching the electrical supply power ON and OFF, may cause damage to the unit.
- Thermostat 'jiggling' causes rapid-cycling, which is potentially dangerous to the compressor and may blow the protective fuse or circuit breaker device at the mains power supply. Do not adjust the temperature on the thermostat for any reason for at least five (5) minutes after the compressor has shut off.
- You may find that you can maintain greater personal comfort by running the FAN continuously. 'Air pockets' can form due to the structure of the building, placement of registers etc. These air pockets may create cool or warm spots. Continuous FAN operation helps minimise any temperature differences.
- Systems equipped with electronic air cleaners or humidifiers accessories offer the added benefit of having the air continuously cleaned year round, and humidified during the winter season.
- Your system removes humidity from your home during the cooling season. The Indoor unit has a (primary) condensate connected to your drainage system; but an overflow (secondary) drain should also be installed. If water is observed in the overflow drain - it may be clogged, and your installer or Rinnai should be contacted for inspection.

OPERATING YOUR SYSTEM

The operation of your systems is controlled by the indoor Thermostat / Controller. Simply adjust the Controller to maintain the indoor temperature at the level you select, subject to it being within the design conditions of the system. Typical settings are 24°C and 20°C for Cooling and Heating respectively.

The Rinnai Inverter System will automatically modulate the outdoor unit capacity in response to the demand of the conditioned space, to help ensure rapid cool down or warm up times, as well as providing more constant temperature control. Please refer to the Operating Instructions accompanying your Thermostat / Controller.

COOLING CYCLE

When operating in the COOL mode, your system will run until the indoor temperature is lowered to the level you have selected (within design conditions). On extremely hot days, your system will run for longer periods at a time and have shorter 'off' periods than on moderate days.

The following typical conditions add extra heat and/or humidity to your home causing your system to work longer to maintain comfortable conditions:

Entrance (external) doors are frequently opened & closed.	More than the usual number of people.
Operating laundry appliances or running showers.	Window furnishings open on sunny side of home.
More than the usual lights or electrical appliances operating.	System operating at or outside the original system design conditions as specified by your Installer

HEATING CYCLE

In HEAT mode, the system will provide warmth until the temperature is raised to the level you have selected. The unit will operate for longer periods to maintain a comfortable environment on colder days and nights than on moderate ones.

Defrost Cycle: When the system provides heating to your home and the outdoor temperature drops below 7.2°C, moisture may begin to freeze on the surface of the outdoor coil. If allowed to build up, this ice would impede the airflow across the coil and reduce the amount of heat absorbed from the outside air. To maintain energy efficient operation, your Rinnai Heat Pump has an automatic defrost cycle.

The defrost controls will automatically start when there is sufficient ice to interfere with normal heating operation. During defrost, the Indoor Fan will not be running. After the ice is melted, or after a maximum of 10 minutes in defrost mode, the unit will automatically resume normal heating operation.

Do not be alarmed if steam or fog appears at the Outdoor Unit during the defrost cycle. Water vapour from the melting ice may condense into a mist in the cold outdoor air.

ZONED SYSTEMS

Some home comfort systems are designed to operate on a zoned basis only – i.e. they are not designed to heat and or cool the entire home or space at one time. Generally, a zoned system will be designed by your Installer for your specific requirements. Your particular zoning configuration and the basis of design should be specified and detailed by your Installer. With zoned systems, always observe the following:

- The Return Air grille(s) are generally in the 'Common Zone', and need to be part of the conditioned space at all times.
- Close off all doors to areas that are not being conditioned – i.e. effectively isolate unconditioned spaces.
- Set your zoning configuration with your zone controls before starting your Rinnai system.
- Do not attempt to shut down more zones than the minimum as specified by your installer, as this may lead to system shut down.
- Do not attempt to heat or cool more zones than the maximum specified by your installer as this will prevent the system from being able to maintain design conditions. NOTE: The type of zoned system you have will have been specified by your installer. This should include information on the total number of zones, the minimum and maximum number recommended to operate at one time to maintain design conditions, and the actual design conditions (Indoor Temperature Control settings at specified Outdoor Ambient conditions for both Heating and Cooling).

PERFORMING ROUTINE MAINTENANCE

With proper maintenance and care, your Rinnai system will operate economically and dependably.

Maintenance can be accomplished easily by referring to the following general directions. However, before performing maintenance, consider these important safety precautions:

- DISCONNECT ALL ELECTRICAL POWER TO HEAT PUMP BEFORE REMOVING ACCESS PANELS TO PERFORM SERVICE OR MAINTENANCE – NOTE: THERE MAY BE MORE THAN ONE ELECTRICAL ISOLATING SWITCH
- ALTHOUGH SPECIAL CARE HAS BEEN TAKEN TO MINIMISE SHARP EDGES IN THE CONSTRUCTION OF YOUR UNIT, BE EXTREMELY CAREFUL WHEN HANDLING PARTS OR REACHING INTO THE UNIT.

CHECKING THE AIR FILTER

- Filters are supplied and fitted by your installer and are not part of the Rinnai system. A dirty air filter will cause excessive strain on the compressor and fan blower motor. This can cause the compressor to overheat and automatically shut down. In the extreme, the components will fail and will need to be replaced.
- To avoid inefficient or failed operation of your unit, CHECK THE FILTER AT LEAST EVERY 2 TO 4 WEEKS.
- Replace filter(s) when necessary, or clean them if they are the reusable type. Disposable filters should be replaced by similar, new filters of the same grade and dimensions.
- Reusable (permanent) type filters should be washed in a solution of cold to tepid water and very mild detergent, then rinsed and thoroughly dried. THE FILTER MUST BE COMPLETELY DRY BEFORE BEING REPLACED.
- To avoid prolonged shutdown of your system while a filter is being cleaned, you may wish to have an extra filter on hand. This would allow you to rotate between the two with minimal downtime for your comfort system. Extra filters are available from your Installer or a Rinnai Spare Parts outlets.
- Should you have any questions about the removal and/or cleaning of you filter(s), please contact your Installer for assistance.
- If grass clippings, leaves, shrubbery and debris are kept away from the Outdoor Unit, minimal care should be sufficient to keep the system functioning properly. However, if the outdoor coil becomes dirty, use a soft brush or vacuum and soft brush attachment to clean the exterior surface. If dirt is trapped deep within the coil, contact your Installer or Rinnai for service.

UNIT SUPPORT

- The indoor Fan Coil Unit (FCU) should be located in a position and in such a manner as specified in the Installation Instructions. The FCU should be maintained at a position that ensures condensate drainage from the unit. In an attic space, ideally the unit will be easily and safely accessible from the ceiling access panel, have a suitable catwalk and platform, and if necessary a service light.
- The outdoor Condensing Unit (CDU) requires adequate support to ensure it is level. CDUs generate condensate water in the heating mode; depending on local codes this may need to be discharged in a prescribed manner.

NON-RINNAI FIELD SUPPLIED ACCESSORIES

Your home comfort system may include field-supplied accessories that do not form part of this regular maintenance cycle. These may include: ductwork, fittings, filters, grilles, zone motors, auxiliary heaters, third party controls and other non-Rinnai supplied items.

These items may also require attention in accordance with the Original Equipment Manufacturer's (OEM) recommendations. Your installer can provide details in this regard, and should be consulted for any warranty or service matters for these items. Whilst they are an integral part of your home comfort system, these non-Rinnai items are not covered by your Rinnai Product Warranty.

Third party controls and zoning systems that interfere with the correct operation of your Rinnai Heat Pump system, and any consequential damages to Rinnai equipment as a result of such incorrect operation, will not be covered by Rinnai Warranty.

OPERATION

UNIT SPECIFICATIONS & FEATURES

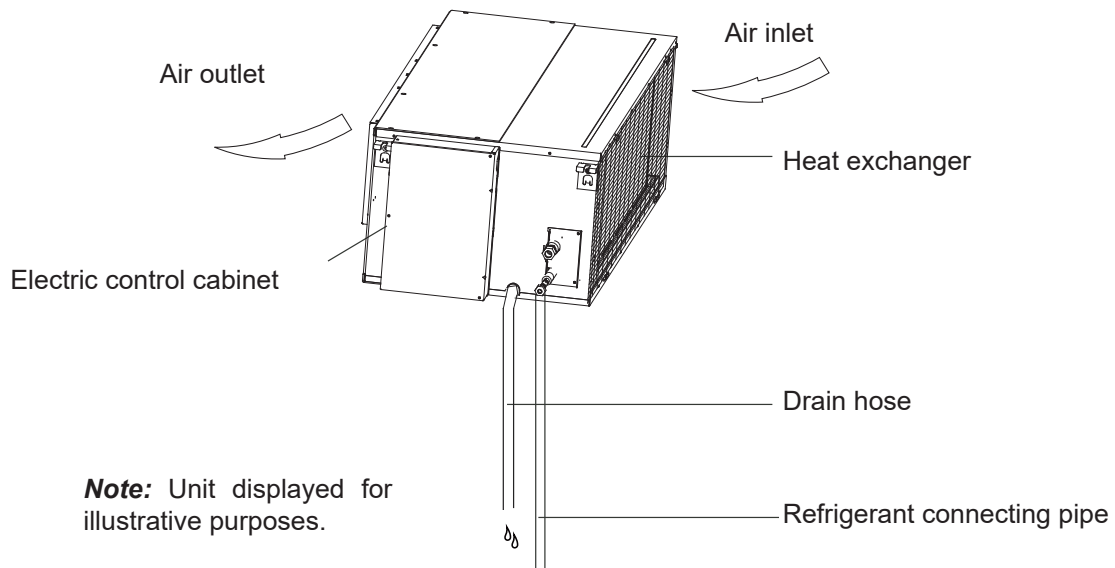

OPERATING TEMPERATURE

When your air conditioner is used outside of the following temperature ranges, certain safety protection features may activate and cause the unit to disable.

INVERTER SPLIT TYPE

Temperature	COOL mode	HEAT mode	DRY mode
Room Temperature	16°C – 32°C	0°C – 30°C	10°C – 32°C
Outdoor Temperature	-15°C – 50°	-20°C – 24°C	0°C – 50°C



To further optimise the performance of your appliance, do the following:

- **Keep doors and windows closed.**
- Limit energy usage by using TIMER ON and TIMER OFF functions.
- **Do not block air inlets or outlets.**
- **Regularly inspect and clean return air filters.**

CARE & MAINTENANCE

CLEANING THE AIR FILTER

The air filter requires inspection and cleaning at least every two weeks. Consult your installer for location of filters on ducted systems.



A dirty air filter will reduce the efficiency, effectiveness and air quality of your system. Failure to clean the filters regularly can also cause condensation to form and drip from the indoor unit when operated in cooling mode during humid conditions.

CLEANING THE OUTDOOR UNIT

The outdoor (condensing) unit draws air into the unit and dissipates it away from the appliance. Periodic inspection is required to ensure vegetation has not grown around the unit (plants, weeds etc.).

The cabinet should be kept clean and have the recommended clearances maintained. Ensure the discharge air is free to dissipate and under no circumstances recirculates back into the unit.

Ensure there is no water build up (including from condensate drain) on or around the unit.



Any unit repairs, maintenance and cleaning of the outdoor unit should be performed by an authorised dealer or licensed service provider.

GENERAL MAINTENANCE

Maintenance - For Prolonged Periods of Non Use

If you plan not to use your air conditioner for an extended period of time, do the following.

- Clean all filters
- Turn ON Fan function until unit dries out completely
- Turn off the unit and disconnect the power
- Remove batteries from remote control.

MAINTENANCE - PRE-SEASON INSPECTION

After long periods of non-use, or before periods of frequent use, do the following:

- Check for damaged wires
- Clean all filters
- Check for leaks
- Replace batteries
- Make sure nothing is blocking all air inlets and outlets of both the indoor or outdoor units.

INSTALLATION RECORD - INSTALLER DETAILS

Company Name: _____

Company Address: _____

Telephone: _____

Mobile Phone: _____

Email: _____

Certificate of Compliance / Certification No. _____

Authorised Persons - Licence No. _____

Installers Name: _____

Installers Signature: _____

Installation Date: _____

INSTALLATION RECORD - SYSTEM DETAILS

Model Number : _____

Serial Number Indoor Unit: _____

Serial Number Outdoor Unit: _____

Installation Address: _____

CUSTOMER CARE PROGRAM

Please ensure you register your product warranty on line at rinnai.com.au.

The Rinnai Customer Care Program is designed to help you get the most out of your new system.

Service and maintenance in accordance with the Service Maintenance Schedule on page 15 is essential in ensuring the prolonged useful life of your system, and help ensure it operates at optimum efficiency. We may contact you before each winter or summer season with preferential offers for preventative maintenance services which will keep your Rinnai system in great condition.



Service maintenance is not covered under warranty and is a chargeable service. All units must have safe and reasonable access and be installed in compliance with the installation instructions supplied with the unit. Some installations may require two service personnel to attend, in accordance with Health and Safety requirements.

Also note that all refrigerated air conditioning systems have air filters that require regular inspection and cleaning. Please refer to "Cleaning the Air Filter" on page 13.

SERVICE MAINTENANCE SCHEDULE - DUCTED AIR CONDITIONING SYSTEMS

Your Rinnai Ducted Air Conditioning System should be maintained annually after the date of installation by a qualified licensed technician in accordance with the Schedule below. Failure to do so during the product warranty period may void your warranty. This periodic service and maintenance will prolong the useful life of the unit, and help keep it running safely and at optimum efficiency.

Date of Installation	/ /		Installed By:				
YEAR OF SERVICE	1	2	3	4	5	6	7
Service Date	/ /	/ /	/ /	/ /	/ /	/ /	/ /
Service Company / Technician							
Ambient Temperature at CDU (°C)							
ELECTRICAL							
Wiring, Electrical connections							
Fan Motors							
Capacitors (if applicable)							
Printed circuit boards							
MAJOR COMPONENTS							
Outdoor unit clearances							
Outdoor unit condensate tray							
Outdoor unit condensate drain							
Outdoor unit fixing							
Indoor unit clearances							
Indoor unit condensate tray							
Indoor unit condensate drain							
Refrigerant charge							
Refrigeration connections							
Fan assemblies							
CONTROLS							
Thermostat(s)							
Zone Controls (if applicable)							
SYSTEM OPERATION							
Sequence of operation							
Return Air Temp -Cooling/ Heating	°C	°C	°C	°C	°C	°C	°C
Outlet Air Temp-Cooling/Heating	°C	°C	°C	°C	°C	°C	°C
Outdoor unit - Liquid line pressure	kPa	kPa	kPa	kPa	kPa	kPa	kPa
Outdoor unit - Suction line pressure	kPa	kPa	kPa	kPa	kPa	kPa	kPa
Zone Operation (if applicable)							
GENERAL INSTALLATION - RELATED AND 3rd PARTY COMPONENTS (NOT RINNAI PRODUCTS)*							
Ductwork and fittings							
Return air grille & filters							
Airflow through system							
Refrigerant pipework							
Safety tray							
Zone motors							
CONSUMABLES**							
Capacitors							
Filters							
Batteries (if applicable)							

* Installation and other field supplied components are not covered by Rinnai Product Warranty. These include, but are not limited to, control wiring, ducting, return air filter(s) grille, register, diffuser, zone motors, controls/thermostats, pipework, fabricated or added components and refrigerant gas and electrical connections to the appliance. These should be inspected as they can affect the performance, reliability and safety of the system.
 **Units contain consumable items that may require periodic replacement and are not covered by Rinnai product warranty (e.g. filters, capacitors and batteries).

ACTION CODES					
Inspected - Working Correctly - No Action Required	Adjusted Part	Cleaned Part	Replaced Part	Repaired Part	Referred to Installer
✓	A	C	R	RP	RI

SAVE A SERVICE CALL



If problems persist contact a local dealer or your nearest customer service centre.

Provide them with a detailed description of the unit malfunction as well as your model number.

SYMPTOM	CAUSE
Unit does not turn on when pressing ON/OFF button.	The unit has a 3 minute protection feature that prevents the unit from overloading. The unit cannot be restarted within three minutes of being turned off.
The unit changes from COOL/ HEAT mode to FAN mode.	The unit may change its setting to prevent frost from forming on the unit. Once the temperature increases, the unit will start operating in the previously selected mode again.
	The set temperature has been reached, at which point the unit turns off the compressor. The unit will resume operation when the temperature fluctuates again.
The outdoor unit emits white mist.	When the unit restarts in HEAT mode after defrosting, white mist may be emitted due to moisture generated from the defrosting process.
The indoor unit makes noises.	Water flowing noise, This is the sound of refrigerant flowing inside the indoor unit and is normal.
Both the indoor unit and outdoor unit make noises.	Low hissing sound during operation: This is normal and is caused by refrigerant gas flowing through both indoor and outdoor units.
	Low hissing sound when the system starts, has just stopped running, or is defrosting: This noise is normal and is caused by the refrigerant gas stopping or changing direction.
The outdoor unit makes noises.	The unit will make different sounds based on its current operating mode.
The unit emits a bad odour	The unit may absorb odours from the environment (such as furniture, cooking, cigarettes, etc.), which may be emitted during operation.
	The unit's filters have become mouldy and should be cleaned.
The fan of the outdoor unit does not operate.	During operation, the fan speed is controlled to optimise performance.
The air conditioner stops running.	Check power supply.
	If a power failure has occurred. Turn off the air conditioner when a power failure occurs. When the power is restored, wait 3 minutes, and then turn on the air conditioner.
	Check the air conditioner has not been turned off automatically by a programmed off timer. Press the power button on the remote control.
	Circuit Breaker tripped or fuse blown. Reset or replace, if problem persists contact Rinnai.
	Timer is activated. Turn timer off
The fan of the outdoor unit does not operate.	During operation, the fan speed is controlled to optimise performance.
The air conditioner stops running.	Check power supply.
	If a power failure has occurred. Turn off the air conditioner when a power failure occurs. When the power is restored, wait 3 minutes, and then turn on the air conditioner.
	Check the air conditioner has not been turned off automatically by a programmed off timer. Press the power button on the remote control.
	Circuit Breaker tripped or fuse blown. Reset or replace, if problem persists contact Rinnai.
	Timer is activated. Turn timer off

SYMPTOM	CAUSE
The air conditioner does not generate cool / hot air.	Air is not circulating properly. Make sure that there are no curtains, blinds or furniture blocking the front of the air conditioner.
	The air filter is dirty. Clean the air filter once every 2 weeks. See "Cleaning Air Filter" for more information.
	The room temperature is too high. In summer, it may take some time to cool indoor air. In this case, select the turbo cool operation to cool indoor air quickly.
	The desired temperature is higher than the set temperature. Set the desired temperature to a level lower than the current temperature.
	There is a heating source nearby. Avoid using a heat generator such as an electric oven or a gas burner while the air conditioner is in operation
	The FAN ONLY mode of operation is selected. In this mode, air blows from the air conditioner without cooling or heating the indoor air. Switch the operation mode to the cooling, heating or auto.
	The air inlet or outlet of either unit is blocked. Turn the unit off, remove the obstruction and turn it back on.
	Doors and windows are open. Make sure that all doors and windows are closed while operating the unit.
	Excessive heat is generated by sunlight. Close windows and curtains during periods of high heat or bright sunshine.
	Too many sources of heat in the room (people, computers, and electronics etc). Where possible reduce the amount of heat sources.
	Low refrigerant due to a leak or after long-term use, contact Rinnai.
Poor heating performance.	The outdoor temperature is lower than 7°C. Use an auxiliary heating device.
	Doors and windows are open. Make sure that all doors and windows are closed while operating the unit.
It is not possible to adjust the fan speed.	In some operation modes, you cannot adjust the fan speed. Select an operation mode in which you can adjust the fan speed.
It is not possible to adjust the temperature.	In some operation modes, such as the auto or fan only modes, you can not adjust the temperature. Select an operation mode in which you can adjust the temperature.

TROUBLESHOOTING

TROUBLESHOOTING TIPS

When problems occur, please check the following possible causes before contacting your nearest Customer Service Centre.

PROBLEM	POSSIBLE CAUSES	SOLUTION
Poor cooling performance.	Temperature setting may be higher than the ambient room temperature	Lower the temperature setting
	The heat exchanger on the indoor or outdoor unit is dirty	Clean the affected heat exchanger
	The air filter is dirty	Remove the filter and clean it according to instructions
	The air inlet or outlet of either unit is blocked	Turn the unit off, remove the obstruction and turn it back on
	Doors and windows are open	Make sure that all doors and windows are closed while operating the unit
	Excessive heat is generated by sunlight	Close windows and curtains during periods of high heat or bright sunshine
	Too many sources of heat in the room (people, computers, electronics etc)	Reduce amount of heat sources
The unit is not working	Power failure	Wait for the power to be restored
	The power is turned off	Turn on the power
	The fuse is burned out	Replace the fuse
	Remote control batteries are dead	Replace batteries
	The Unit's 3-minute protection has been activated	Wait three minutes after restarting the unit
	Timer is activated	Turn timer off
The unit starts and stops frequently	There's too much or too little refrigerant in the system	Check for leaks and recharge the system with refrigerant
	There is air, incompressible gas or foreign material in the refrigeration system.	Evacuate and recharge the system with refrigerant
	System circuit is blocked	Determine which circuit is blocked and replace the malfunctioning piece of equipment
	The compressor is broken	Replace the compressor
	The voltage is too high or too low	Install a manostat to regulate the voltage
Poor heating performance	The outdoor temperature is extremely low	Check for leaks and recharge the system with refrigerant
	Cold air is entering through doors and windows	Make sure that all doors and windows are closed during use
	Low refrigerant due to leak or long-term use	Check for leaks, re-seal if necessary and top off refrigerant



If problems persist after performing the checks and diagnostics above, turn off your unit immediately and contact a local dealer or your nearest customer service centre.

WHEN TO CALL FOR SERVICE

If ANY of the following conditions occurs, turn off your unit immediately!

- The power cord is damaged or abnormally warm
- There is a burning smell coming from the unit
- The unit emits loud or abnormal sounds
- When operated if a circuit breaker (safety, ground) is thrown or a fuse is blown
- Water leaks from the safety drain
- Parts are ejected out of the unit
- Foreign objects fall into the unit
- If the unit has been exposed to flooding.

DO NOT ATTEMPT TO FIX THESE YOURSELF! TURN OFF THE AIR CONDITIONER & CONTACT RINNAI.

WARRANTY

TERMS OF WARRANTY – AUSTRALIA

Rinnai Australia Pty. Ltd. ABN 74 005 138 769, 82-88 Mills Road, Braeside, Victoria, 3195.

1 DEFINITIONS

The terms listed below shall have the following meanings:

- 1 **“Authorised Service Representative”** means an independent service contractor authorised by Rinnai or Rinnai service personnel.
- 2 **“Rinnai”** means Rinnai Australia Pty Ltd (ABN 74 005 138 769) and any related company.
- 3 **“Certificate(s) of Compliance”** means certificate(s) issued by licensed personnel (including plumbers, refrigeration mechanics, electricians or other relevant tradespeople) to certify that any prescribed works comply with applicable regulatory requirements.
- 4 **“Certificate(s) of Occupancy”** means certificate(s) issued by the local government authority (or similar organisation) which certifies that a home can be occupied.
- 5 **“Installation Site”** means the site at which the Product is originally installed.
- 6 **“Normal Business Hours”** means 8:30am to 5:00pm Monday to Friday, excluding public holidays.
- 7 **“Operating/Installation Instructions”** means the user manual or other documentation which provides detailed instructions on the proper operation and maintenance of the Product.
- 8 **“Other Applications”** means any Product used for purposes other than Residential & Light Commercial Applications. Other Applications may include but are not limited to factory, IT/Server room, telephone exchange, processing area (e.g. bakery, kitchen, warehouse, swimming pool, agricultural facilities such as a nursery). Any Product which has been installed, for whatever purpose, as a retrofit component to an existing system, will also be classed as being part of an “Other Application” regardless of the purpose of use of the existing system into which such product has been installed.
- 9 **“Purchaser”** means the end user of the Product, the person named as owner in the Warranty certificate, the holder of the Proof of Purchase or the holder of a property transfer document where the Product is included as part of the chattels.
- 10 **“Product”** means the equipment purchased by the Purchaser and described in Section 2 of this document.
- 11 **“Proof of Purchase”** means a Tax Invoice or Receipt in respect of the Product. In the case of new constructions, a Certificate of Occupancy or a Certificate of Compliance that details the date of installation or commissioning will suffice.
- 12 **“Qualified Installer”** means the qualified installation contractor who is responsible for performing the installation work in the manner prescribed by local and statutory regulations, including compliance with any relevant and to Rinnai specifications, including Australian Standards.
- 13 **“Residential & Light Commercial Applications”** means any Product for use in residential or light commercial applications where
 - a) the Product is solely used for the purpose of human comfort; and
 - b) the ambient temperature of the space the Product is intended to heat or cool is influenced solely or primarily by natural exterior weather conditions rather than by man-made or mechanical heat sources.

Examples of Residential & Light Commercial Applications include, homes, offices, hotels, apartments, nursing homes, hospitals, health care premises, shopping centres, and retail stores.

2 TERMS OF WARRANTY

2.1 Subject to the terms of warranty set out in this document, and effective from the date of completion of installation, the product is warranted to be free from defects in materials & factory workmanship for the period set out in the table below:

	PRODUCT GROUPS	PARTS	LABOUR
Residential and Light Commercial	Evaporative Coolers & Ducted Gas Heaters (excluding Compact Classic Series)	5 Years *Extended 4 Years Option	5 Years *Extended 4 Years Option
	Ducted Gas Heaters - Compact Classic Series	3 Years	3 Years
	Refrigerated Air Conditioning Products	7 Years	7 Years
	Add-On ICE Refrigerated Cooling System	5 Years	5 Years
	VRF Air Conditioning Products	5 Years	5 Years
	Ducted Gas Heaters - Heat Exchangers and Burners Evaporative Coolers - Structural components only	10 Years	N/A
	Portable Air conditioning ⁽¹⁾ / Dehumidifier ⁽¹⁾ / Air Purifier ⁽¹⁾	2 Years	N/A
	Electric Panel Heaters ⁽¹⁾	7 Years	N/A
	Electric Fire Heater	5 Years	5 Years
	Outdoor Radiant Heater	3 Years	1 Year
	Wi-Fi Devices	1 Year	1 Year
Commercial	Refrigerated Air Conditioning Products	2 Years	1 Year
Other Applications	All Product Groups	2 Years	1 Year
After Market	Spare Parts	1 Year	N/A
*Extended Warranty Option	Up to 4 year extended warranty (in addition to the standard warranty period listed above) applies on selected products when you opt in to the Rinnai Service Advantage program. This program has terms and conditions, including the requirement for scheduled servicing of the product by Rinnai. To participate in the program you must register your product online at: www.rinnai.com.au/support-resources/warranty-registration/ within the first 12 months of the product being installed.		

⁽¹⁾ To make a claim under this warranty, please contact your place of purchase within the warranty period.

- 2.2 Rinnai will determine in its sole discretion, which classification the Product fits into and the corresponding Warranty that shall apply.
- 2.3 An Authorised Service Representative will repair or replace, at its option, the Product or any part of the Product that its examination shows to be defective. The repair or replacement shall be performed during Normal Business Hours by an Authorised Service Representative. Repair by persons other than an Authorised Service Representatives may void the Warranty.
- 2.4 Alternatively to clause 2.3 above, Rinnai can at its discretion elect to pay you an amount equivalent to the cost of repairing or replacing the Product.
- 2.5 If Rinnai provides you with either the replacement costs or replacement product, ownership of the original Product shall immediately transfer to Rinnai.
- 2.6 Rinnai is responsible for reasonable costs associated with legitimate warranty claims, including call-out of an Authorised Service Representative to inspect the Product. Rinnai is not responsible for:
- costs for tradespeople engaged by you that are not Rinnai Authorised Service Representatives.
 - any costs, including call out costs for a Rinnai Authorised Service Representatives, associated with a Product which is determined upon inspection not to be covered by this warranty.
- 2.7 Rinnai will reimburse any reasonable costs associated with making a legitimate warranty claim against Rinnai which are not otherwise specified above.
- 2.8 The Warranty of the Product requires that, in addition to all other conditions, the Purchaser conducts regular and/or preventative maintenance as may be specified by the Operating/Installation Instructions or otherwise directed by Rinnai and required by the level of usage and the usage environment, including the use of correct and uncontaminated refrigerants and lubricants. Refrigeration, plumbing and electrical works must be undertaken by licensed personnel.
- 2.9 Where a Product or failed component is replaced under warranty, the time remaining on the original Product warranty period will continue to apply and the replacement product or part will be subject to the original warranty period only.

3 CONDITIONS OF WARRANTY

- 3.1 The Purchaser may only obtain the benefit of the Warranty if the Purchaser:
- maintains and has the Product serviced in accordance with the instructions set out in the service section of the relevant Service or Owner's Manual;
 - complies with clause 7 "Purchaser's Responsibilities";
 - notifies Rinnai within 30 days of a defect occurring or, in the case of a latent defect, becoming apparent, that a claim is being made under this Warranty; and
 - provides, in support of the claim made under this Warranty, a proof of date of completion of installation.
- 3.2 This document (and any statutory consumer guarantees) represents the only Warranty given by Rinnai in respect of the Product. No other person or organisation is authorised to offer any alternative warranty on behalf of Rinnai.
- 3.3 If the date of completion of installation cannot be established to Rinnai's satisfaction, the date shall be deemed to be 2 months after the date of manufacture or date of sale by Rinnai, whichever is the latter.
- 3.4 This warranty applies to Products which are manufactured on or after the date of publication of this warranty but before the next date of publication of this warranty.

4 EXCLUSIONS

- 4.1 This Warranty **DOES NOT** cover:
- damage, problems or failure resulting from improper operation and/or inadequate maintenance by the Purchaser (refer Purchaser's Responsibilities section below);
 - damage, problems or failure resulting from improper or faulty installation. The Product must be installed by a Qualified Installer in accordance with applicable regulations. Where applicable, Certificate(s) of Compliance must be obtained by the purchaser from the Qualified Installer and presented to the Authorised Service Representative;
 - damage, problems or failure caused by factors external to the Product including, but not limited to, faulty or poor external electrical wiring, incorrect or faulty power supply, voltage fluctuations, over voltage transients or electromagnetic interference, inadequate or faulty gas, drainage services, or water services, including water pressure, and non-potable water;
 - damage, problems or failure caused by acts of God, fire, wind, lightning, flood, storm, hail storm fallout, vandalism, earthquake, war, civil insurrection, misuse, abuse, negligence, accident, pests, animals, pets, vermin, insects, spiders/bugs or entry of foreign objects or matter into the Product such as dirt, debris, soot or moisture;
 - damage, problems or failure caused by environmental conditions including, but not limited to, excessive moisture, salt or other corrosive substances or atmospheric conditions;
 - Product which has been installed in a portable or mobile building, structure or application including, but not limited to, a caravan, boat or trailer;
 - Product which has been re-installed at a location other than the original site;
 - any consumable item supplied with the Product including, but not limited to, an air filter, battery, fan belt, igniter or cooler pad;
 - installation of third-party components that may be attached to the Product. These include, but are not limited to, control wiring, ducting, return air filter(s) grille, register, diffuser, zone motors, controls/thermostats, pipe work and fabricated or added components. These items remain solely the responsibility of the Qualified Installer;
 - installations where electrics/electronics may be subjected to moisture/chemicals (e.g. swimming pools or nurseries);
 - any repair, which is needed as a result of an accident, misuse, abuse or negligence;
 - Product that is utilised in an environment (indoor and outdoor) outside its specified operating range; and
 - fair wear and tear to the Product.
 - On-site labour warranty on portable (non-fixed installation) Products – In respect of such Products the Purchaser must return the Product to the supplier for repair or replacement).

5 LIMITATIONS

- 5.1 Third parties are often involved in providing advice to consumers about the climate control solutions best suited to the consumer's needs. Any advice or recommendations given by such parties, including advice about Product fitness for purpose and overall system design, sizing and application are not the responsibility of Rinnai. This includes but is not limited to the heat load calculations, airflow and system balancing.
- 5.2 This Warranty does not apply to any Product installed at an Installation Site which is outside Australia.
- 5.3 Except where inconsistent with the purchaser's statutory rights and the rights given by this Warranty, all liabilities of Rinnai for any direct, special, indirect or consequential loss or damage, any damage or expense for personal injury or any loss or destruction of property, arising directly or indirectly from the use or inability to use the Product or any of its parts and/or servicing the Product, are expressly excluded.

6 TRAVEL, TRANSPORT & ACCESS COSTS

- 6.1 The Purchaser must pay freight charges, in-transit insurance expenses and travelling costs for repairs/replacements under this Warranty, that are required to be performed 50km from the nearest Rinnai branch or Authorised Service Representative.
- 6.2 Subject to clause 6.3, Rinnai will pay freight charges, in-transit insurance expenses and travelling costs for repairs/replacements that are required to be performed less than 50km from the nearest Rinnai branch or Authorised Service Representative, subject to the following:
- Rinnai will arrange for such repairs/replacements and make any payment directly to the third party to provide the freight, in-transit insurance or travel services; or
 - if Rinnai considers appropriate, it will authorise the Purchaser in writing to pay for the relevant freight charges, in-transit insurance expenses or travelling costs and then, upon provision by the Purchaser to Rinnai of a tax invoice showing those costs have been incurred, reimburse the Purchaser for such costs which are within the terms of the authorisation. If the Purchaser pays for the relevant freight charges, in-transit insurance expenses or travelling costs without written authorisation from Rinnai, Rinnai will not reimburse the Purchaser for such costs.
- 6.3 The Purchaser must pay all costs and expenses in respect of:
- any service call out fee if the Product is not accessible for service
 - making the Product accessible for service, for example, restricted access or working at heights, or the labour cost for an additional person due to OHS requirements.
 - providing a safe working environment for installation, service, maintenance or repair of the Product;
 - any surcharge applicable in respect of supplying replacement parts outside Normal Business Hours; and
 - any other costs and expenses in relation to claiming the Warranty that is not covered by clause 6.2.

7 PURCHASER'S RESPONSIBILITIES

- 7.1 The Purchaser must operate and maintain the Product in accordance with the Operating Instructions and service maintenance schedule, including conducting an appropriate number of services to the unit during the Warranty period, based on usage and the usage environment including but not limited to;
- regularly cleaning the air filter(s) and replacing them where necessary;
 - replacing expired batteries or other consumables as required;
 - ensuring that the condensate drain is kept clean and clear of obstructions.

HOW TO MAKE A WARRANTY CLAIM:

If you wish to make a warranty claim in respect of any Portable Product, please return it to the place of purchase, or if that is not possible, contact Rinnai to enquire about alternative arrangements.

If you wish to make a warranty claim in respect of any fixed Product, please contact Rinnai on the details set out below to make arrangements for an Authorised Service Representative to inspect the product.

As per clause 2.6 of the Terms and Conditions of Warranty, purchasers are responsible for the costs of any repair and/or call out fee where, on inspection, the alleged defect is found by Rinnai's Authorised Service Representative not to be covered by this warranty or any statutory consumer guarantee applicable to the Product.

The Terms and Conditions of Warranty contain important information about your rights and obligations under this warranty. Please read them fully and carefully before making a claim.

NOTICE TO CONSUMERS UNDER AUSTRALIAN CONSUMER LAW

Our goods come with guarantees that cannot be excluded under the Australian Consumer Law. You are entitled to a replacement or refund for a major failure and compensation for any other reasonably foreseeable loss or damage. You are also entitled to have the goods repaired or replaced if the goods fail to be of acceptable quality and the failure does not amount to a major failure.

Our services come with guarantees that cannot be excluded under the Australian Consumer Law. For a major failure with the service, you are entitled to cancel your service contract with us and obtain a refund for the unused portion, or to compensation for its reduced value. You are also entitled to be compensated for any other reasonably foreseeable loss or damage. If the failure does not amount to a major failure you are entitled to have problems with the service rectified in a reasonable time and, if this is not done, to cancel your contract and obtain a refund for the unused portion of the contract.

The benefits provided by this Warranty are in addition to any other rights and remedies available to a consumer under the Australian Consumer Law and any other law which may apply to the goods and or services.

Rinnai Australia Pty Ltd

ABN 74 005 138 769 | AU45204

82-88 Mills Road, Braeside, Victoria, 3195
P.O. Box 460, Braeside, Victoria, 3195
Tel: (03) 9271 6625

Customer Support

Tel: 1300 555 545*

Monday to Friday, 8.00 am to 5.00 pm EST.

**Cost of a local call may be higher from a mobile phone.
(National calls from public phones in Australia are free.)*

For further information visit **www.rinnai.com.au**
or email **enquiry@rinnai.com.au**

Rinnai has a Service and Spare Parts network with personnel who are fully trained and equipped to give the best service on your Rinnai appliance. If your appliance requires service, please call Customer Support. Rinnai recommends that this appliance be serviced once a year.

With our policy of continuous improvement, we reserve the right to change, or discontinue at any time, specifications or designs without notice.