

DRAWING CHANGES				BY	CKD	DATE
REV	ECN NO	DESCRIPTION				

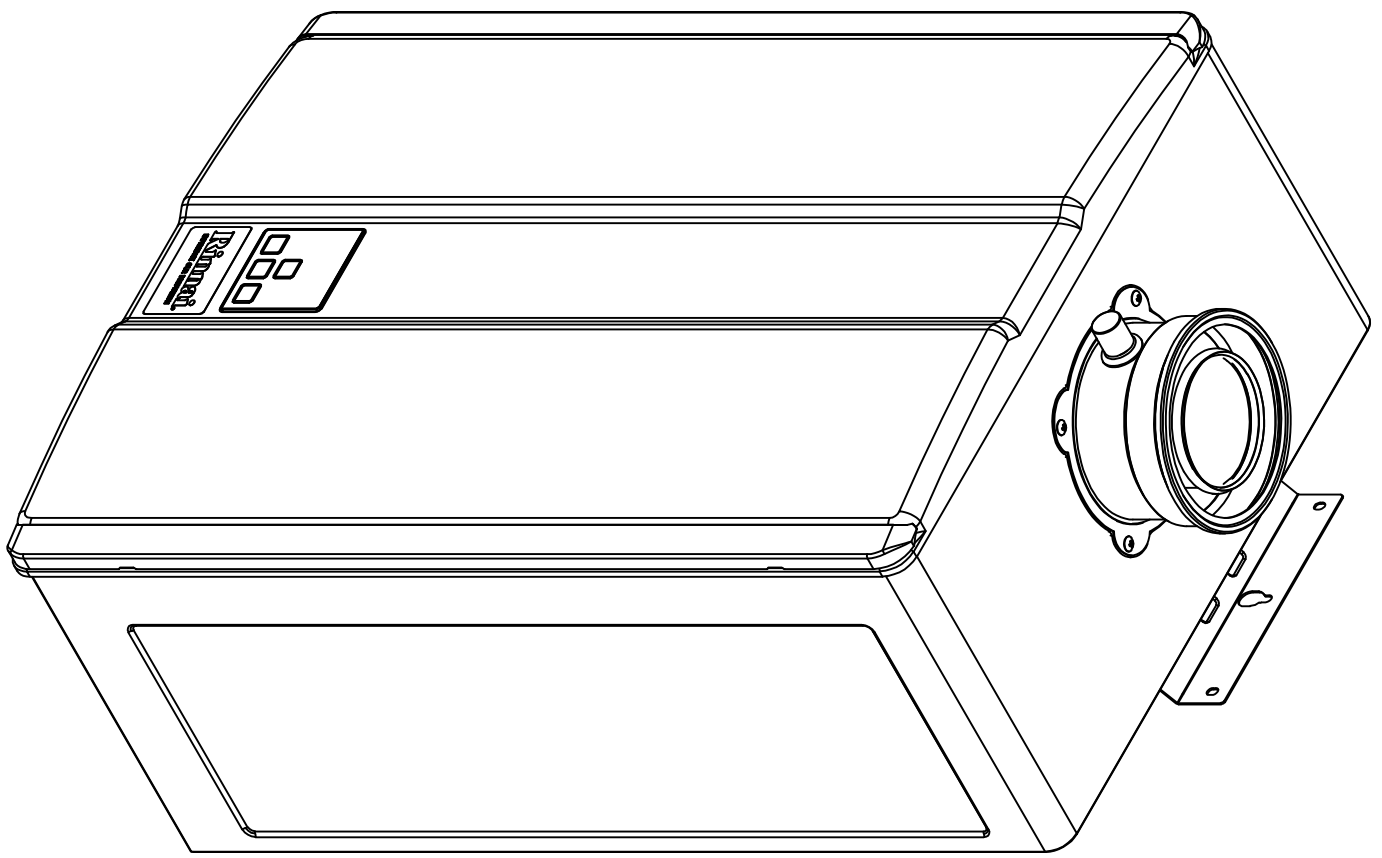

GENERAL NOTES	
THERMAL EFFICIENCY	97.6%
GAS CONSUMPTION	210 MJ/h
WEIGHT	29 kg
MIN WATER FLOW	2.4 L/min
OUTPUT CAPACITY	57.9 kW
POWER SUPPLY	240v 50Hz
GAS CONNECTION	R _{3/4} "(20mm)
COLD CONNECTION	R _{3/4} "(20mm)
HOT CONNECTION	R _{3/4} "(20mm)
CONDENSATE DRAIN	USE UPVC
FAN ASSISTED FLUE	YES
RINNAI FLUEING	FFPP
SOUND LEVEL	<49 DBA
MAX TEMP °C	85

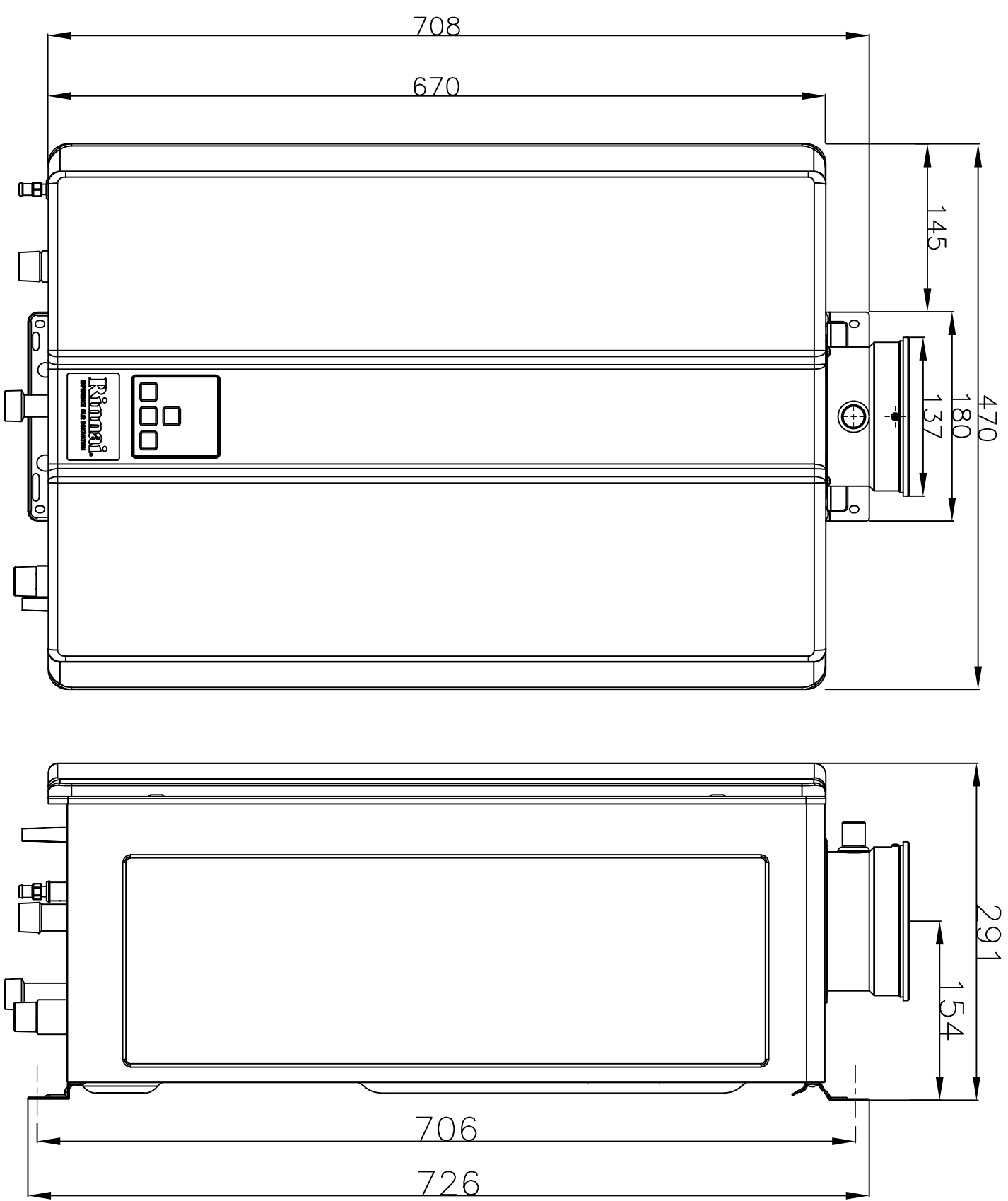
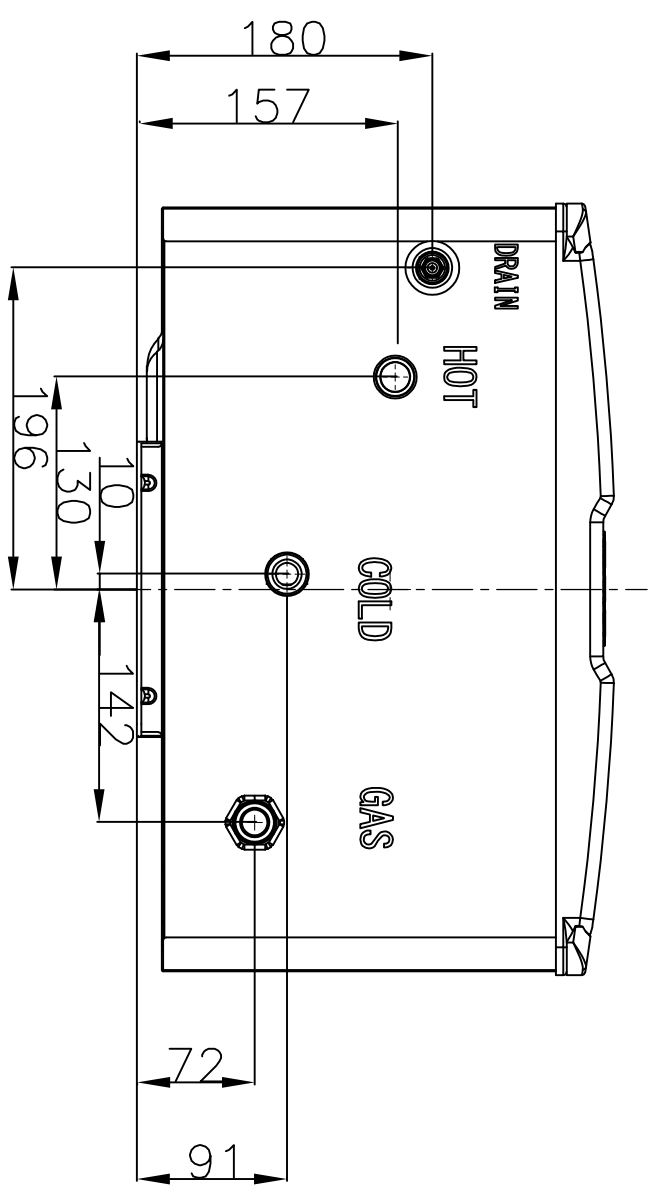

MATERIAL		DRAWN		RMP		Title	
TOLERANCE - UNLESS STATED		DATE		10/06/22		HD210 INTERNAL	
0. ±1.0		CHECKED		SVL		<h1>Rinnai</h1> <p>Australia Pty Ltd</p>	
0.0 ±0.5		APPROVED					
Angular ±1°						Weight	
FINISH:						SEE NOTES	
DIMENSIONS ARE IN MILLIMETERS AS 1:100						Drawing Number(PART NO)	
THIRD ANGLE PROJECTION						SK 0324	
DO NOT SCALE DRAWING						Revision	
						1	