

DRAWING CHANGES				BY	CKD	DATE
REV	ECN NO	DESCRIPTION				

GENERAL NOTES	
THERMAL EFFICIENCY	97.6%
GAS CONSUMPTION	210 MJ/h
WEIGHT	29 kg
MIN WATER FLOW	2.4 L/min
OUTPUT CAPACITY	57.9 kW
POWER SUPPLY	240V 50Hz
GAS CONNECTION	R <sub>3/4</sub> "(20mm)
COLD CONNECTION	R <sub>3/4</sub> "(20mm)
HOT CONNECTION	R <sub>3/4</sub> "(20mm)
CONDENSATE DRAIN	USE UPVC
SOUND LEVEL	<53 DBA
MAX TEMP °C	85

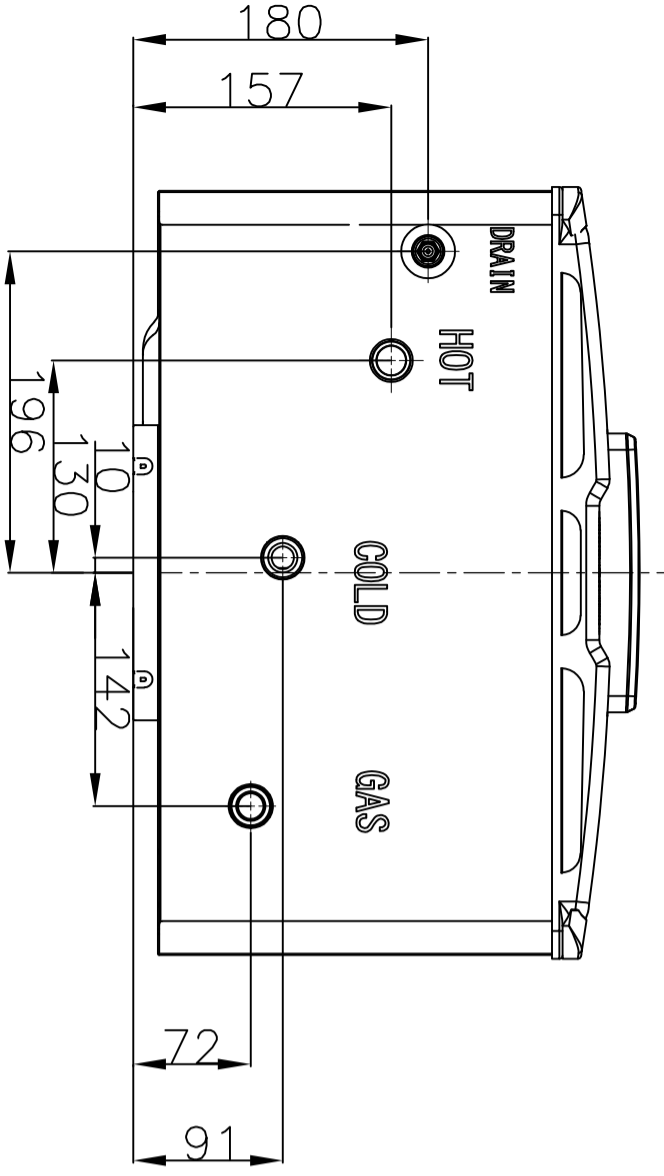
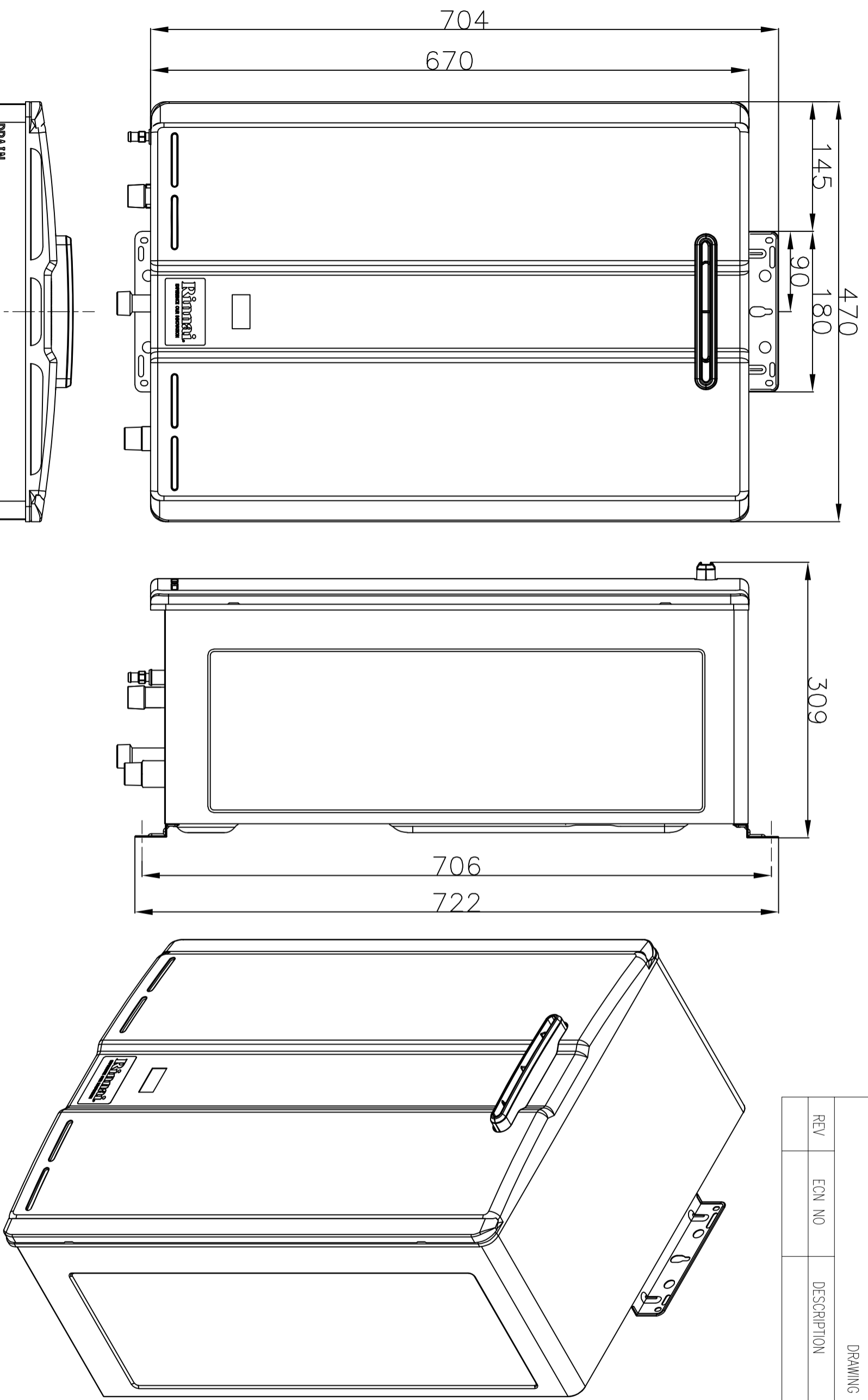

MATERIAL		DRAWN		RMP		Title	
TOLERANCE - UNLESS STATED		DATE		10/06/22		HD210 EXTERNAL	
0. ±1.0		CHECKED		SVL		Rinnai Australia Pty Ltd	
0.0 ±0.5		APPROVED				Weight	
Angular ±1°		DO NOT SCALE DRAWING				SEE NOTES	
DIMENSIONS ARE IN MILLIMETERS AS 1:100						Drawing Number(PART NO)	
THIRD ANGLE PROJECTION						SK 0323	
						Revision	
						1	