

DRAWING CHANGES					
REV	ECN NO	DESCRIPTION	BY	CKD	DATE

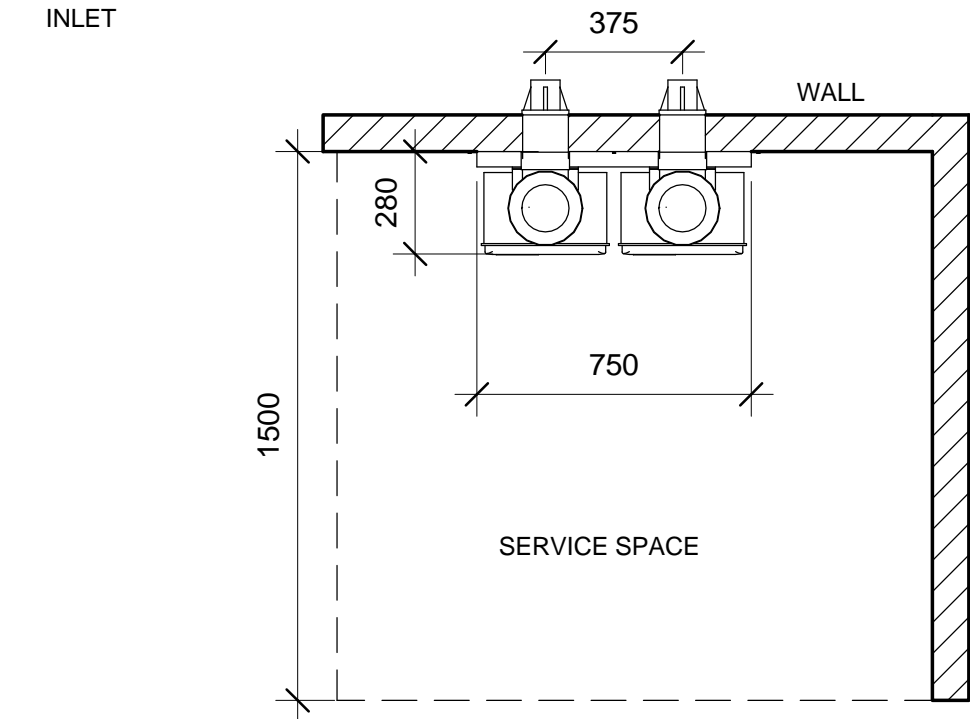

* COLD EXPANSION VALVE & NON RETURN VALVE NOT REQUIRED ON NON CIRCULATING SYSTEMS.

FLUED THROUGH ROOF OPTION TYPICAL

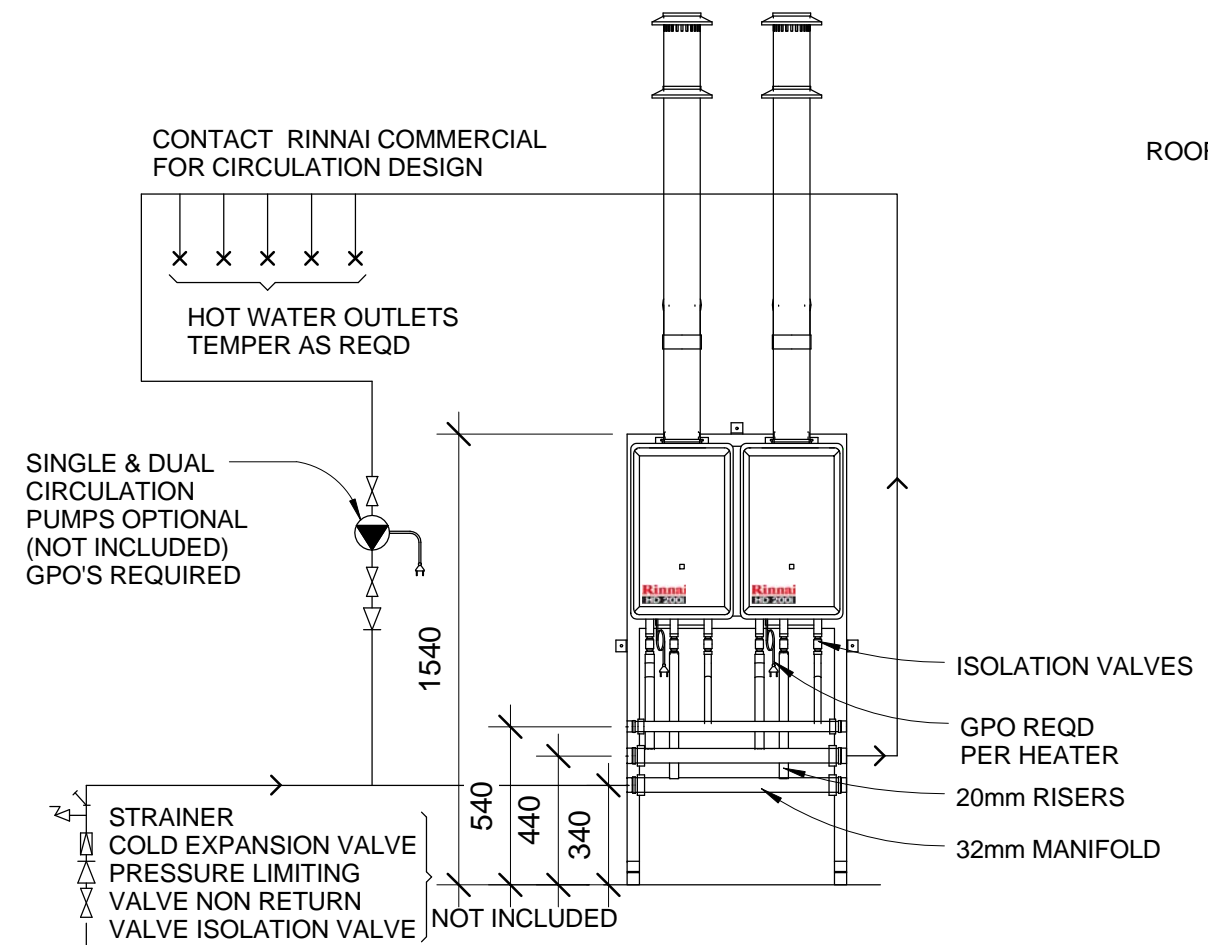
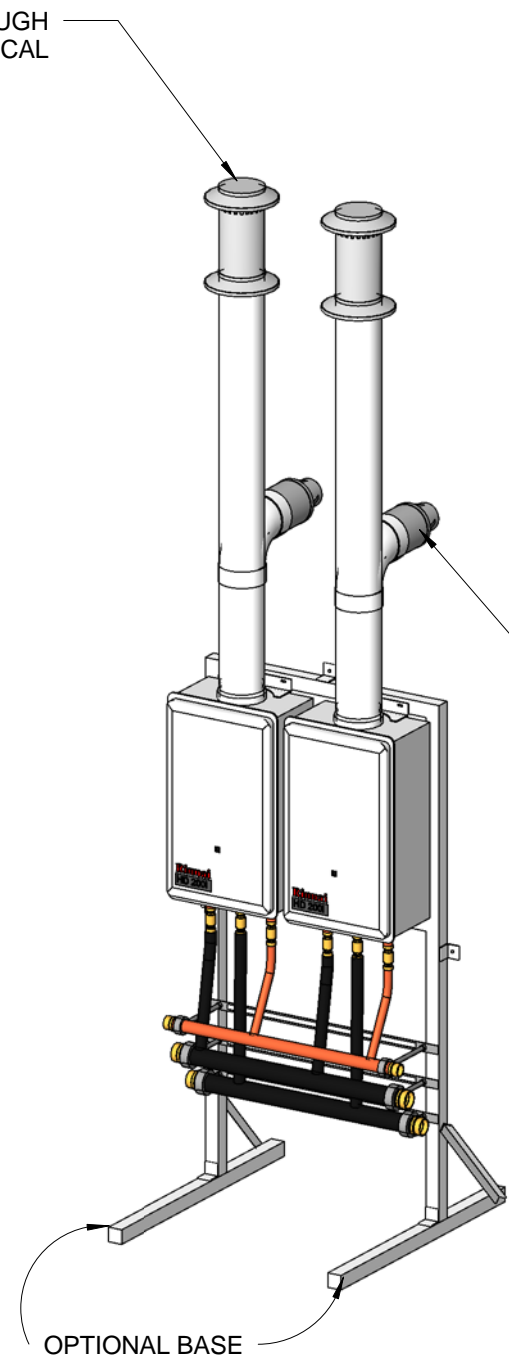

WEIGHT:

MP2 - 60 kg

HD200 HEATERS:

GAS LOAD EACH 200MJ
- NG 1.13 - 2.75 kPa
- LPG 2.75 kPa
FAN ASSISTED , BALANCED FLUE

ELECTRICAL:

240 V 10 AMP GPO
PER HD HEATER

MATERIAL	DRAWN	DAP	Rinnai Australia Pty Ltd		
TOLERANCE - UNLESS STATED	DATE	21/05/12			
0.±1.0 0.0 ±0.5	DIMENSIONS ARE IN MILLIMETERS AS 1:100	CHECKED	DEMAND DUO-MP2200I MANIFOLD PACK		
FINISH:	APPROVED		Weight	Drawing Number(PART NO)	Revision
	DO NOT SCALE DRAWING			RA-21-05-12-022	