

DRAWING CHANGES					
REV	ECN NO	DESCRIPTION	BY	CKD	DATE

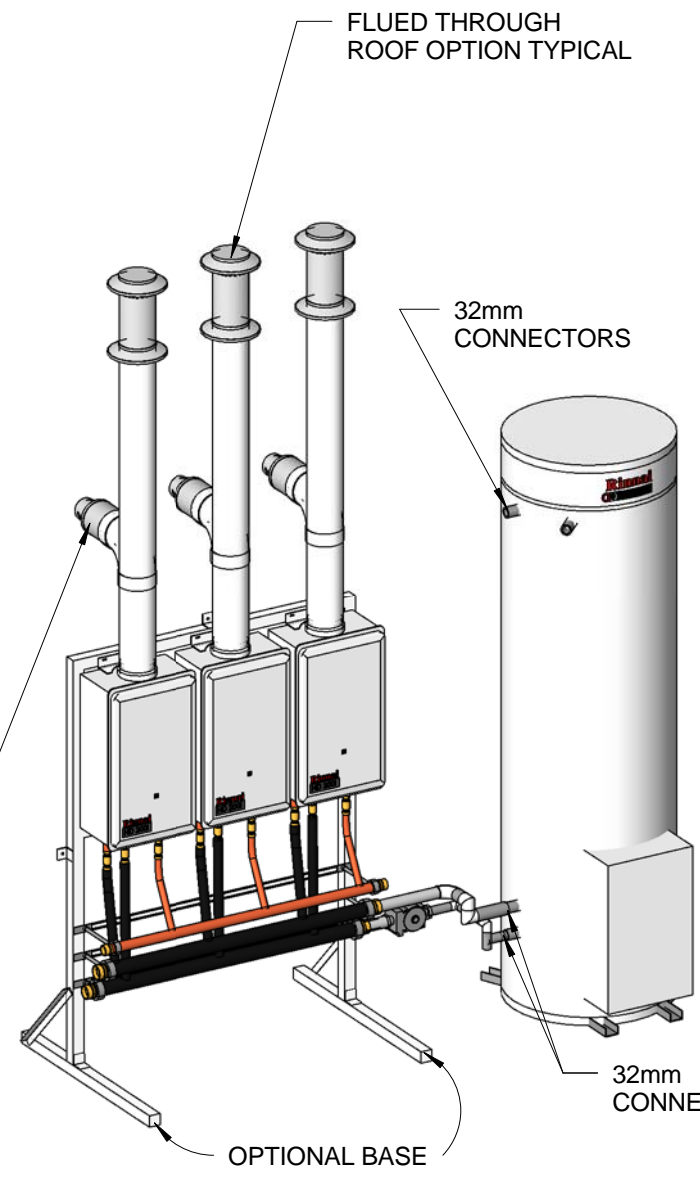
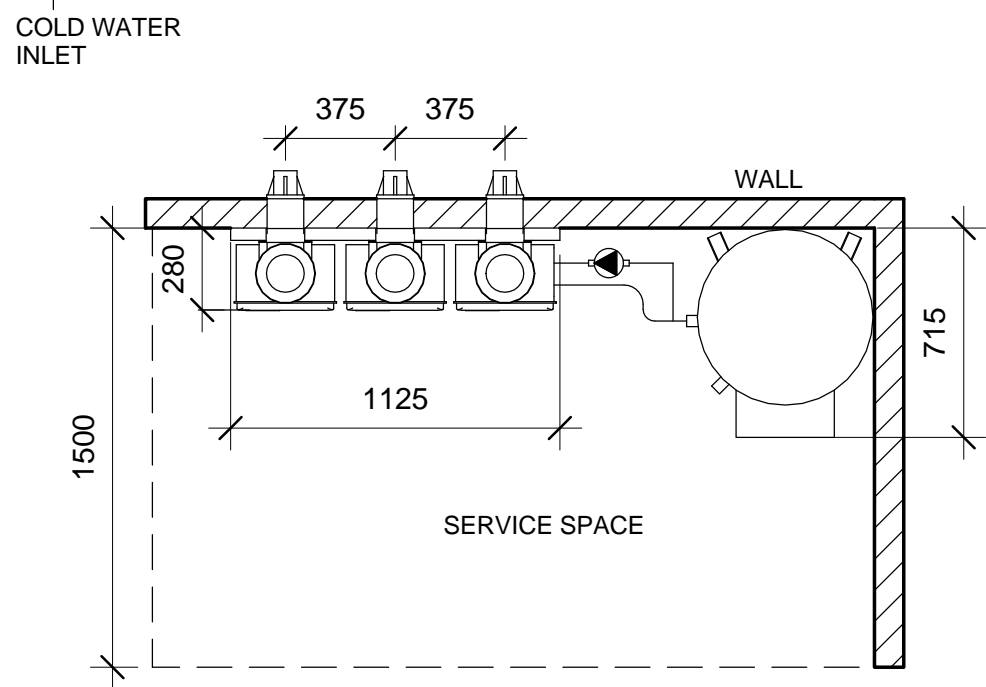
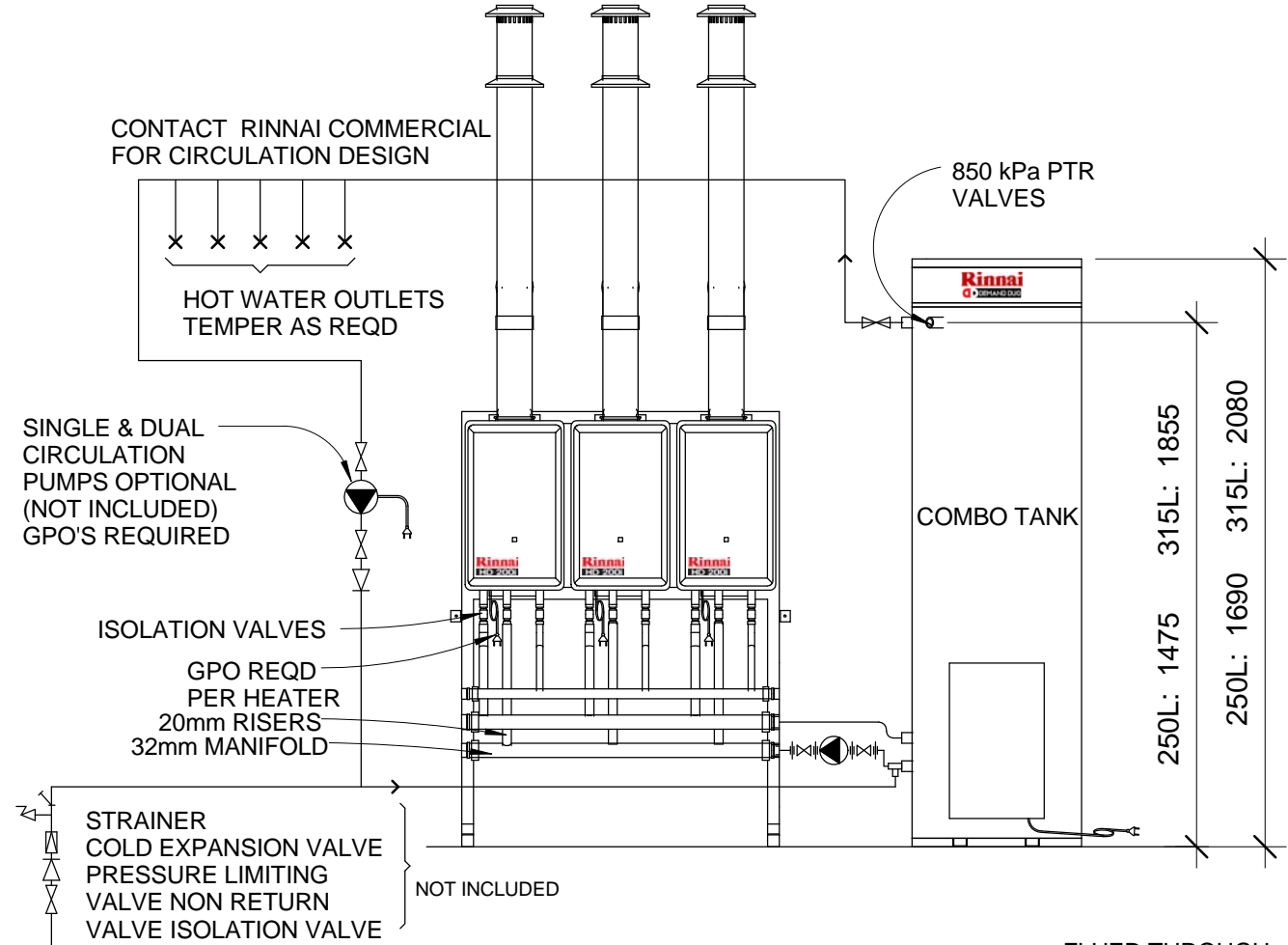

**TANK**

DRY WEIGHT: 250L - 60kg  
315L - 72kg

WET WEIGHT: 250L - 310kg  
315L - 385kg

SYSTEM WEIGHT: 135kg

**HD200 HEATERS:**  
GAS LOAD EACH 200MJ  
- NG 1.13 - 2.75 kPa  
- LPG 2.75 kPa  
FAN ASSISTED , BALANCED FLUE  
WEIGHT 20kg EACH APPROX

**THERMOSTAT:**  
FACTORY SET AT 65°

**PRIMARY PUMP:**  
DD3: GRUNDFOS UP25-80B  
WITH WEATHER PROOF COVER

**GENERAL NOTE:**  
TANK REQUIRES EXTERNAL GPO. PRIMARY PUMP CONNECTS INTO TANK GPO.

MATERIAL	DRAWN	DAP	<b>Rinnai Australia Pty Ltd</b>		
TOLERANCE - UNLESS STATED	DATE	21/05/12			
0.±1.0 0.0 ±0.5	DIMENSIONS ARE IN MILLIMETERS AS 1:100	CHECKED	<b>DEMAND DUO-DD3200I STORAGE HOT WATER</b>		
0.00 ±0.1 Angular ±1	THIRD ANGLE PROJECTION	APPROVED			
FINISH:	DO NOT SCALE DRAWING		Weight	Drawing Number(PART NO)	Revision
				RA-21-05-12-013	