

DRAWING CHANGES					
REV	ECN NO	DESCRIPTION	BY	CKD	DATE

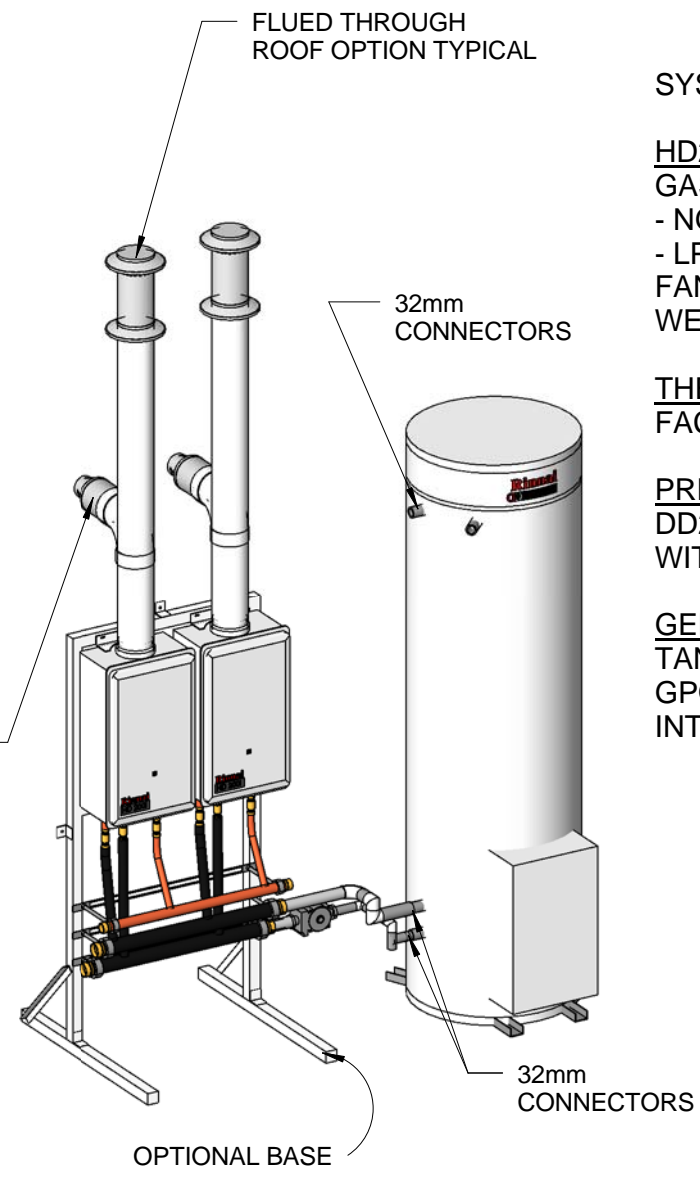
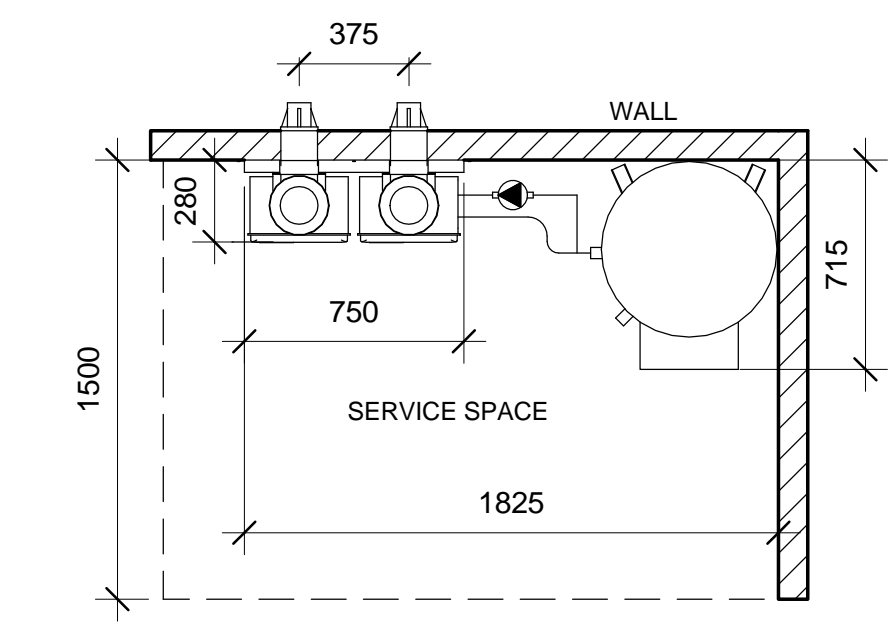
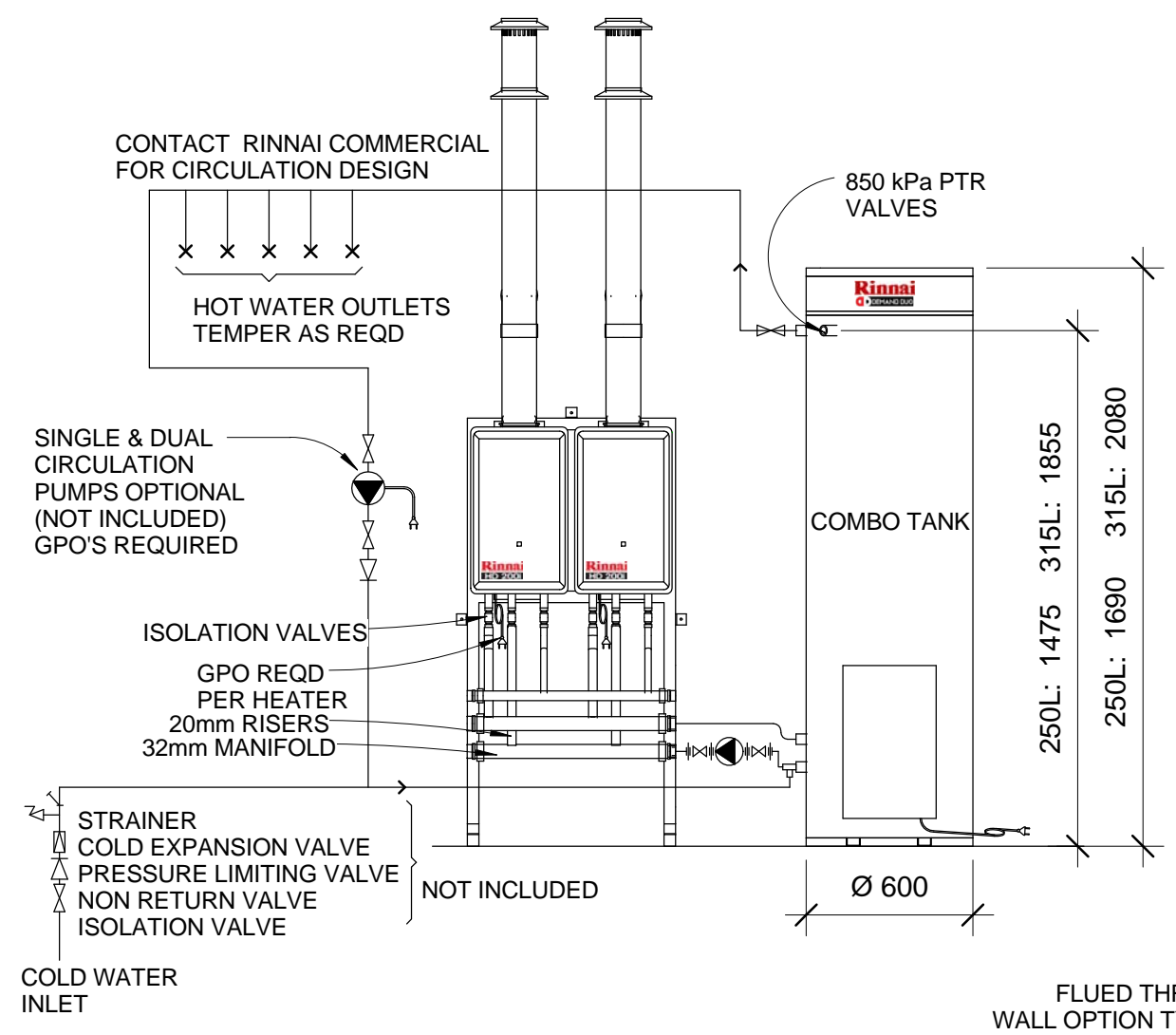

TANK

DRY WEIGHT: 250L - 60kg
315L - 72kg

WET WEIGHT: 250L - 310kg
315L - 385kg

SYSTEM WEIGHT: 115kg

HD200 HEATERS:
GAS LOAD EACH 200MJ
- NG 1.13 - 2.75 kPa
- LPG 2.75 kPa
FAN ASSISTED , BALANCED FLUE
WEIGHT 20kg EACH APPROX

THERMOSTAT:
FACTORY SET AT 65°

PRIMARY PUMP:
DD2: GRUNDFOS UP25-80B
WITH WEATHER PROOF COVER

GENERAL NOTE:
TANK REQUIRES EXTERNAL
GPO. PRIMARY PUMP CONNECTS
INTO TANK GPO.

MATERIAL	DRAWN	DAP	Rinnai Australia Pty Ltd		
TOLERANCE - UNLESS STATED	DATE	21/05/12			
0.±1.0 0.0 ±0.5	DIMENSIONS ARE IN MILLIMETERS AS 1:100	CHECKED	DEMAND DUO-DD2200I STORAGE HOT WATER		
0.00 ±0.1 Angular ±1	THIRD ANGLE PROJECTION	APPROVED			
FINISH:	DO NOT SCALE DRAWING		Weight	Drawing Number(PART NO)	Revision
				RA-21-05-12-012	