

CONTACT RINNAI COMMERCIAL FOR CIRCULATION DESIGN

HOT WATER OUTLETS  
TEMPER AS REQD

SINGLE & DUAL  
CIRCULATION  
PUMPS OPTIONAL  
(NOT INCLUDED)  
GPO'S REQUIRED

ISOLATION VALVES  
GPO REQD  
PER HEATER  
20mm RISERS  
32mm MANIFOLD

STRAINER  
COLD EXPANSION VALVE  
PRESSURE LIMITING VALVE  
NON RETURN VALVE  
ISOLATION VALVE

COLD WATER  
INLET

NOT INCLUDED

850 kPa PTR  
VALVES

COMBO TANK

Ø 600

250L: 1475  
315L: 1855  
250L: 1690  
315L: 2080

DRAWING CHANGES

REV	ECN NO	DESCRIPTION	BY	CKD	DATE

**TANK**

DRY WEIGHT: 250L - 60kg  
315L - 72kg

WET WEIGHT: 250L - 310kg  
315L - 385kg

SYSTEM WEIGHT: 115kg

**HD200 HEATERS:**

GAS LOAD EACH 200MJ  
- NG 1.13 - 2.75 kPa  
- LPG 2.75 kPa  
FAN ASSISTED , BALANCED FLUE  
WEIGHT 20kg EACH APPROX

**THERMOSTAT:**

FACTORY SET AT 65°

**PRIMARY PUMP:**

DD2: GRUNDFOS UP25-80B  
WITH WEATHER PROOF COVER

**GENERAL NOTE:**

TANK REQUIRES EXTERNAL  
GPO. PRIMARY PUMP CONNECTS  
INTO TANK GPO.

32mm  
CONNECTORS

OPTIONAL BASE

32mm  
CONNECTORS

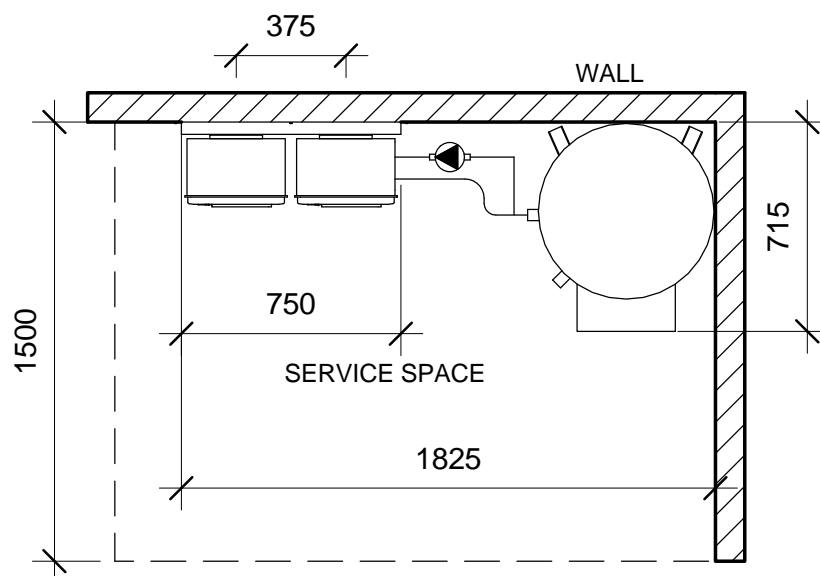

MATERIAL	DRAWN	DAP	<b>Rinnai Australia Pty Ltd</b>		
TOLERANCE - UNLESS STATED	DATE	21/05/12			
0.±1.0 0.0 ±0.5	DIMENSIONS ARE IN MILLIMETERS AS 1:100	CHECKED	Title <b>DEMAND DUO-DD220OE STORAGE HOT WATER</b>		
0.00 ±0.1 Angular ±1	THIRD ANGLE PROJECTION	APPROVED			
FINISH:	DO NOT SCALE DRAWING		Weight	Drawing Number(PART NO)	Revision
				<b>RA-21-05-12-006</b>	