

DRAWING CHANGES					
REV	ECN NO	DESCRIPTION	BY	CKD	DATE

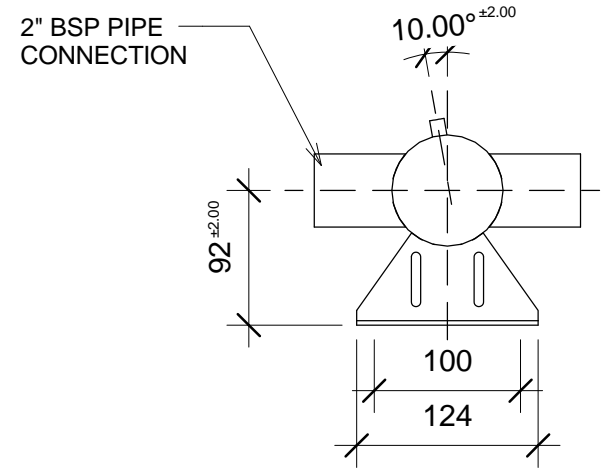
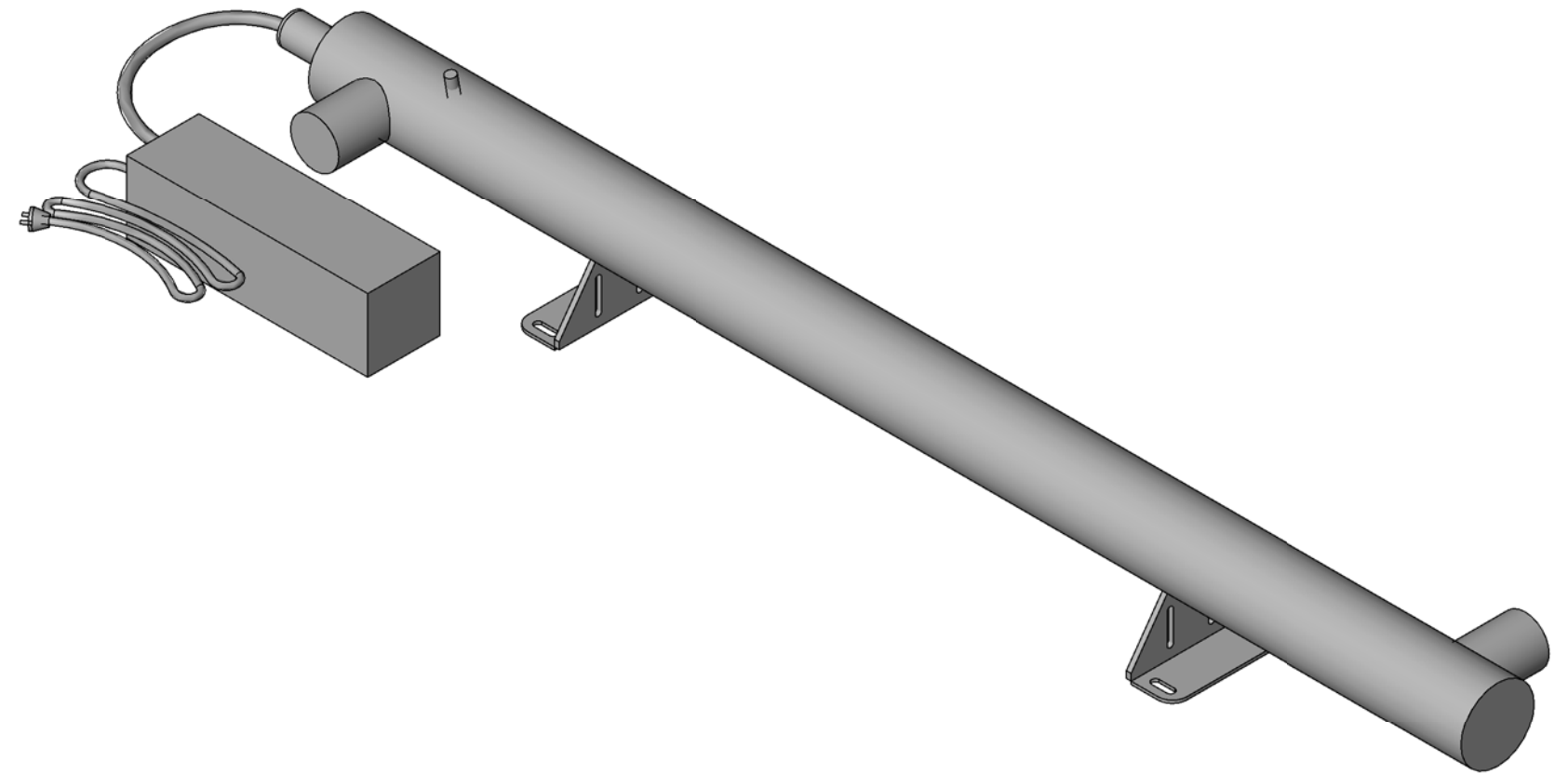
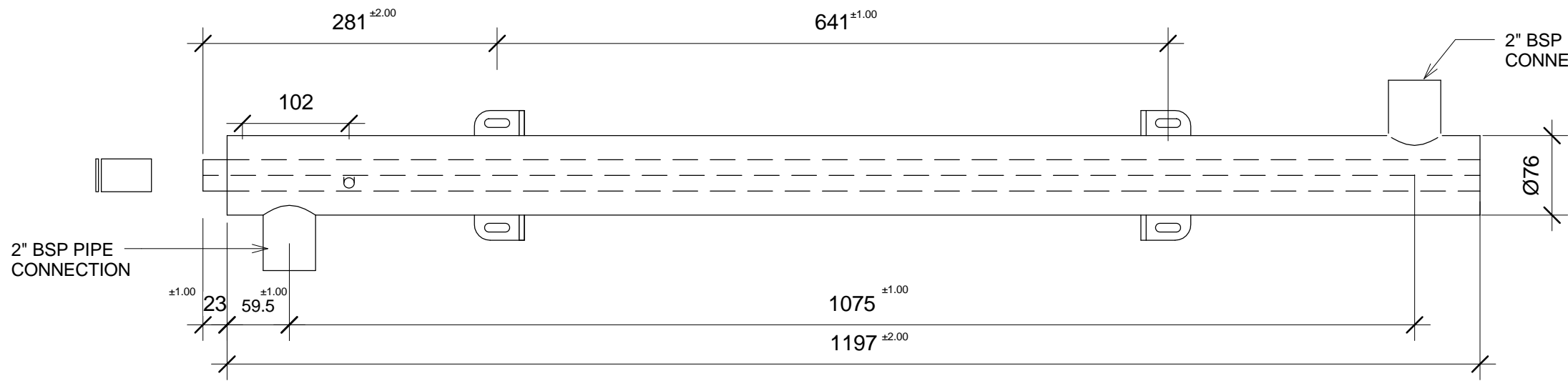

DDUV300 - UV steriliser notes

- Max flow rate - 300 l/min
- Power supply - AC 240 V 50 Hz
- Max operating pressure - 1000 kPa
- Inlet - R2" (50mm)
- Outlet - R2" (50mm)

MATERIAL		DRAWN	DAP	Rinnai Australia Pty Ltd	
TOLERANCE - UNLESS STATED		DATE	17/07/12		
0.±1.0	0.00 ±0.1	APPROVED		Title DDUV300 - UV STERILISER	
0.0 ±0.5	Angular ±1				
FINISH:		DO NOT SCALE DRAWING		Weight	Drawing Number(PART NO) RA-17-07-12-001
					Revision