

# Rinnai

## OPERATION & INSTALLATION MANUAL Power Flued Flamefire Gas Space Heaters RHFE-950ETR & RHFE-1250ETR

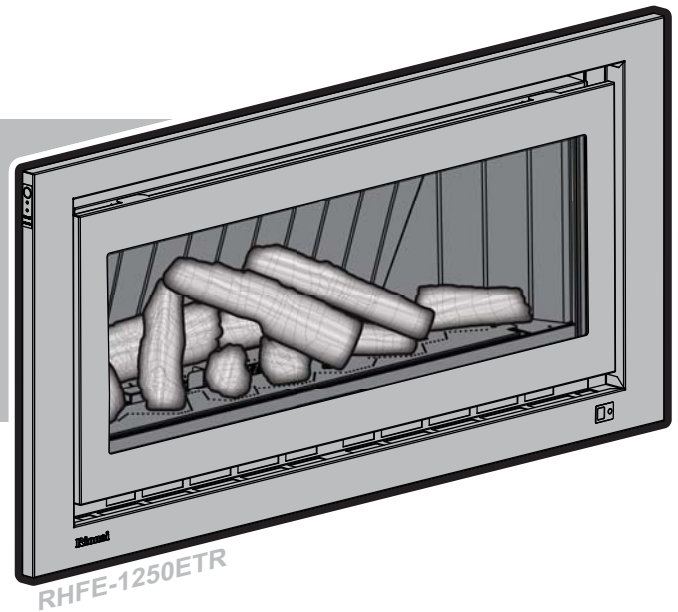
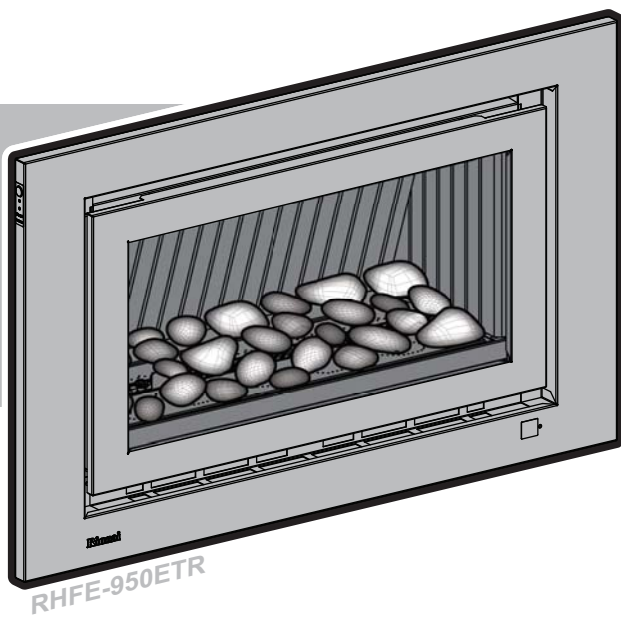

### This appliance shall be installed in accordance with:

- Manufacturer's Installation Instructions
- Current AS/NZS 5601 AS/NZS 3000
- Local Regulations and Municipal Building Codes including local OH&S requirements

This appliance must be installed, maintained and removed by an Authorised Person.

For continued safety of this appliance it must be installed and maintained in accordance with the manufacturers instructions.



The Australian  
Gas Association  
All Rinnai gas products  
are A.G.A. certified.



N10378

**Congratulations on the purchase of your Rinnai RHFE-950ETR or RHFE-1250ETR Flamefire.  
We trust you will have many years of comfort and enjoyment from your appliance.**

**BEFORE PROCEEDING WITH THE OPERATION OR INSTALLATION OF YOUR NEW HEATER  
PLEASE READ THIS MANUAL THOROUGHLY AND GAIN A FULL UNDERSTANDING OF THE  
REQUIREMENTS, FEATURES AND OPERATION OF YOUR NEW APPLIANCE.**

# OPERATION MANUAL

<b>BEFORE YOU START</b> .....	<b>4</b>
INSTALLATION REQUIREMENTS .....	4
CERTIFICATION .....	4
FLUE INSTALLATION MANUAL .....	4
CARTON CONTENTS / ITEM CHECKLIST .....	4
<b>ABOUT THE RHFE-950ETR / RHFE-1250ETR SPACE HEATER</b> .....	<b>5</b>
GENERAL DESIGN LAYOUT .....	5
REMOTE CONTROL GENERAL LAYOUT .....	6
REMOTE CONTROL DISPLAY .....	7
FEATURES .....	7
UNPACKING THE APPLIANCE: .....	7
<b>SAFETY</b> .....	<b>8</b>
<b>BASIC HEATER OPERATION</b> .....	<b>10</b>
GENERAL NOTES ABOUT IGNITION .....	10
OPERATION WITHOUT THE REMOTE CONTROL (AUTOMATIC MODE) .....	10
OPERATION WITH THE REMOTE CONTROL .....	10
TURNING ON THE POWER .....	11
USING THE REMOTE CONTROL TO OPERATE THE HEATER .....	11
FLAME FUNCTION .....	12
<b>PROGRAMMED HEATER OPERATION</b> .....	<b>13</b>
PROGRAMMING THE CLOCK AND TIMERS .....	13
USING THE TIMERS .....	13
PRE-HEAT .....	14
USING THE OVERRIDE FUNCTION .....	14
USING THE EXTRA LOW FUNCTION .....	14
THE LOCK FUNCTION .....	14
<b>CARE AND MAINTENANCE</b> .....	<b>15</b>
CLEANING .....	15
FILTERS .....	15
WARM AIR VENT .....	15
GENERAL HEATER CHARACTERISTICS .....	16
SERVICE .....	16
TROUBLE SHOOTING CHECKLIST .....	17
ERROR CODES .....	17
<b>INSTALLATION MANUAL</b> .....	<b>18</b>
<b>CONTACT INFORMATION</b> .....	<b>32</b>

# BEFORE YOU START

## INSTALLATION REQUIREMENTS

This heater must be installed by an authorised person. The installation must conform to local regulations. The installation must also comply with the instructions supplied by Rinnai.

Service and removal must be carried out by an authorised person.

## CERTIFICATION

The Rinnai RHFE-950ETR / RHFE-1250ETR has been certified by the Australian Gas Association.

The AGA Certification Number is shown on the appliance dataplate. (Located on the top right hand corner of the right hand side panel).

No parts or functions should be modified or permanently removed from the heater.

Please keep these instructions in a safe place for future reference.

## FLUE INSTALLATION MANUAL

These instructions are to be used in conjunction with the Rinnai "Power Flued Flamefire Space Heater Co-axial Flue System Installation Manual" supplied with flue kits ASPDFK or ASPKIT03.

## CARTON CONTENTS / ITEM CHECKLIST

The components for RHFE-950ETR / RHFE-1250ETR Flamefires are supplied in 3 separate cartons, the following tables list which components are in each carton. Ensure that the components listed are present before proceeding with the installation.

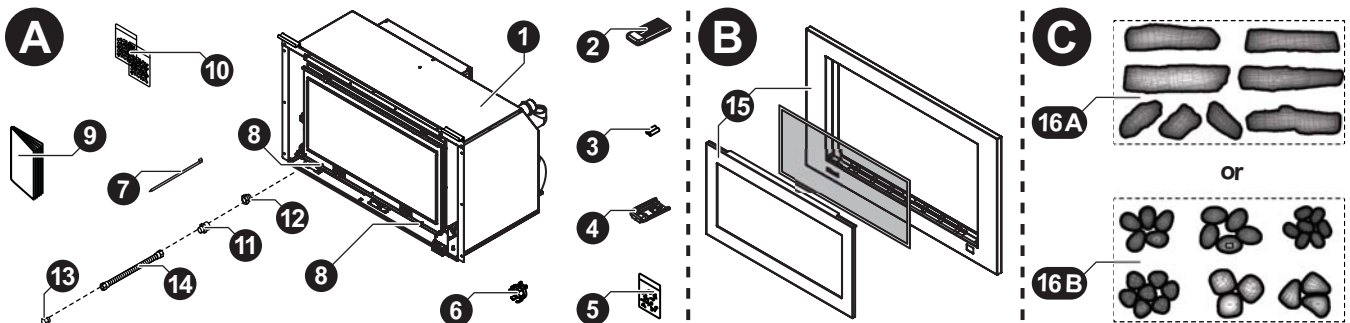

Component Descriptions (Image of RHFE-950ETR shown)		Carton Contents		
		A Engine	B Fascia	C Burn Media
1	RHFE-950ETR Engine only / RHFE-1250ETR Engine and dress guard.	●		
2	Remote Control.	●		
3	1.5V AAA Batteries (x2)	●		
4	Remote Control Mounting Bracket.	●		
5	Fixings: Screw 8x1 Truss PH ZP (x2), Screw M4 x 20 Pan Phil Zinc (x1).	●		
6	Flue Exhaust Lock (see Co-axial Flue Installation Manual for details).	●		
7	Cable Tie 300mm.	●		
8	Fascia Mounting Screws (x2 pre-installed in the engine fascia mounting brackets).	●		
9	This Operation and Installation Manual.	●		
10	Ceramic Granules (x2 Bags RHFE-950ETR/ x3 Bags RHFE-1250ETR use with Log set inst).	●		
11	1/2" BSP x 5/8" UNF Flare Brass Adaptor (x1).	●		
12	1/2" Flare Brass Nut (x1).	●		
13	5/8" UNF Flare Brass Plug (x1).	●		
14	Semi-rigid Stainless Steel gas pipe with 5/8" connections (x1).	●		
15	RHFE-950ETR - Fascia and dress guard / RHFE-1250ETR - Fascia only.		●	
16	A. Ceramic Log Set (RHFE-950ETR x8 logs, RHFE-1250ETR x10 logs).			●
16	B. Ceramic Stone Set (RHFE-950ETR x30 stones, RHFE-1250ETR x40 stones).			●

# ABOUT THE RHFE-950ETR / RHFE-1250ETR SPACE HEATER

## GENERAL DESIGN LAYOUT

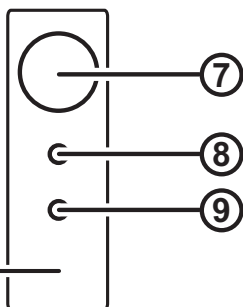
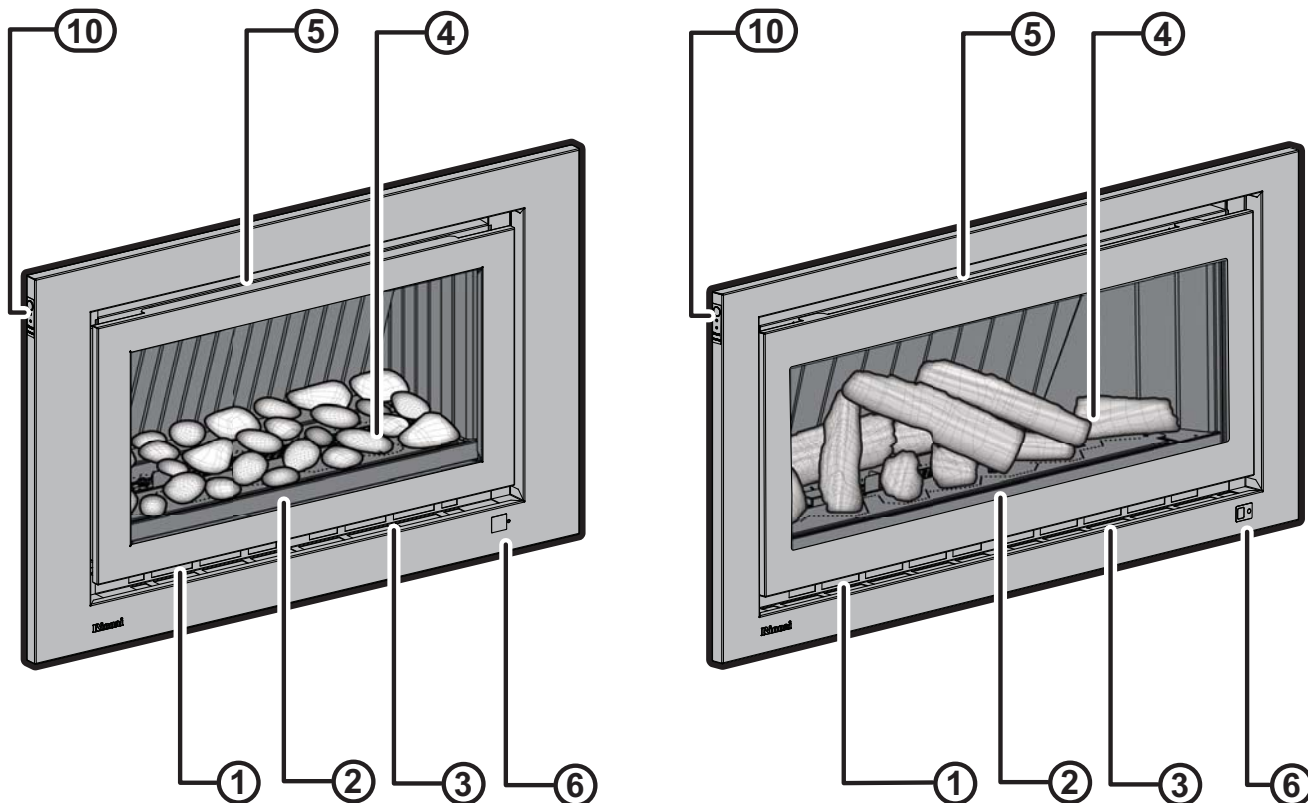

CONTROL PANEL DETAIL



- |  |  |  |
|--|--|--|
| <p><b>1</b> <b>ERROR DISPLAY</b><br/>Displays error codes (located behind fascia and viewed through grill).</p> <p><b>4</b> <b>BURNER MEDIA</b><br/>Both models have the option of either logs or stones as burner media.</p> <p><b>7</b> <b>ON / OFF BUTTON</b><br/>Turns the heater On or Off.</p> | <p><b>2</b> <b>GLASS FLAME WINDOW</b></p> <p><b>5</b> <b>WARM AIR DISCHARGE VENT</b></p> <p><b>8</b> <b>OPERATION INDICATOR</b><br/>Indicates operation status</p> <p><b>10</b> <b>CONTROL PANEL</b></p> | <p><b>3</b> <b>ROOM AIR RETURN / INLET FILTERS</b><br/>Dust filter meshing is fixed to the inlets of the room air return.</p> <p><b>6</b> <b>RECEIVER WINDOW / BLOCKAGE INDICATOR</b><br/>Remote control receiver/ Indicator for filter/louvre blockages.</p> <p><b>9</b> <b>TIMER INDICATOR</b><br/>Indicates timer program status.</p> |
|--|--|--|

REMOTE CONTROL GENERAL LAYOUT

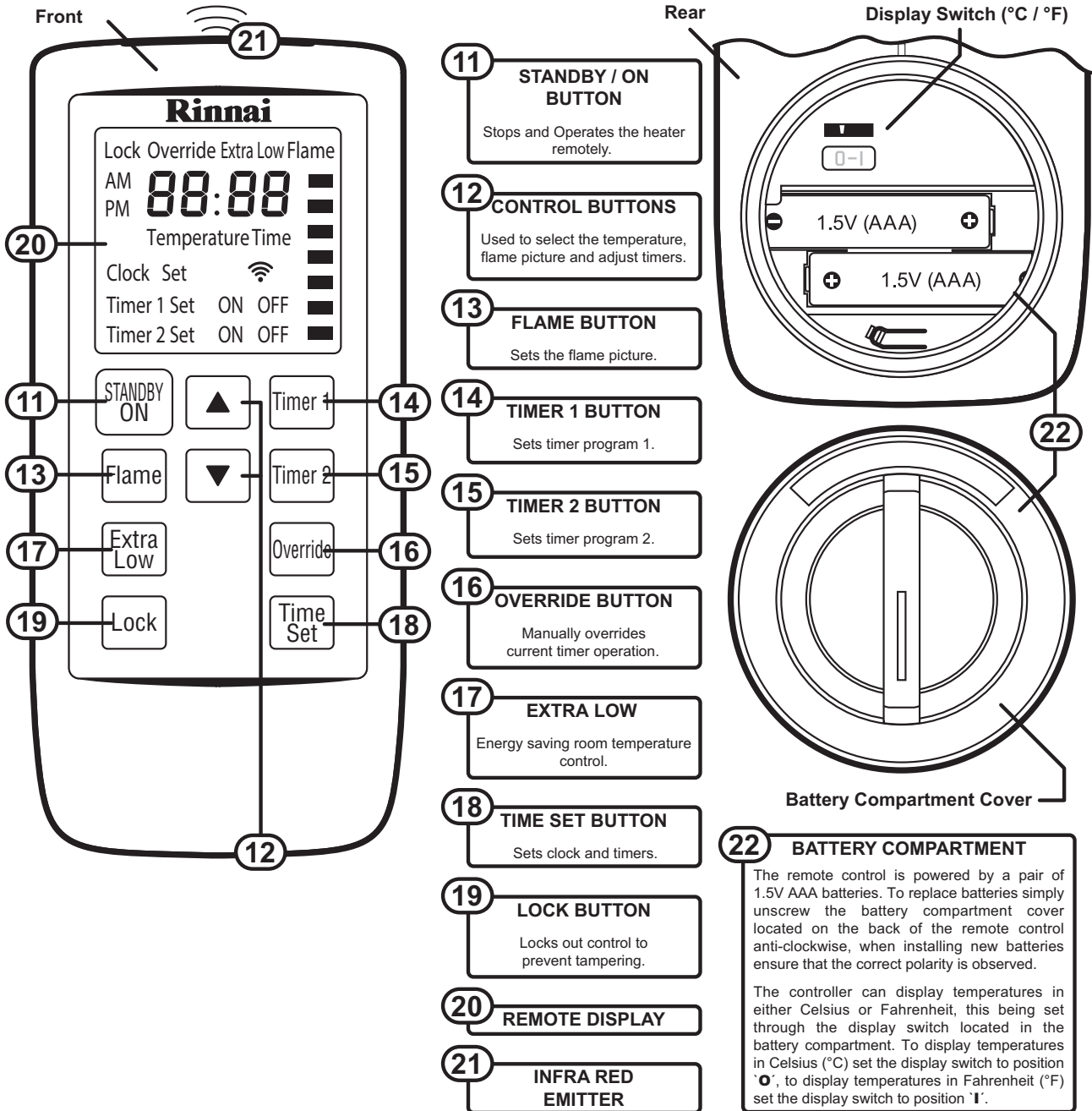

NOTE

- Use 2 x 1.5V AAA batteries. NEVER mix old and new batteries.
- Remove batteries if the remote control is not going to be used for a long period. This will help avoid damage from leaking batteries.
- When using “Timers” press “Override” to activate remote control functions.
- If the heater is operating in “Override” mode, using the STANDBY/ON button will cancel any future timer operations, these will have to be reset manually.
- Some fluorescent lights may interfere with the transmission of remote control signals, in this case changing the position from which you are operating the remote control may help.
- Avoid leaving the remote control in direct sunlight and do not place it close to the warm air discharge louvres of the heater.
- Avoid dropping the remote control or getting it wet.

## REMOTE CONTROL DISPLAY

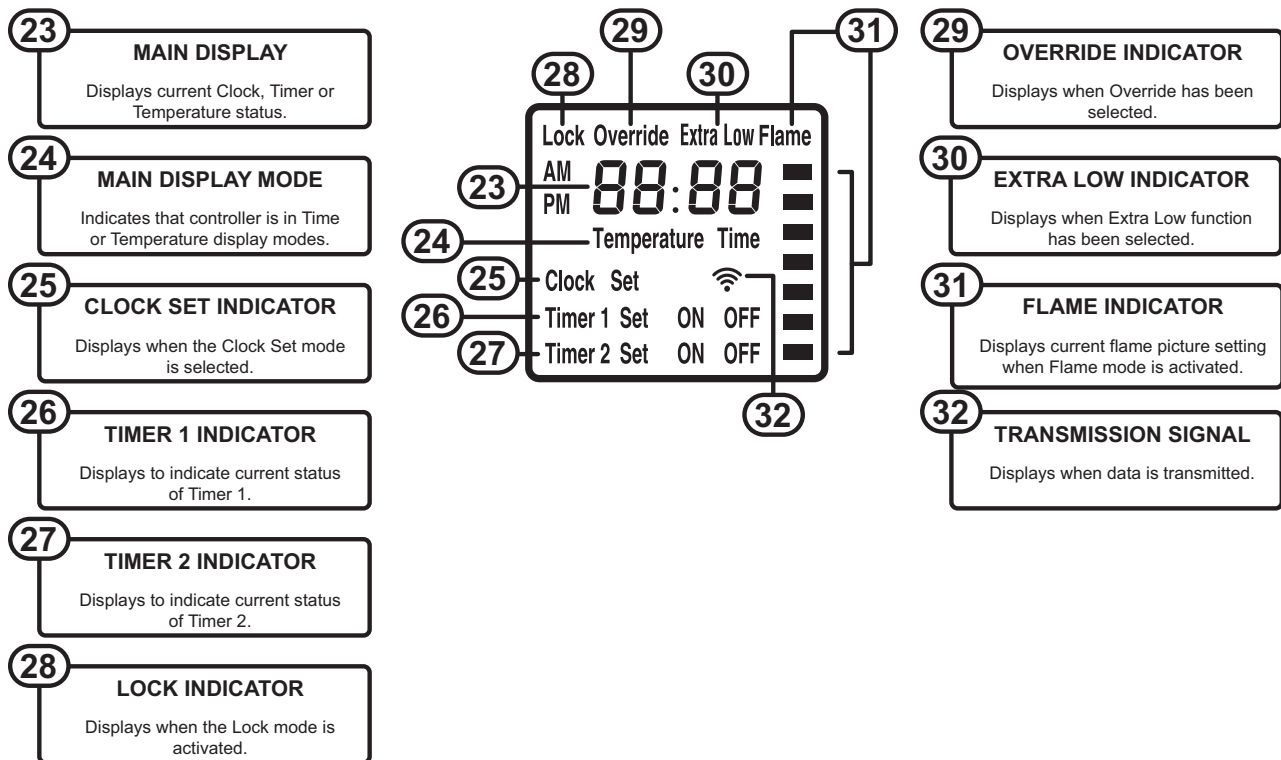

## FEATURES

- **Room Sealed:** Air for combustion is taken from the outside and the flue products are exhausted to the outside. This means heater operation has no effect on the composition and quality of air in the room.
- **Push Button Ignition:** Only one touch of the STANDBY/ON switch is all that is required to operate the heater.
- **Lock:** When the Lock function is activated all controls other than the STANDBY/ON switch will be locked. Deactivating the lock releases the controls. If the lock is activated when the appliance is in STANDBY, all functions will be locked.
- **Memory:** The heaters micro-computer records preset temperatures, timer programming, and operational modes. Even in the event of a power failure, the need for reprogramming is minimised.
- **Dual Timer:** The Dual Timer allows you to program the appliance to operate for two separate periods each day. Once programmed the heater can then be controlled by selection of the Timer 1 and or Timer 2 functions.  
The Dual Timer feature means that you can "Set and Forget" your heater. It will turn itself ON or to STANDBY at the times you have programmed until you cancel the Timer program.
- **Pre-Heat:** This function automatically operates the appliance before the programmed ON time of the Timer, in order to heat a room to the pre-set temperature by the programmed ON time.
- **Remote Control:** Full function cordless remote for the convenience of operating the heater from a distance.
- **Extra Low Function:** The Extra low function is an energy saving feature designed to control the room temperature economically. If the room temperature continues to rise above the set temperature on thermostat the main burner will turn down to its lowest setting. When the room temperature requires further heating the heater will automatically re-ignite to warm the room.

## UNPACKING THE APPLIANCE:

Check for damage and missing parts. If the heater is damaged or missing any parts, contact your supplier for advice. Before installing the appliance, check it is labelled for the correct gas type (see label on top rear of heater). Refer to local gas authority for confirmation of gas type if you are in doubt.

# SAFETY



## DO NOT MODIFY THIS APPLIANCE.

Failure to comply with these instructions could result in a fire or explosion, which could cause serious injury, death or property damage.

Improper installation, adjustments, service or maintenance can cause serious injury, death or property damage. Such work must be performed by an authorised person.



- The appliance must be installed in accordance with the local gas and electrical authority regulations.
- For information on gas consumption, refer to the data plate on the appliance.
- This appliance must not be installed where curtains or other combustible materials could come into contact with it. In some cases curtains may need restraining.

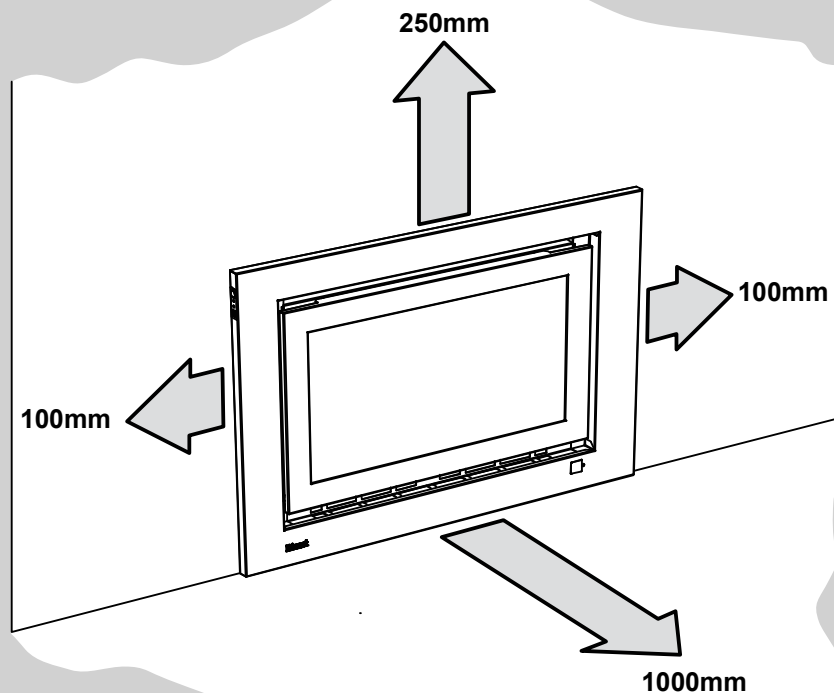

The above diagram shows the clearances required around this heater whilst in operation .

- Heat emanating from the front of this appliance may over time affect the appearance of some materials used for flooring such as carpet, vinyl, cork or timber. This effect may be amplified if the air in the room contains cooking vapours or cigarette smoke. To avoid this possibility, it is recommended that a mat be placed in front of the appliance, extending at least 750 mm in front of it.
- The appliance is not intended for use by young children or infirm persons without supervision.
- Young children should be supervised to ensure they do not play with the appliance.
- If the supply cord is damaged or requires replacing, it must be replaced by the manufacturer or the manufacturer's agent or similarly qualified person in order to avoid a hazard.



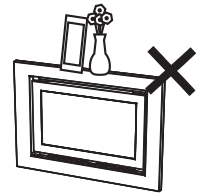
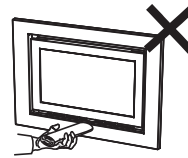
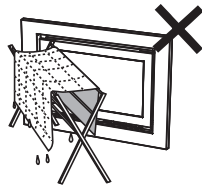
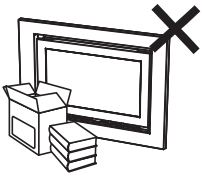

**DO NOT** restrict the warm air discharge by placing articles in front of the heater. This appliance must not be used for any purpose other than heating.

**DO NOT** allow anyone to post articles through the louvres or let flammable and combustible materials to come into contact with the heater.

**DO NOT** place articles on or against this appliance, on the heaters top panel or obstruct the auto overheat discharge vent.

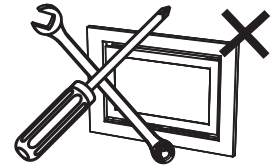
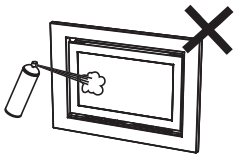

**DO NOT** spray aerosols in the vicinity of this appliance whilst the heater is operating. Most aerosols contain flammable gas, which can be a fire hazard if used near the heater when it is in use.

**DO NOT** store flammable materials near this appliance.

**DO NOT** modify this appliance.

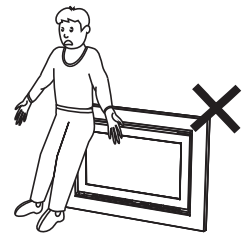
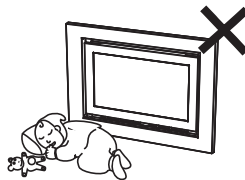
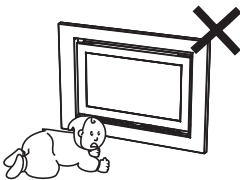

Young children should be supervised at all times. Hand or body contact with the warm air discharge louvres and glass must be avoided.

**DO NOT** allow young children or the infirm to sleep directly in front of the heater while in operation.

**DO NOT** allow anyone to sit on or lean against the appliance.

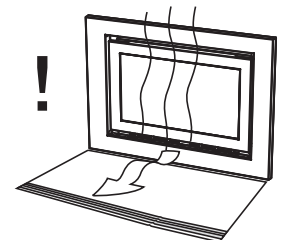
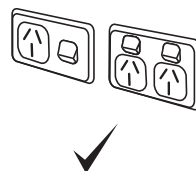
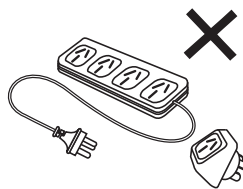
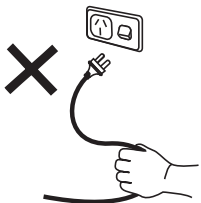

**DO NOT** unplug the heater while it is in operation or while the fans are still cycling. Unplugging the heater will cause any timer operation to stop. Timer programs are stored in the memory of the remote control.

A dedicated 230~240V 50Hz 10 Amp power point must be used with this appliance. **DO NOT** use power boards or double adaptors to operate this appliance. The appliance **MUST NOT BE** located below a power Point.

Heat emanating from the front of this appliance may over time affect the appearance of some materials used for flooring such as carpet, vinyl, cork or timber. This effect may be amplified if the air in the room contains cooking vapours or cigarette smoke. To avoid this possibility, it is recommended that a mat be placed in front of the appliance, extending at least 750 mm in front of it.

# BASIC HEATER OPERATION

## GENERAL NOTES ABOUT IGNITION

This appliance has a sealed combustion chamber that requires purging before gas is allowed to flow and the ignition sequence begins. As a result the combustion fan starts several seconds before there are any signs of ignition. The normal ignition sequence is as follows:

1. When the On/Off button ⑦ is pressed the Operation Indicator LED ⑧ will glow 'BLUE' and Combustion fan will rotate to purge the system.
2. Ignition sparker operates.
3. As soon as a spark is sensed, gas will flow to the main burner.
4. When the main burner has established the heater will automatically modulate between burner settings to achieve and maintain the default set temperature of 22°C.

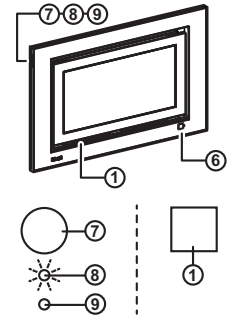

**When using the heater for the first time or after long periods of non use, ignition may not occur the first time it is operated due to air in the gas pipes.**

**If ignition does not occur within approximately 60 seconds the appliance will attempt to re-light, however if ignition continues to fail the unit will cease operation automatically. Try operating the heater again if this occurs.**

**The heater may make noises after ignition or extinction. This is due to expansion and contraction of the internal components and is normal page 16 for details.**

**The heater will not ignite if the ON/OFF button is pressed straight after extinction. After approximately 20 seconds "purge period" has passed the unit will automatically go into ignition mode.**

## OPERATION WITHOUT THE REMOTE CONTROL (AUTOMATIC MODE)

The remote control stores the clock, timer and temperature settings for the heater. The heater can be operated and stopped without the remote control by simply using the On/Off button ⑦ on the left hand side of the heater. Operation in this manner is known as automatic mode. In automatic mode the default set temperature is 22°C. For operation in other modes the remote control must be used.

## OPERATION WITH THE REMOTE CONTROL

For the remote control functions to be available, the heater must be switched between standby and off using the remote control.

The remote control emits an Infra Red (IR) signal and must be aimed at the receiver unit located on the bottom right hand corner of the front panel ⑥. The normal operating range is approximately 5 metres, up to an angle of approximately 40 degrees to the horizontal. This range may vary depending on the position of the installation and the strength of the remote controller batteries. The remote control transmits information to the heater whenever a button is pressed except as follows:

1. When the remote control display is de-activated and any button is pressed to restore the display
2. When the lock function is activated

When the timers are being set, timer information is transmitted only when the 'Time Set' button is pressed.

Signal transmissions are confirmed by a brief illumination of the Transmission Signal Indicator ③② on the Remote Display ②① and at the heater the Remote Control Indicator ⑥ will flash and a beep will sound to confirm that the settings have been received.

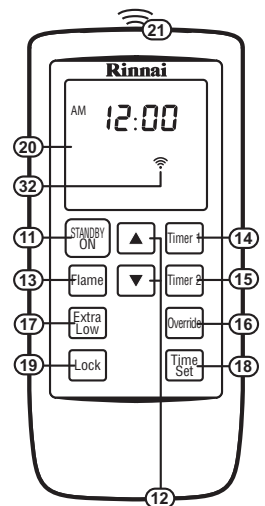

**When the remote control is not used for a period of approximately 5 seconds the display will then default to stand-by mode, displaying only the time.**

**To re-activate the remote control press any button on the keypad. This returns the display to the previous mode. No information is transmitted from the controller to the heater when re-activating the display.**

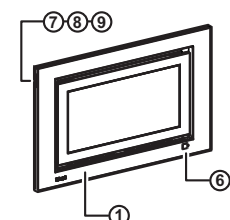

**TURNING ON THE POWER**

Press the On/Off button (7) located on the heater control panel once. The Operation Indicator (8) will illuminate and glow 'BLUE' and the ignition process will commence.

The heater will continue to operate in the automatic mode to achieve and maintain a default temperature setting of 22°C until an alternate command is received from the remote control.

If the main power is disrupted whilst the heater is operating, once the power is restored the heater will go into power failure mode.

This is indicated by a pair of flashing zeros in the Error Display (1) window and a 'RED' flashing Operation Indicator (8).

To reset the heater, press the On/Off button (7) once. Press the STANDBY/ON button (11) a second time to switch the heater on.

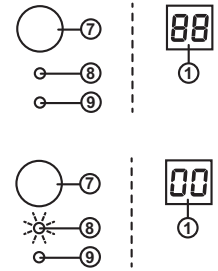

To operate the heater in automatic mode without using the remote control, press the main power switch ON the heater OFF and then on again. The heater will operate with a default set temperature of 22°C.

If the heater is turned off using the On/Off button (7) on the heater control panel when it is turned back on it will lose all timer and clock settings until the remote control is used to re-transmit this information.



DO NOT unplug the main power supply to extinguish the flames as this may cause damage. The convection fan is required to continue operation for several minutes after extinction of the flames to assist cooling.

**USING THE REMOTE CONTROL TO OPERATE THE HEATER**



The remote control uses 2 x 1.5V AAA batteries (NEVER mix old and new batteries). Remove batteries if the remote control is not going to be used for a long period. This will help avoid damage from leaking batteries.

To replace batteries simply unscrew the battery compartment cover located on the back of the remote control anti-clockwise. When installing new batteries ensure that the correct polarity is observed, the polarity is engraved into the battery compartment (see the illustration on page 6).

**Turning The Heater On**

When the heater is in standby mode (Operation Indicator (8) illuminated 'RED') pressing the STANDBY/ON button (11) will start the ignition sequence and the Operation Indicator (8) will glow 'BLUE' to indicate that the heater is now in operation.

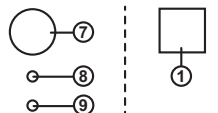

**Turning The Heater To Stand-By**

Press the STANDBY/ON button (11). This will extinguish all flames and the Operation Indicator (8) will glow 'RED' to indicate the appliance is now in stand-by mode.

**Adjusting The Temperature**

When in automatic mode, pressing the Up and Down buttons (12) will change the pre-set temperature by increments of 1°C with each press.

"Temperature" (24) will be displayed to confirm that the function has been initiated. The Remote Display will show the selected temperature (23) in degrees °C.

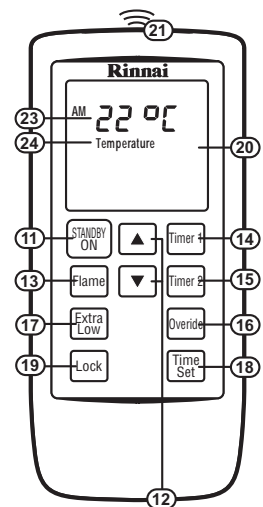

**The Temperature Can Be Pre-set To:**

- A.L (Low) – Continuous combustion on low.
- B.16°C ~ 26°C (in 1°C steps) – Thermostatic control to pre-set temperature selected. Combustion rate varies to maintain the selected temperature.
- C.H (High) – Continuous combustion on high.

**FLAME FUNCTION**

The flame function is used to select a desired flame picture and overrides the automatic mode. There are seven separate flame picture settings available.

1. While the heater is in operation press the Flame button (13) once to activate this function. The heater will automatically default to the last used flame picture setting.
2. "Flame" and a series of seven short bars (31) (one bar for each of the seven flame picture settings) will be displayed to show that the flame function is in operation.
3. Use the Up and Down buttons (12) to select the desired flame picture. The number of bars illuminated correspond to the flame picture setting selected.

To return to automatic mode press the Flame button (13) a second time.

 **Should the room temperature reach 40°C whilst the flame function is activated the heater will switch off automatically. This is a safety feature.**

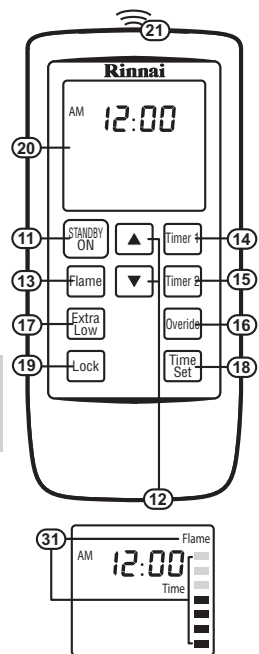

# PROGRAMMED HEATER OPERATION

## PROGRAMMING THE CLOCK AND TIMERS

The clock must be set before the timers will operate. The clock may need to be re-set whenever the remote control batteries are changed.

This heater has two timers which allow the heater to start and stop during two distinct periods each day.

The set temperature during timer operation is the temperature which was selected when the heater was last used.

### Clock Setting

1. Press the Time Set button (18) once. "Clock Set" (25) will be displayed to confirm that the function has been initiated. The Remote Display will show "AM 12:00" (23).
2. Use the Up and Down buttons (12) to set the desired "AM" or "PM" clock time. Then press the Time Set button (18) once.



**If you do not want to set the timers at this point then press the Time Set (18) button 4 more times until the display returns to the time.**  
**If there is no button pressed for approximately 90 seconds then the screen will deactivate and any settings that have not been transmitted will be lost.**

### Timer Setting

3. "Timer 1 Set ON" (26) and "AM 06:00" (23) will be displayed. Use the Up and Down buttons (12) to set the desired "AM" or "PM" "ON" time. Press the Time Set button (18) once.
4. "Timer 1 Set OFF" (26) and "AM 09:00" (23) will be displayed. Use the Up and Down buttons (12) to set the desired "AM" or "PM" "OFF" time. Press the Time Set button (18) once.
5. To set-up Timer 2 repeat steps 3. and 4 above or just press the Time Set button (18) three times to exit the timer set-up.
6. The set On/Off timers will be displayed briefly to confirm settings.

When the programs have been received the Remote Display will revert to Time mode (23) and (24).



**After battery replacement the clock and timers may need to be re-programmed.**

## USING THE TIMERS

Prior to using timers ensure that the desired temperature has been set. See ADJUSTING THE TEMPERATURE on page 11.

1. One or both Timers can be used. While the heater is in operation to start Timer 1 press the Timer 1 button (14). To start Timer 2 press the Timer 2 button (15).

The display briefly shows the status of each Timer (e.g. Timer 1 ON Timer 1 OFF). If the current time is outside those programmed the heater will go in to stand-by mode and the Timer Indicator (9) will glow 'Green'. Each active timer (26) / (27) are also shown on the Remote Control Display (20).

2. To turn the Timer(s) off simply press the relevant Timer button again. The heater will return to stand-by mode and the Operation Indicator (8) will glow 'RED', if there are no timers set the Timer Indicator (9) will go out and the timers are no longer be shown on the Remote Control Display (20).



**When operated by the Timer(s) the Flame Function is not available. If desired the flame picture can be controlled by raising or lowering the set temperature.**

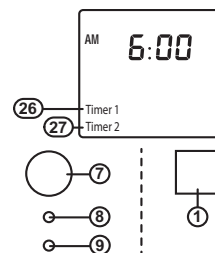
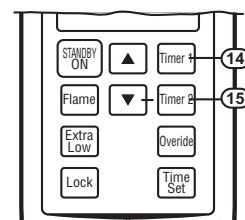
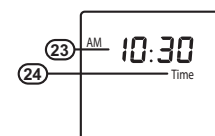
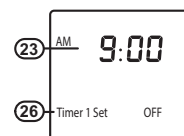
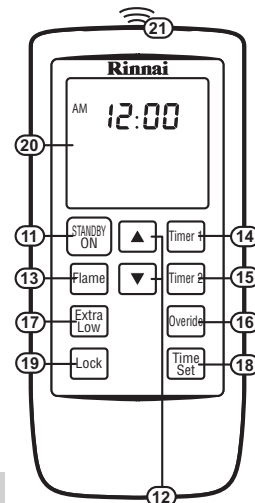

**PRE-HEAT**

This function operates automatically in conjunction with the Timers. When a Timer is selected, the heater may operate anywhere within an hour prior to the programmed ON Time.

This function is called Pre-heat as it ensures the room reaches the desired temperature by the programmed ON time.

This is achieved by sensing the rooms temperature one hour prior to start.

The difference in room and set temperatures at the time of sensing the room temperature determines exactly how long before the programmed ON time the micro-computer will ignite the burner.

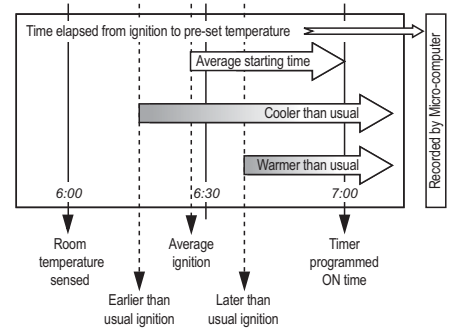

**USING THE OVERRIDE FUNCTION**

This function is used to manually override Timer programmed operation.

When the Override button (16) is pressed "Override" (29) will be displayed to confirm that the function has been selected. Whilst in Override mode all remote control functions except for the flame function are available until the next Timer event.

To return to Timer programmed operation press the Override button (16) a second time.

If the STANDBY/ON button (11) is pressed during Override operations the heater will revert to STANDBY and the Timer programs will be cancelled.



**USING THE EXTRA LOW FUNCTION**

The Extra Low function is useful in situations when the room temperature keeps rising even when the heater is on the lowest heat setting.

**Extra Low Function 'OFF'**

When the room temperature reaches the preset temperature with the Extra Low function 'OFF', the heater continues to operate with the main burner on low to provide a flame picture with minimal heat output. In some cases this may still cause the room to become warmer than desired.

**Extra Low Function 'ON'**

When the room temperature exceeds the preset temperature with the Extra Low function 'ON' the burner will reduce to an extra low setting. The burner will return to normal to maintain the set temperature.

1. To switch the Extra Low function 'ON', press the Extra Low button (17) once.  
"Extra Low" (30) will be displayed to confirm that the function has been selected.
2. To switch the Extra Low function 'OFF', press the Extra Low button (17) again.

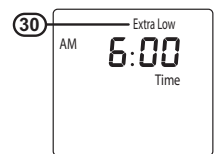
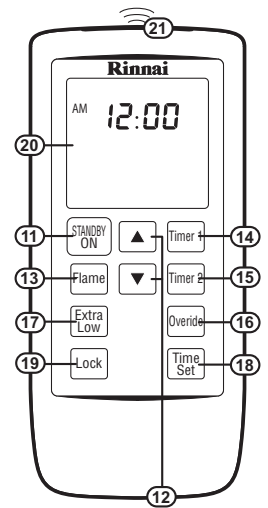

**THE LOCK FUNCTION**

By pressing the Lock button (19) all the functions of the remote control will be locked with the exception of the STANDBY/ON button (11) for the purpose of turning the heater to STANDBY only.

The Remote Control Display (20) will show "Lock" (28) in the top left hand corner.

To cancel the Lock function hold down the Lock button (19) for 3 seconds.

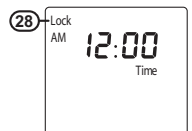

# CARE AND MAINTENANCE

## CLEANING

Your heater needs very little maintenance, however the following information will help you keep it looking good and working efficiently.



- **Unplug electrical cord before cleaning.**
- **DO NOT USE SOLVENTS. All parts of the heater and remote control can be cleaned using a soft, damp cloth and a mild detergent.**
- **DO NOT attempt to clean the heater while the appliance is hot or operating.**

## FILTERS

The filter meshing for this appliance is fixed to the inlets of the room air return ③.

The build up of dust or other particles on these filter strips reduces the air flow through to the heater which in turn reduces heater's efficiency and can lead to the appliance shutting down.

### Filter Care

Filters require cleaning regularly during the heating season to prevent these unnecessary cut-outs.

### Cleaning filter strips:

Clean any dust and other debris from both faces of the filters with either a vacuum cleaner, a soft dry cloth or a soft brush. **NEVER** attempt to clean filters with water.

### Heater shut down due to filter blockages

**DO NOT** wait for the Filter Blockage Indicator to come on before cleaning filters.

**DO NOT** continue to use the heater once this Indicator is flashing.

When an obstructive build up is detected the Blockage Indicator LED which is located above the Receiver Window ⑥ will begin to flash RED to let you know that there is a problem.

Once the Indicator is flashing if no action is taken the heater will eventually shut down to avoid overheating and a fault code of 14 will be displayed in the Error Display ⑩ window.

### Returning the appliance to normal operation after a shut down

To restore to normal operation after a filter blockage shut down do the following:

1. Press the On/Off ⑦ button once to turn off the heater.
2. Remove obstruction (see "Filter Care" on page 15).
3. Press the On/Off ⑦ button once to turn the heater back on.
4. Use the remote control to resume normal heater operation.

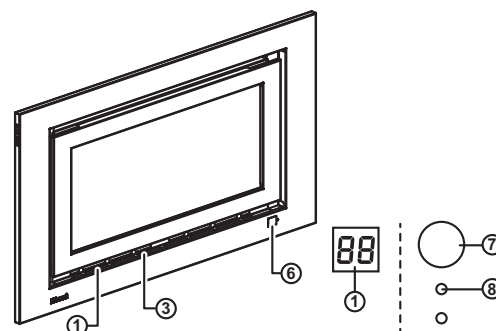
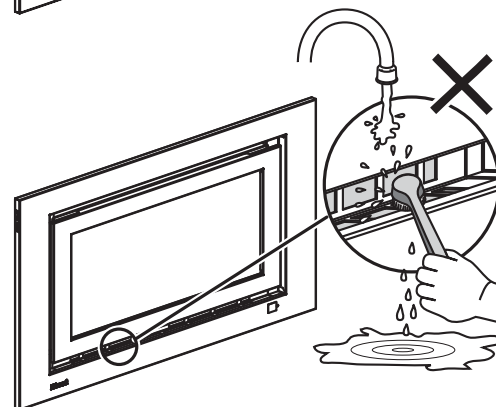
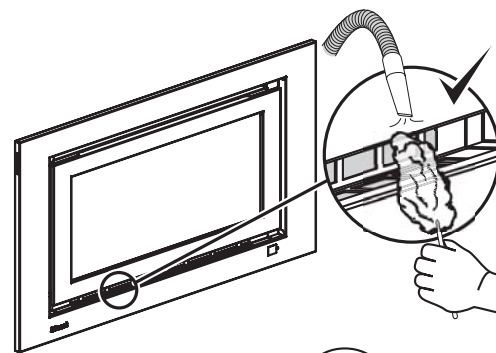
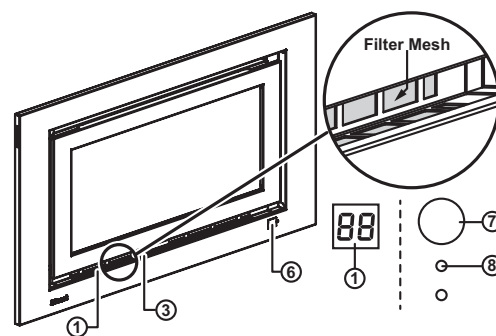

## WARM AIR VENT

It is important that the Warm Air Discharge Vent ⑤ be kept clear of any obstructions as this will cause your heater to operate less efficiently.

When an obstruction is detected the Blockage Indicator LED which is located next to the Receiver Window ⑥ will illuminate RED and the combustion state reduces to front burner, low operation only.

To restore normal operation remove the obstruction and use the remote control to resume normal heater operation.

**GENERAL HEATER CHARACTERISTICS**

Before asking for a service call please check the following table as these characteristics are part of the normal operation of the appliance and do not indicate a fault.

CHARACTERISTIC	→	EXPLANATION
<b>At ignition:</b>		
Warm air does not start when the burner lights.	→	The room air fan is started automatically after a short delay. This is to allow the heat exchanger to warm up, helping to avoid cold draughts.
Smoke or strange smells are produced on the first start up operation after installation.	→	This is caused by grease, oil or dust on the heat exchanger when new. This will stop after a short time.
Sharp clicking noises at ignition, or when the unit thermostat modulates to a lower or higher setting, or shuts down.	→	This is simply expansion and contraction noise from the heat exchanger and is normal.
<b>During combustion:</b>		
Clunking noise when the thermostat operates	→	This is the sound of the solenoid gas valves opening and closing to regulate the gas flow and is normal.
<b>When the appliance is turned off:</b>		
Convection fan continues to run after turning off.	→	This is to remove residual heat from the heat exchanger and stops once the appliance cools.
<b>Other points:</b>		
Steam is discharging from the flue terminal.	→	High efficiency appliances tend to discharge water vapour on cold days. This is normal.
Heater does not start when the STANDBY / ON button is pushed, thermostat is on High (H).	→	Check that the appliance On / Off button is ON. Check Timer(s). Timer(s) programmes must be turned off or overridden for manual operation.
<b>Timer(s):</b>		
Timer(s) do not operate at set time.	→	Timer(s) may either be inactivated or incorrectly programmed. Please confirm Timer(s) are set correctly. See page 15 for correct Timer(s) operation.
Timer operates for a short period and then cuts out.	→	Room temperature may be higher than the set temperature. Increase set temperature if desired. Cancel the Auto Off function.

**SERVICE**

Rinnai recommend that this appliance and installation be inspected and serviced every 2 years.

If the power supply cord or any other component of the heater are damaged, they must be replaced by Rinnai or a suitably qualified person.

Any service or repair work should only be carried out by an authorised person. Rinnai has service and spare parts departments nationally, see back cover for contact details.



**Service calls for general cleaning, maintenance and wear and tear are not necessarily covered under the warranty. Service calls of this nature may be chargeable.**

**Faults caused by insufficient gas supply, gas quality, installation errors or operation errors are not covered by the Rinnai warranty. Refer to separate warranty booklet.**

**Appliances incorporating a live fuel effect and designed to operate with luminous flames may exhibit slight carbon deposition on burner media. Slight deposition is acceptable.**



### TROUBLE SHOOTING CHECKLIST

Use the following chart to help determine whether a service call is required, however if you are unsure about the way your heater is operating, contact Rinnai or your local agent.

Fault Condition	Probable Cause							Possible Remedy
		No Display on remote	No ignition or control panel indicators	Burners fail to ignite	Combustion stops during operation	Smell of gas	Remote control doesn't work	
Not plugged in or turned off.			●	●			●	Plug in power cord or press On/Off (7) button.
Mains power failure.			●	●	●			Use power failure reset procedure on page 11.
(Initial Install) Air in gas pipe.				●				Installer to purge air from gas supply.
Filter obstructed.					●			Remove and clean filters.
Gas escape.						●		Isolate gas supply, call Rinnai service, page 32.
On Timer set.							●	Use the Override as described on page 14.
Lock set.							●	Cancel Lock as described on page 14.
Gas supply turned off.				●	●			Turn gas supply on at the meter or cylinder.
Flat batteries.		●						Replace remote control batteries 2 x 1.5v (AAA).
Remote Control lock-up due to mis operations such as the remote signal being out of range, incorrectly aimed or obstructed.							●	Press the STANDBY/ON (11) button.

### ERROR CODES

Your Rinnai Flamefire is also fitted with self diagnostic electronics that monitor the appliance during start-up and operation.

Should a fault occur the Flamefire will shut down, the fault that has caused the shut down will be indicated by a pair of flashing digits in the Error Display (10) window and a 'RED' flashing Operation Indicator (8).

Refer to the table below for probable cause and the suggested remedy.

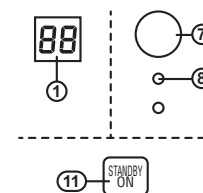

Code	Probable Cause	Suggested Remedy
00	Mains power failure	To reset the heater, press the On/Off (7) button twice or use the remote control and press the STANDBY/ON (11) button once for stand-by mode, press the STANDBY/ON (11) button a second time to set the heater to On.
11	Ignition failure	Check gas supply is turned on, switch the heater to Standby and then On again. <b>If the error persists a service call will be required.</b>
12	Incomplete combustion	Check gas supply is turned on, switch the heater to Standby and then On again. <b>If the error persists contact Rinnai.</b>
14	Filter Blockage / Overheat	Clean filters, <b>if the error persists a service call will be required.</b>
16	Room overheat	Lower room temp to below 40°C.
31	Room temperature sensor faulty	A service call will be required.
32	Overheat temperature sensor faulty	A service call will be required.
33	Overheat temperature sensor faulty	A service call will be required.
53	Spark sensor faulty	A service call will be required.
61	Combustion fan motor faulty	A service call will be required.
71	Solenoids faulty	A service call will be required.
72	Flame detection circuit fault	A service call will be required.
73	Communication error	A service call will be required.

# INSTALLATION MANUAL

<b>INSTALLATION GENERAL</b> .....	<b>19</b>
PRODUCT SPECIFICATIONS .....	19
APPLIANCE DIMENSIONS .....	19
<b>HEATER LOCATION</b> .....	<b>20</b>
ENCLOSURE REQUIREMENTS .....	20
WALL PENETRATION REQUIREMENTS .....	20
GAS SUPPLY .....	21
ELECTRICAL SUPPLY .....	21
MANTLE INSTALLATIONS .....	21
<b>FLUE INSTALLATION</b> .....	<b>22</b>
TYPES OF FLUE INSTALLATIONS .....	22
FLUE SYSTEM TRANSITION CASTING .....	22
FLUE TERMINAL LOCATION .....	23
<b>HEATER INSTALLATION</b> .....	<b>24</b>
1. UNPACKING THE APPLIANCE .....	24
2. CONNECTING THE FLUE SYSTEM .....	24
3. SECURING THE ENGINE .....	25
4. CONNECTING THE APPLIANCE TO THE GAS SUPPLY .....	25
5. INSTALLING CERAMIC BURNER MEDIA .....	25
6. COMMISSIONING .....	28
7. INSTALLING THE OUTER FASCIA PANEL .....	28
8. INSTALLING THE DRESS GUARD & INNER FASCIA PANEL .....	28
9. INSTALLATION AND COMMISSIONING CHECKLIST .....	29
10. INSTALLATION RECORD .....	29
11. FINAL CHECKLIST .....	29
<b>WIRING DIAGRAM</b> .....	<b>30</b>
<b>INSTALLATION NOTES</b> .....	<b>31</b>
<b>CONTACT INFORMATION</b> .....	<b>32</b>

# INSTALLATION GENERAL

## PRODUCT SPECIFICATIONS

Models: RHFE-950ETR & RHFE-1250ETR			
<b>General Description</b>	Inbuilt, Fan Exhaust, Balanced Flued, Convection Flame Fire with Electronic Temperature Control, Timer and Remote.		
<b>Gas Type</b>		<b>Natural Gas</b>	<b>Propane</b>
<b>Gas Input Rate (MJ/hr)</b>	Low	10	10
	High - Extended flue / High - Direct flue	31 / 34	32 / 34
<b>Gas Supply Pressure (kPa)</b>	Minimum / Maximum	1.13 / 3.50	2.5 / 3.50
<b>Gas Control</b>	Manual On/Off, 7 Heat Settings (Electric Touch Control) Remote IR		
<b>Output (kW)</b>	8.13		
<b>Heat-up area (m<sup>2</sup>)</b>	125 (cool areas)		
<b>Burners</b>	2 x Flame Burners		
<b>Gas Connection</b>	1/2" BSP flare		
<b>Guard</b>	Mesh Guard		
<b>Flue System</b>	Fan assisted, twin chamber coaxial flue system, provides air for combustion to the appliance and allows expulsion of combustion products to atmosphere. Results in 'room sealed' appliance.		
<b>Convection Fan</b>	Double drum 160mm x 180mm - 3 speed - Centrifugal		
<b>Combustion system</b>	Multi port burners x2 Forced exhaust		
<b>Burner Media</b>	Ceramic Logs with Granuals or Ceramic Stones with Granuals		
<b>Ignition system</b>	Continuous spark electronic ignition		
<b>Operation</b>	Push button electronic / Remote control		
<b>Safety Devices</b>	<ul style="list-style-type: none"> <li>- Overheat thermistor</li> <li>- Overcurrent Fuse</li> <li>- Air temperature Thermistor</li> <li>- Flame failure sensing system</li> <li>- Thermal Fuse</li> <li>- Spark Detector</li> </ul>		
<b>Heat Exchanger</b>	Negative pressure, 3 stage Hex		
<b>Installation type</b>	Inbuilt ONLY		
<b>Thermostat</b>	Thermostat in remote, wireless remote		
<b>Colours</b>	Fascia - Stainless Steel on Black / Fascia - Black on black		
<b>Weight - Engine only (kg)</b>	RHFE-950ETR	70	
	RHFE-1250ETR	100	

The manufacturer reserves the right to change or modify specifications without notice.

## APPLIANCE DIMENSIONS

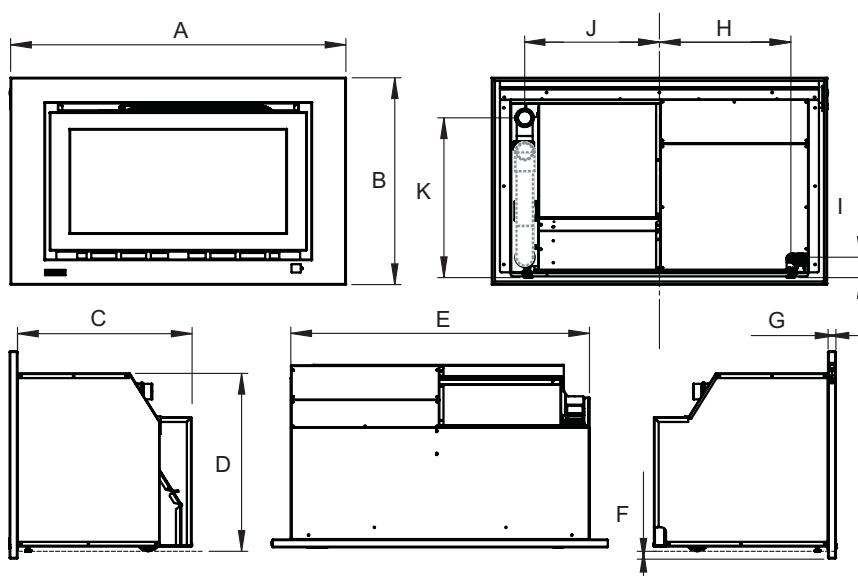

	<b>RHFE-950ETR</b>	<b>RHFE-1250ETR</b>
<b>A</b>	1070	1320
<b>B</b>	660	620
<b>C</b>	560	560
<b>D</b>	568	568
<b>E</b>	960	1255
<b>F</b>	25	25
<b>G</b>	25	8
<b>H</b>	420	570
<b>I</b>	65	65
<b>J</b>	430	580
<b>K</b>	500 ± 25	500 ± 25
<i>All dimension in mm</i>		

# HEATER LOCATION

When positioning the heater the main variables governing the location are Flueing and Warm Air Distribution.

This heater must not be installed where curtains or other combustible materials could come into contact with it. In some cases curtains may need restraining.

## ENCLOSURE REQUIREMENTS

These Rinnai units have a cool outer casing allowing it to be installed into existing Masonry fireplace or into a decorative fireplace constructed from combustible materials such as wood or plaster.



**For all installations, ONLY Rinnai ASP & ES Flue components MUST BE used. The Rinnai RHFE-950ETR & RHFE-1250ETR units MUST NOT be flued into 'natural draft' flue system or via a chimney.**

**Consult the Rinnai "Power Flued Flamefire Space Heater Co-axial Flue System Installation Manual" supplied with flue kits ASPDFK or ASPKIT03 for detailed flue installation instructions.**

A pair of wheels located at the rear the heater allows it to slide in and out of the enclosure for ease of commissioning and maintenance. As such the heater must be positioned on a flat and level surface that allows free movement.

In a masonry fireplace, use a slurry of sand and cement to level the base as required.

In a decorative fireplace, if the appliance is elevated from the ground, a base must be constructed using a board with supporting joists as shown. The joists used to support the appliance off the ground **MUST BE** capable of supporting a minimum of 105 kg.

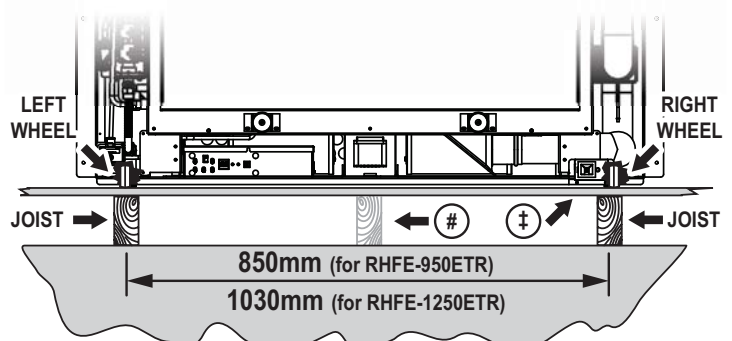

‡ MDF (Customwood) board Minimum 20mm

# Please Note: there is a third wheel in the centre for the RHFE-1250ETR

Enclosure Dimensions			
		RHFE-950ETR	RHFE-1250ETR
Ⓜ	Width	965 mm to 980 mm	1265 mm to 1280 mm
ⓗ	Height	570 mm to 580 mm	570 mm to 580 mm
ⓓ	Depth	570 mm (minimum)	

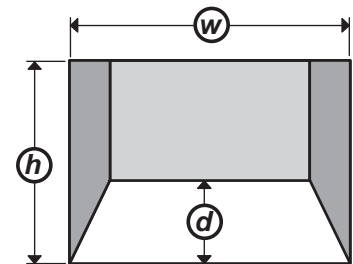

**The enclosure dimensions specified are critical to the successful installation of this appliance and must be strictly adhered to.**

## WALL PENETRATION REQUIREMENTS

Mark the location of the gas supply (consumer piping) and flue pipe penetrations from the centreline ① of the heater enclosure using the following dimensions:

RHFE-950ETR	RHFE-1250ETR
① Centreline of enclosure	① Centreline of enclosure
② 420 mm left of centreline	② 570 mm left of centreline
③ 65 mm from base of enclosure	③ 65 mm from base of enclosure
④ 430 mm right of centreline	④ 580 mm right of centreline
⑤ 500 mm from base of enclosure plus or minus 25mm	

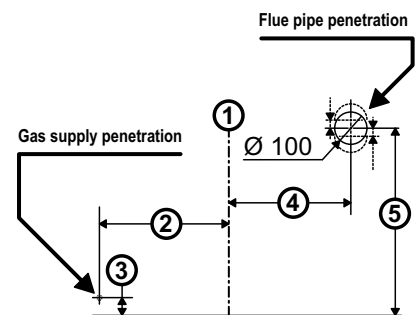

Consideration must be given to the position of any studs, noggins or other components of the wall structure.



**Ensure the penetration points are marked accurately as this is critical for successful appliance installation.**

The penetration for the flue pipe only needs to be made for 'Direct' flue installations, where the flue terminal is located directly to the rear of the appliance.

If no flue pipe penetration is required the markings are still useful for indicating the correct position of the flue transition within the enclosure for extended horizontal flue applications.

**GAS SUPPLY**

The gas supply terminates inside the heater and enters the appliance from the rear. To ensure correct positioning, terminate the gas supply so that it is 175 mm from the front of the enclosure opening.

Fit the supplied adapter and flexible hose to the gas supply prior to moving the heater into the enclosure.



Gas pipe sizing must consider the gas input to this appliance as well as all other gas appliances in the premises. The gas meter and regulator must be specified for the total gas rate. Suitable sizing chart such as the one in AS/NZS 5601 should be used.

**PURGING THE GAS SUPPLY:** All foreign materials such as filings must be purged from the gas supply, as they may cause the gas control valve to malfunction.

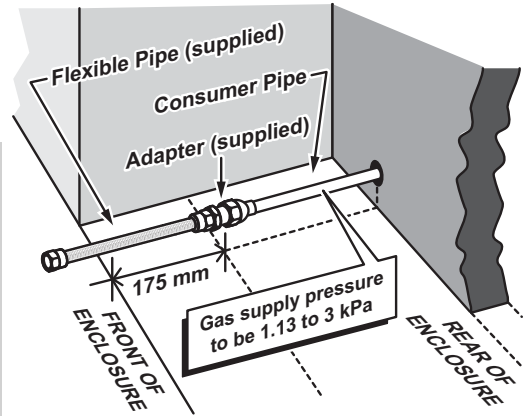

**ELECTRICAL SUPPLY**

This heater has a power cord with a three pin plug supplied. The power cord passes through the gap at the rear left of the appliance.

Rinnai recommend the heater be plugged into a 240V, 10A earthed power point. The power point must be a maximum of 1500 mm to the side of the heater (it must not be above the heater). Alternatively the appliance can be direct wired if the power supply is to be concealed.



Consult a qualified electrician if direct wiring is required as it must comply with the requirements of AS/NZS 5601 and AS/NZS 3000 and any other relevant local regulations.

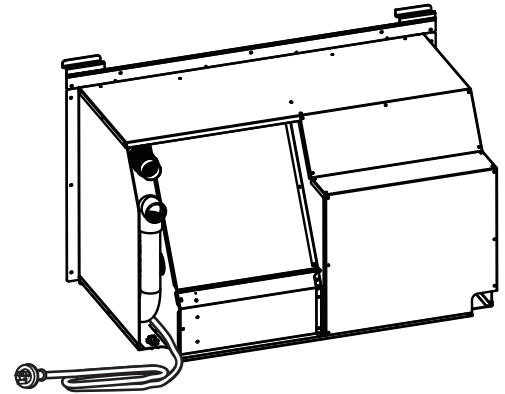

**MANTLE INSTALLATIONS**

A mantle is permitted providing the following clearances are met.

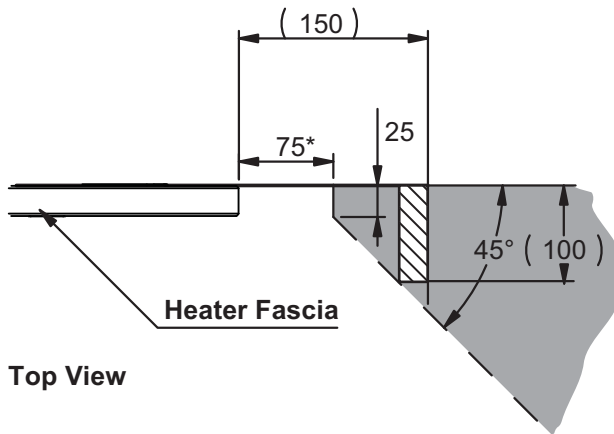

Top View

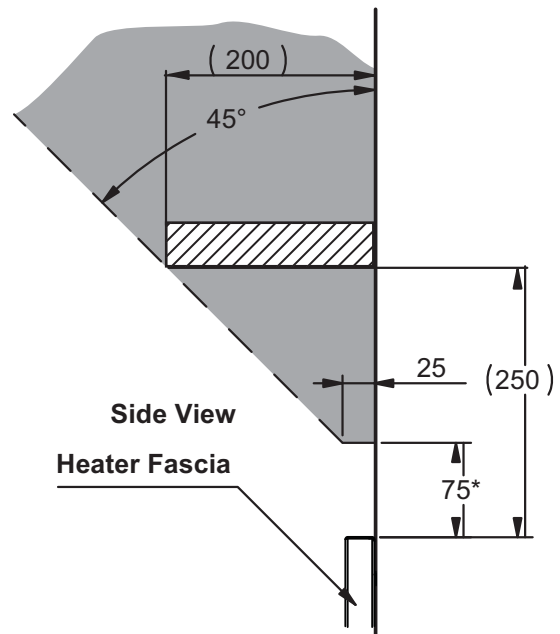

Side View

Mantles are allowed within the shaded areas



\* 75 mm is the minimum clearance required for access to the heater controls and to allow cleaning / servicing.

# FLUE INSTALLATION

## TYPES OF FLUE INSTALLATIONS



Consult the Rinnai “Power Flued Flamefire Space Heater Co-axial Flue System Installation Manual” supplied with flue kits ASPDFK or ASPKIT03 for detailed flue installation instructions. Use only Rinnai Flue components with this appliance.

Option	Components	Order Codes	
① <i>Direct</i>	‘Direct Flue’ Kit	ASPDFK	
② <i>Vertical Extension</i> <sup>A</sup>	‘On Wall’ Kit Co-axial Pipe 900mm* Roof Cowl	ASPKIT03 ESPIPE900 ESROOFCOWL	
② <i>Vertical Extension</i> <sup>B</sup>	‘On Wall’ Kit Co-axial Pipe 900mm* Bends (2 x 45°) Roof Cowl	ASPKIT03 ESPIPE900 ESBEND ESROOFCOWL	
③ <i>Vertical Extension</i> <sup>A</sup>	‘Direct Flue’ Kit Co-axial Pipe 900mm* Bends (2 x 45°) Condensate Trap Kit Roof Cowl	ASPDFK ESPIPE900 ESBEND ESCONDK ESROOFCOWL	
③ <i>Vertical Extension</i> <sup>B</sup>	‘Direct Flue’ Kit Co-axial Pipe 900mm* Bends (2 x 45°) Condensate Trap Kit Wall Terminal Kit	ASPDFK ESPIPE900 ESBEND ESCONDK ESWTKIT	
④ <i>Sideways Extension</i>	‘On Wall’ Kit Co-axial Pipe 900mm * Wall Terminal Kit	ASPKIT03 ESPIPE900 ESWTKIT	
⑤ <i>Down &amp; Out Extension</i>	‘On Wall’ Kit Co-axial Pipe 900mm* Bends (2 x 45°) Wall Terminal Kit	ASPKIT03 ESPIPE900 ESBEND ESWTKIT	
* Order number of lengths as required			



Flue is NOT to be terminated under the floor or in a roof space.

‘Down & Out’ and vertical ‘through roof’ flue installations are permitted ONLY when the flue terminal is located externally.



For horizontal installations there must be a continuous fall of at least 2° to the termination point to drain condensate.

All terminations exceeding a vertical height of 1.5 metres must incorporate a condensate trap.

‘Down & Out’ flue systems must have a continuous fall of at least 2° to the termination point to drain condensate. Flue terminal must be at least 300 mm above the ground in accordance with AS/NZS 5601 - Fig. 6.2.

## FLUE SYSTEM TRANSITION CASTING

The flue system transition casting provides a connection between the flue system and the heater’s flue spigot and air intake hose.

A minimum 5 mm clearance from combustible materials to the transition casting is required.

This clearance is provided automatically when the ‘stand off’ brackets ④ that are supplied are used.

Flue system transition casting components are: ① transition casting flue outlet, ② transition casting air inlet and ③ Wall plate.

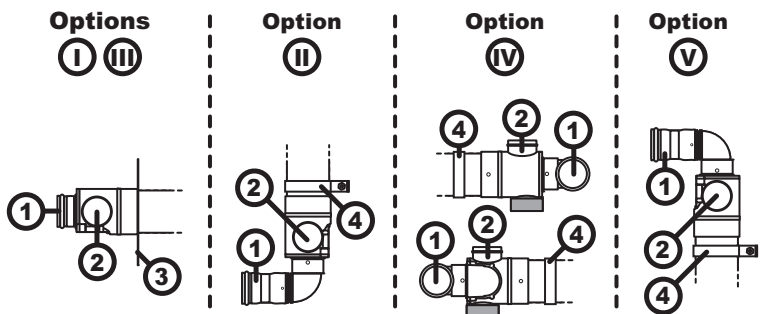

FLUE TERMINAL LOCATION



The flue terminal should be positioned away from flammable materials.  
 The RHFE-950ETR & RHFE-1250ETR flue terminal are 'Fan Assisted' with a maximum input of 34 MJ/h  
 Ensure that the location of the flue terminal can comply with the requirements of AS/NZS 5601 - Fig. 6.2 which is reproduced below.

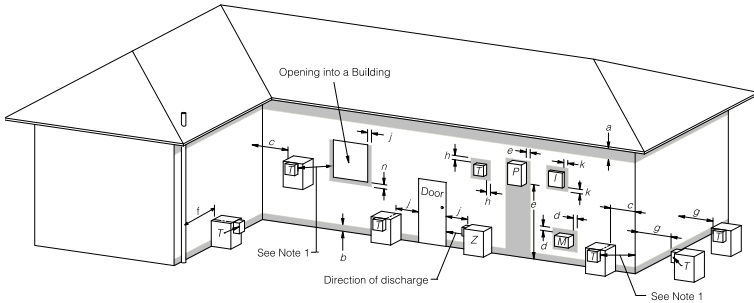

T = Flue terminal Z = Fan assisted flue appliance only M = Gas meter P = Electricity meter or fuse box I = Mechanical air inlet  
 Shading indicates prohibited areas for flue terminals

Ref.	Item	Min. clearances (mm)	
		Natural draft	Fan assisted
Below eaves, balconies and other projections:			
a	• Appliances up to 50 MJ/h input	300	200
	• Appliances over 50 MJ/h input	500	300
b	From the ground, above a balcony or other surface *	300	300
c	Front a return wall or external corner *	500	300
d	From a gas meter (M) (see 5.11.5.9 for vent terminal location of regulator) (see Table 6.6 for New Zealand requirements)	1000	1000
e	From an electricity meter or fuse box (P) †	500	500
f	From a drain pipe or soil pipe	150	75
g	Horizontally from any building structure* = or obstruction facing a terminal	500	500
h	From any other flue terminal, cowl, or combustion air intake †	500	300
Horizontally from an openable window, door, non-mechanical air inlet, or any other opening into a building with the exception of sub-floor ventilation:			
j	• Appliances up to 150 MJ/h input *	500	300
	• Appliances over 150 MJ/h input up to 200 MJ/h input *	1500	300
	• Appliances over 200 MJ/h input up to 250 MJ/h input *	1500	500
	• Appliances over 250 MJ/h input *	1500	1500
	• All fan-assisted flue appliances, in the direction of discharge	-	1500
k	From a mechanical air inlet, including a spa blower	1500	1000
Vertically below an openable window, non-mechanical air inlet, or any other opening into a building with the exception of sub-floor ventilation:			
n	• Space heaters up to 50 MJ/hr input	150	150
	• Other appliances up to 50 MJ/hr input	500	500
	• Appliances over 50 MJ/h input and up to 150 MJ/h input	1000	1000
	• Appliances over 150 MJ/h input	1500	1500

\* - unless appliance is certified for closer installation  
 † - Prohibited area below electricity meter or fuse box extends to ground level.

NOTES:

- Where dimensions c, j or k cannot be achieved an equivalent horizontal distance measured diagonally from the nearest discharge point of the terminal to the opening may be deemed by the Technical Regulator to comply.
- See Clause 6.9.4 for restrictions on a flue terminal under a covered area.
- See Figure J3 for clearances required from a flue terminal to an LP Gas cylinder. A flue terminal is considered to be a source of ignition.
- For appliances not addressed above acceptance should be obtained from the Technical Regulator.

FIGURE 6.2 (in-part) MINIMUM CLEARANCES REQUIRED FOR BALANCED FLUE TERMINALS, FAN-ASSISTED FLUE TERMINALS, ROOM-SEALED APPLIANCE TERMINALS AND OPENINGS OF OUTDOOR APPLIANCES

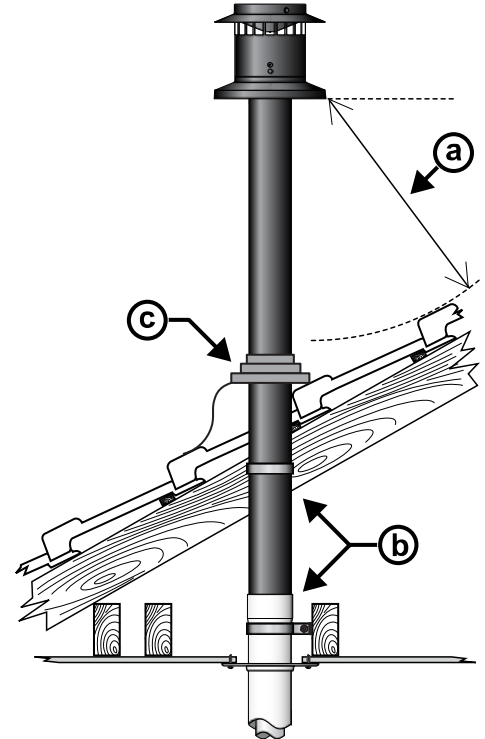

- (a) Minimum clearance 500 mm to nearest part of roof.
- (b) Minimum clearance 25mm to combustible materials.
- (c) Decktite or lead collar flashing.



AS/NZS 5601 was current at the time of printing but may have been superseded. It is the installer's responsibility to ensure that requirements of the current version of AS/NZS 5601 are met.

When installing a condensate trap kit (ESCONDK) the condensate MUST BE drained to the inbuilt condensation drain tray of the heater (refer to "CONNECTING THE FLUE SYSTEM" on page 24).

Consult the Rinnai "Power Flued Flamefire Space Heater Co-axial Flue System Installation Manual" supplied with flue kits ASPDFK or ASPKIT03 for further flue installation instructions.



The flue system must be fully assembled and secured in place before the heater is installed into the enclosure.

# HEATER INSTALLATION

## 1. UNPACKING THE APPLIANCE

The heater components are supplied in three main cartons. These cartons contain the heater body assembly, the fascia and the burner media for the contents of each carton refer to "CARTON CONTENTS / ITEM CHECKLIST" on page 4.

Check for damage and missing parts. If the heater is damaged or missing any parts, contact your supplier for advice. Before installing the appliance, check it is labelled for the correct gas type (see label on top rear of heater). Refer to local gas authority for confirmation of gas type if you are in doubt.

Remove the heater engine assembly from the engine carton and position in front of the enclosure opening.

## 2. CONNECTING THE FLUE SYSTEM

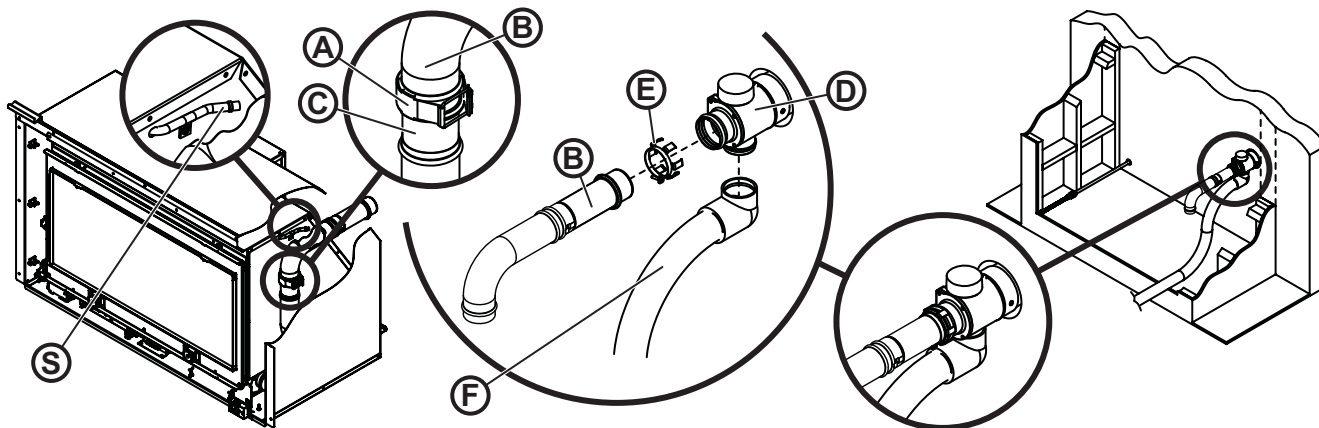

1. Un-clip pipe clamp (A) and remove the telescopic extension tube (B) from the exhaust pipe (C).
2. Secure the telescopic extension tube (B) to the flue system transition casting (D) with the exhaust pipe lock (E) and attach the air hose (F) to the flue system transition casting (D).



**When the condensate trap kit (ESCONDK) is installed, condensate products MUST BE drained to the heaters inbuilt condensation drain tray. With a continuous fall connect the drain hose (supplied with ESCONDK) from the condensate trap outlet pipe to the condensation drain tray inlet pipe (S).**



**The heater does not come supplied with flue components. These are purchased separately. ONLY the specified Rinnai flue components MUST be used with this appliance.**

**Connections between the heater and the flue system MUST BE made in accordance with the Rinnai "Power Flued Flamefire Space Heater Co-axial Flue System Installation Manual" supplied with flue kits ASPDFK or ASPKIT03.**

**Ensure the flue spigot of the heater is properly secured to the flue connection on the flue system transition casting using the clip and clamp provided.**

**If this joint is not secured properly products of combustion could disperse into the room being heated which may result in a dangerous condition.**

**Ensure the elbow of the air intake hose from the heater is properly secured to the air connection on the flue system transition casting using the cable tie provided and that the rubber seal is placed on the unused air intake connection of the transition piece.**

3. Carefully move the heater engine into the enclosure / cavity, guiding the consumer piping / flexible gas connection (G) and telescopic extension tube (B) into the access openings and through the appliance.

Ensure that the air hose (F) is also not in a position that it could be jammed behind or crushed by the engine.

4. Once the engine is home re-connect the flue exhaust (C) to the telescopic extension tube (B) and secure both together with pipe clamp (A).

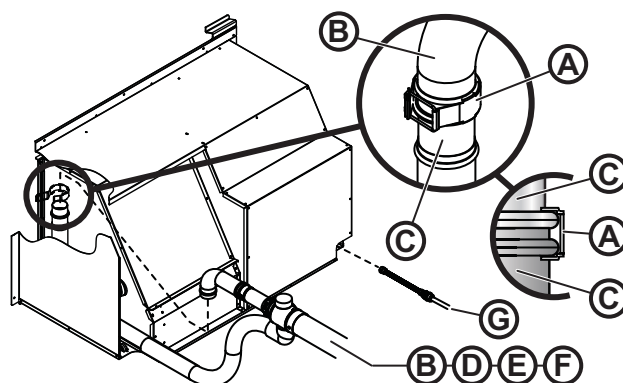



### 3. SECURING THE ENGINE

Once the heater is in position, secure in place with appropriate fixings through the 11 mounting points provided (H).

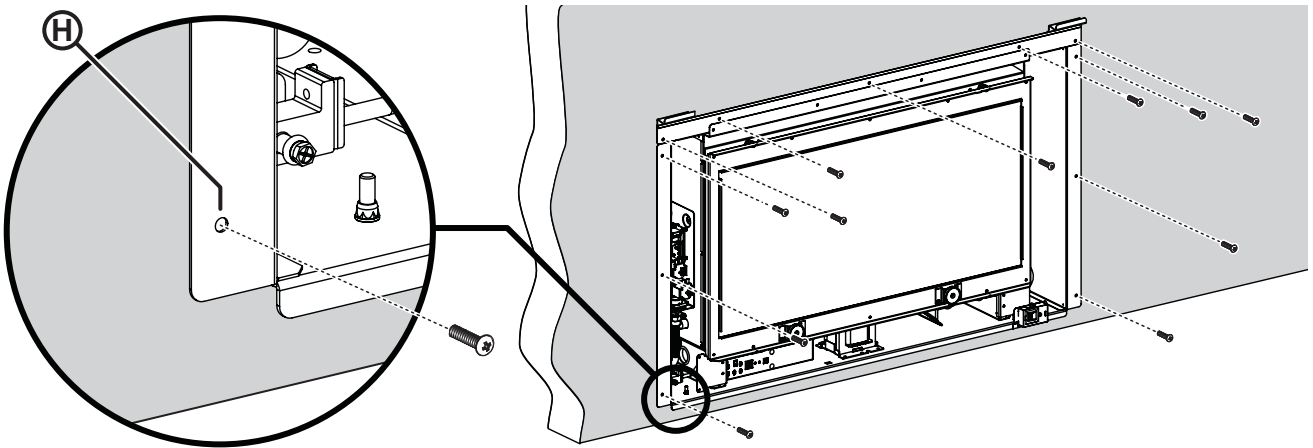

### 4. CONNECTING THE APPLIANCE TO THE GAS SUPPLY



**240 VOLTS, RISK OF ELECTRICAL SHOCK!**  
ISOLATE THE ELECTRICITY SUPPLY BEFORE CONTINUING.



Securely connect the consumer piping / flexible gas connection (G) to the appliances gas inlet point (I). Test all connections for gas leaks.

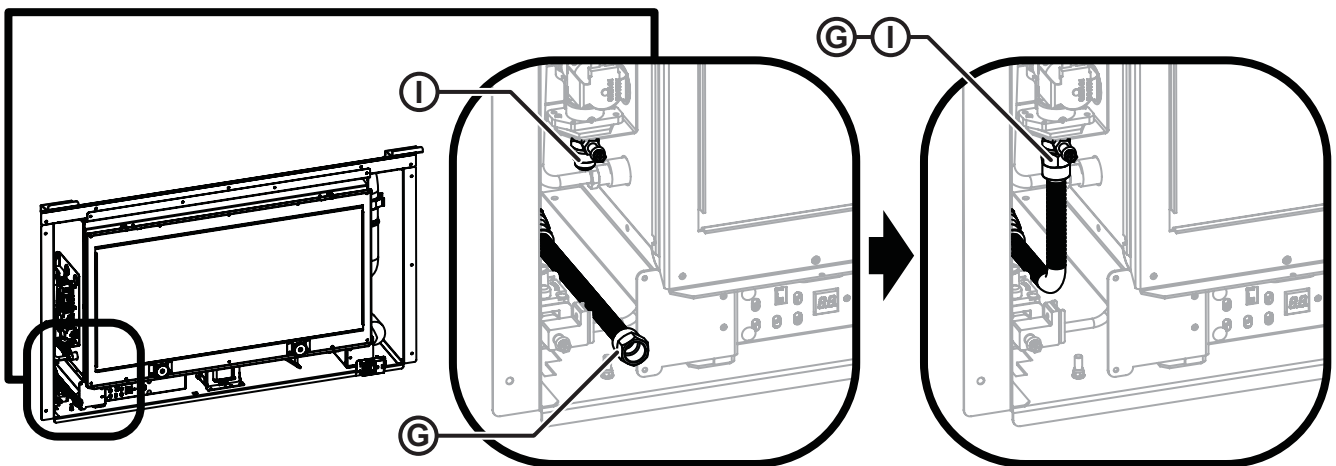

Use a soapy solution to test all gas connections. If a leak is present bubbles will form at the leak point. When finished remove any residue with a rag.

Prevent any soapy solution from coming in contact with the electrical components.

### 5. INSTALLING CERAMIC BURNER MEDIA

#### Removing Combustion Chamber Glass

Before the ceramic burner media can be installed the combustion chamber glass panel needs to be removed as follows:

1. Remove the four retaining screws (J) that secure the combustion chamber glass panel (K) to the heater engine.
2. Then Rotate and lift the combustion chamber glass (K) clear of the combustion chamber. Place both glass and screws in a safe location until required.

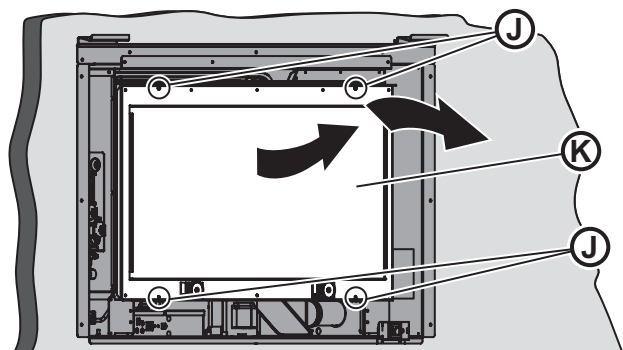



Before placing any burn media into the burner box, check to ensure that the ports of the main burner are clean and clear of any particles and all packaging material.

For clarity the drawings are displayed without showing the entire heater.

DO NOT remove the burner from heater engine to install the log set.

Use extreme care when handling the Log Set components, as they are made from a very fragile high temperature material and will damage if handled roughly, only remove the components from their packaging as required.

The log set (A.) or stones (B.) MUST BE installed in the positions as stated.



Check

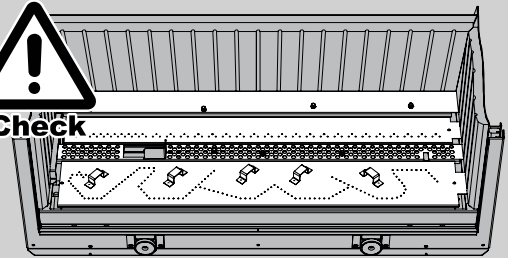

**A. Installation of Ceramic Log Set (RHFE-950ETR)**

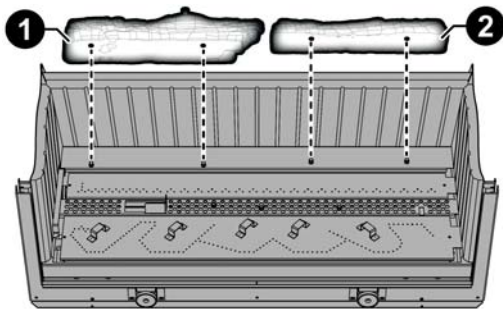

1. Logs 1 & 2 have a pair of pin holes in their bases, log 1 has an additional location pin on its top. Fit these logs to the back of the burner box as shown.

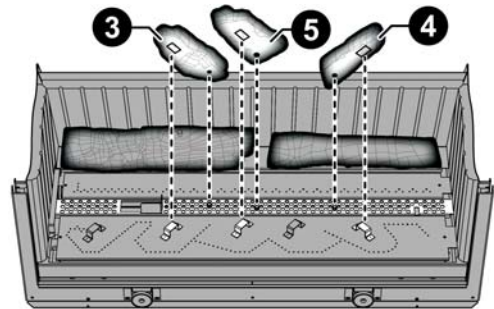

2. Logs 3, 4 & 5 each have both a pin hole and a slot in their base and are dimensioned as to only fit in a specific location. Fit these logs to the front of the burner box as shown.

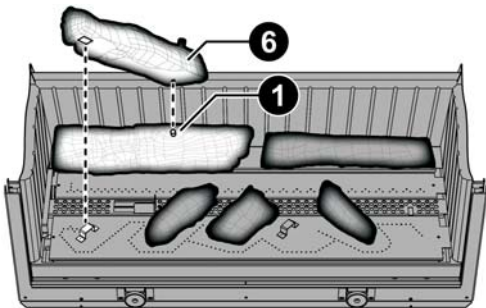

3. Log 6 has both a pin hole and a slot in its base and a location pin at one end on its top. Fit the log to front of the burner box and onto the pin of log 1 as shown.

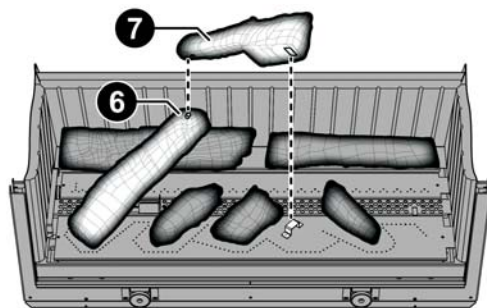

4. Log 7 has both a pin hole and a slot in its base and a location pin midway on its top. Fit the log to front of the burner box and onto the pin of log 6 as shown.

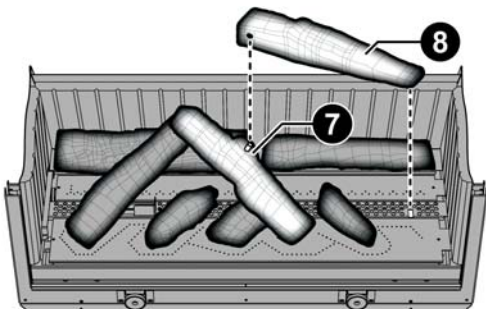

5. Log 8 only has a pin hole in one end of its base. Fit the log to slot in the middle of the burner box and onto the pin of log 7 as shown.



Check

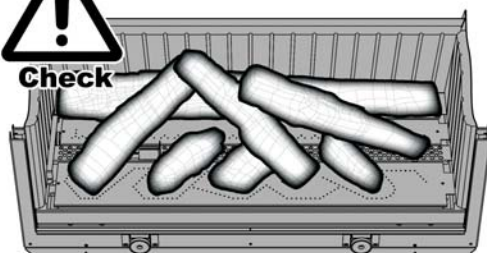

6. Confirm the correct location of all the logs before proceeding with the placement of the granular burner medium.

**A. Installation of Ceramic Log Set (RHFE-1250ETR)**

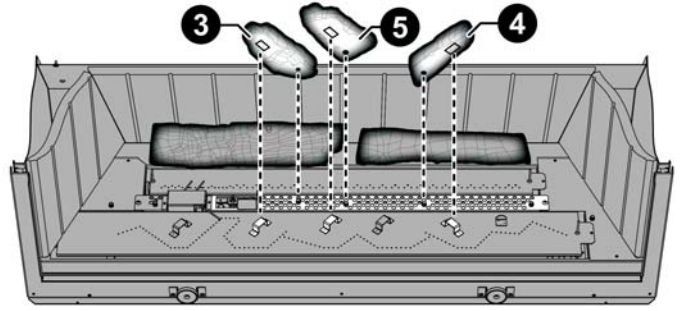
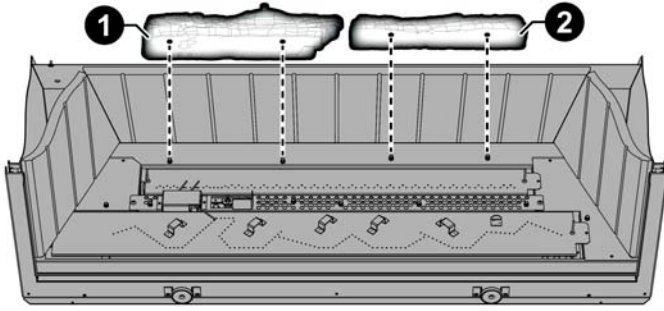

1. Logs **1** & **2** have a pair of pin holes in their bases, log **1** has an additional location pin on its top. Fit these logs to the back of the burner box as shown.

2. Logs **3**, **4** & **5** each have both a pin hole and a slot in their base and are dimensioned as to only fit in a specific location. Fit these logs to the front of the burner box as shown.

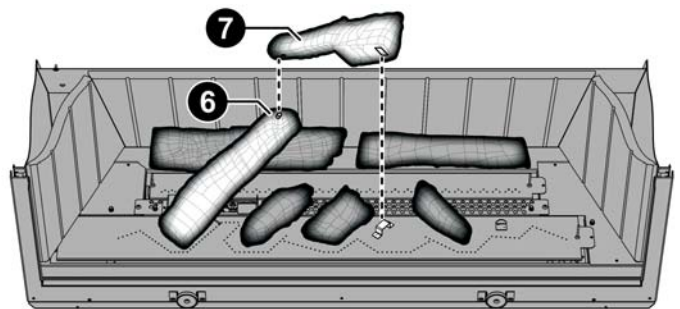
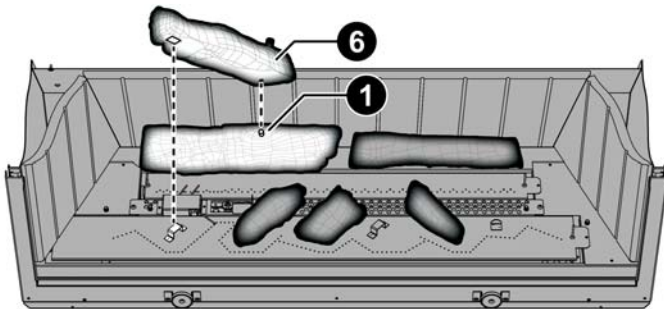

3. Log **6** has both a pin hole and a slot in its base and a location pin at one end on its top. Fit the log to front of the burner box and onto the pin of log **1** as shown.

4. Log **7** has both a pin hole and a slot in its base and a location pin midway on its top. Fit the log to front of the burner box and onto the pin of log **6** as shown.

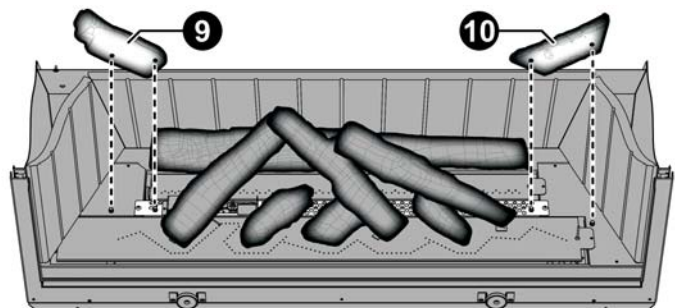
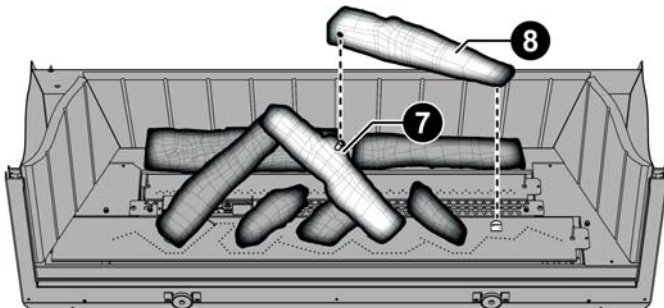

5. Log **8** only has a pin hole in one end of its base. Fit the log to slot in the middle of the burner box and onto the pin of log **7** as shown.

6. Logs **9** & **10** each have two pin holes in their base and are dimensioned as to only fit in a specific location. Fit these logs to the middle of the burner box as shown.

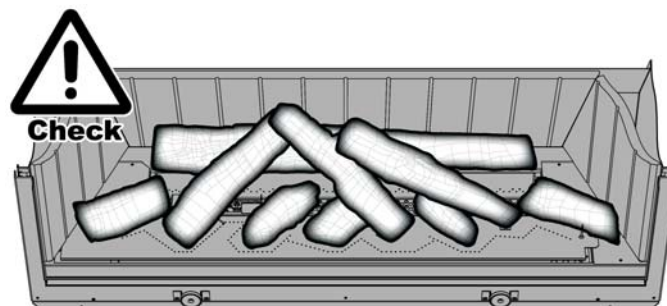

7. **⚠** Confirm the correct location of all the logs before proceeding with the placement of the granular burner medium.

**Installation of Granular Burner Media (Both Models)**

1. Ensure that all the logs are firmly seated in their correct positions and check that the ports of both burners are clean and clear of blockages from debris that may have been deposited during the log installation.
2. Carefully place the supplied granular burner media over and around the front and rear burner ports.

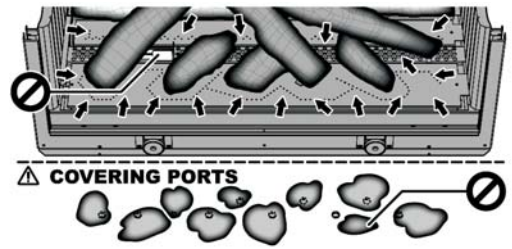

It is desirable that the gas jets are diffused by the granular burner media, as this will reduce any 'candling' effect of the flame, as well as enhance the flames look and the realistic log burning appearance of the heater. ⚠ DO NOT place granular material on top of the pilot or force any granular material into and or completely block any of the burner ports.

**B. Installation of Ceramic River Stones (Both Models)**

The stone set for the RHFE-950ETR consists of 30 stones of various size, colour, quantity and shape, of these there are 5 stones that have a central location slot ❶.

The stone set for the RHFE-1250ETR consists of 40 stones of various size, colour, quantity and shape, of these there are 5 stones that have a central location slot ❶.

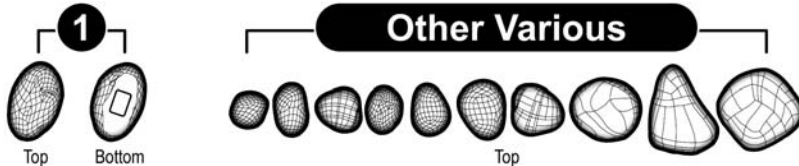

1. Place one of the slotted stones ❶ onto each of the five brackets located on the front burner, ensuring a random orientation of these stones will achieve the best visual appearance.
2. Place the remaining stone types evenly over the surface of both burners in a random manner, ensuring a random orientation of these stones will again achieve the best visual appearance.

The TOP VIEW image to the right may be used as an approximate guide to the stone placement.

3. Carefully place the supplied granular burner media in and around the stones. For the best flame effect carefully place the granular burner medium over and around the front and rear burner ports.

Note: The stone installation method for both heater models is essentially the same, with the RHFE-950ETR being shown.

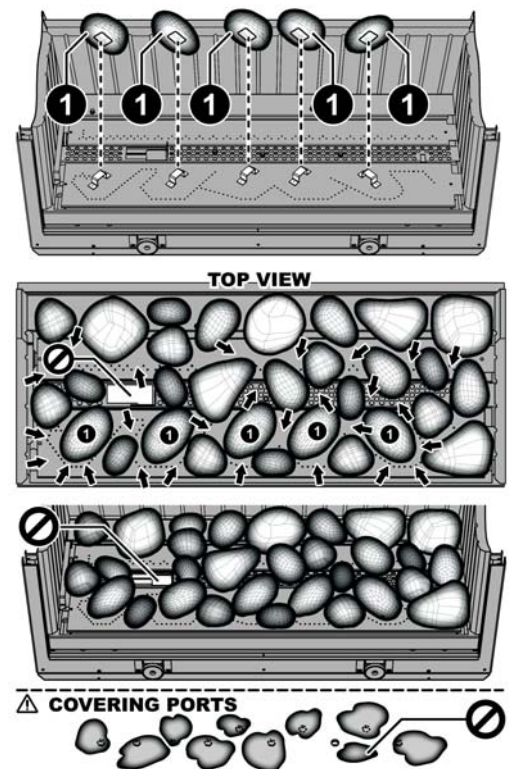

It is desirable that the gas jets are diffused by the granular burner media, as this will reduce any 'candling' effect of the flame as well as enhance the flames look. ⚠ DO NOT place granular material on top of the pilot or force any granular material into and or completely block any of the burner ports.

**Replacing Combustion Chamber Glass**

1. Tilt the Combustion Chamber Glass Ⓚ forward by about 10° and sit it onto the bottom supports of the Combustion Chamber frame and rotate back to vertical at the top.
2. Replace and **HAND TIGHTEN** the four retaining screws Ⓜ, then back each of the screws off by a ¼ of a turn to ensure the combustion chamber class retaining springs are engaged.

To test this gently pull the top of the glass frame forward and release, a correctly fitted the glass will spring firmly back into place and seal the combustion chamber.

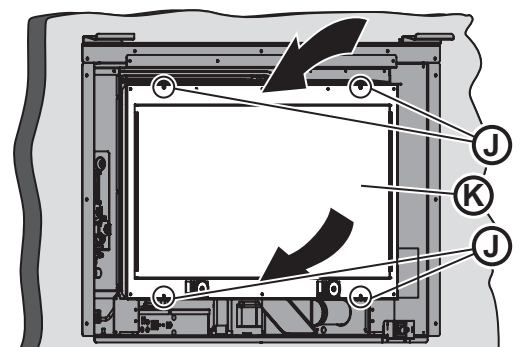

**6. COMMISSIONING**

**Extended Flue**

The gas pressures of the appliance are factory pre set for 'extended flue' installations (page 22 Options ②, ③, ④ and ⑤) and will normally not require adjustment and you may proceed to step 7).

**Direct Flue**

If the appliance is to be used with a 'direct' flue system (page 22 Option ①), then gas pressures will need to be adjusted in accordance with the commissioning instruction sheet ① located in a plastic pouch inside the appliance at the bottom right.

When commissioning is complete check for full and correct operation of the appliance, and return the commissioning instruction sheet to its plastic pouch, proceed to step 7.

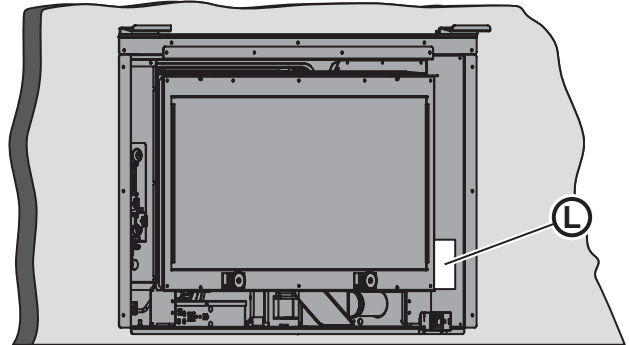

**7. INSTALLING THE OUTER FASCIA PANEL**

1. Remove but **DO NOT DISCARD** the two fascia retaining screws ④ shipped installed in the lower fascia mounting brackets ⑤ of the heater engine.

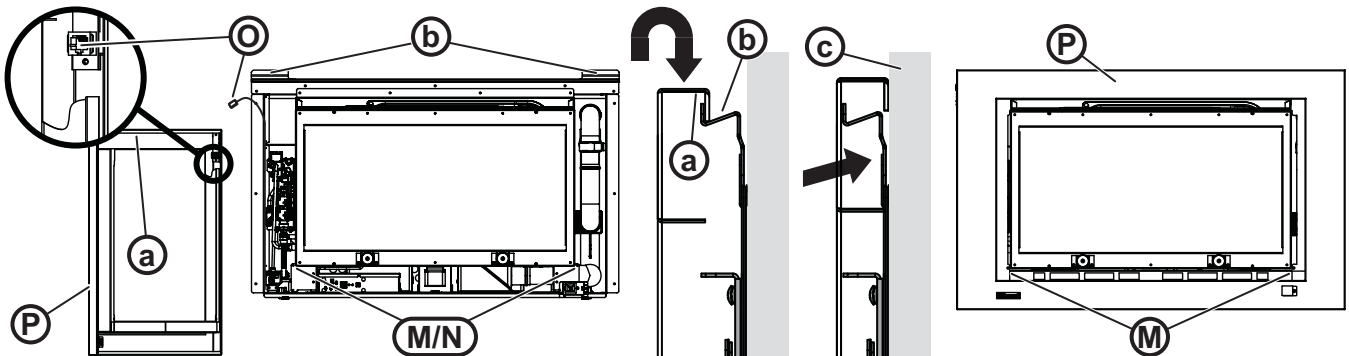

2. Position the fascia close to the heater engine and connect the RJ45 plug into the socket located on the inside top left of the fascia ①, (this connects the push button control panel via a communications cable to the heater engine's control box).
3. Mount the outer fascia ⑥ to the engine by hooking the top inside fold of the outer fascia ③ over the tabs on the top lip of the engine body ②, then push the outer fascia in towards the engine body until flush with the wall surface ⑧. Secure the fascia to the heater engine with two retaining screws ④.

**8. INSTALLING THE DRESS GUARD & INNER FASCIA PANEL**

1. Using slots ⑩ hang the mesh dress guard ⑪ onto the tabs ⑫ of the of combustion chamber glass frame.
2. Mount the inner fascia ⑬ to the engine by hooking the tabs of the inside top of the inner fascia ⑭ to the top lip of the combustion chamber frame ⑩.

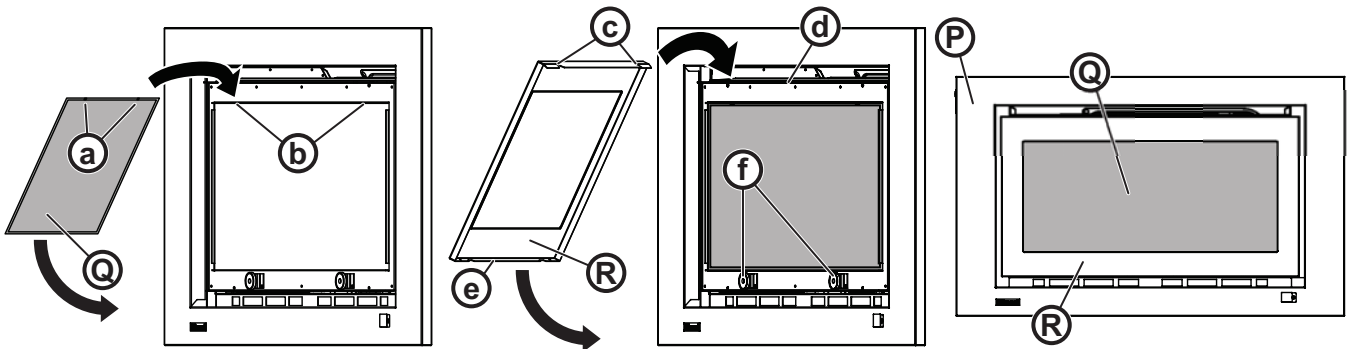

3. Rotate the bottom of the inner fascia ⑰ in towards the engine body allowing the magnets ⑮ to secure both the inner fascia and the dress guard to the heater engine.

**9. INSTALLATION AND COMMISSIONING CHECKLIST**

- Complete **BOTH** the “INSTALLATION RECORD” (Step 10.) and “FINAL CHECKLIST” (Step 11.) below.
- Instruct customer on functions and operation of the heater and remote control.
- Ensure the customer understands the content of this manual.



**Advise the customer that during the initial burning period of approximately 2 hours, some smoke and smell may be experienced. During this period the heater should be operated on ‘High’ and the space being heated should be well ventilated.**

- For protection of young children or the infirm a secondary guard is required.
- Ensure this Operation and Installation manual is left with the customer.



**Ensure the Customer understands that:  
No part of this appliance should be permanently removed.  
Paper or other material must not be burnt in this appliance.  
Young children and the infirm should be supervised at all times.**

**10. INSTALLATION RECORD**

**INSTALLERS / GAS FITTERS DETAILS**

Installers Name: \_\_\_\_\_

Company Name: \_\_\_\_\_

Company Address: \_\_\_\_\_

**COMPANY CONTACT DETAILS**

Telephone: \_\_\_\_\_

Mobile Phone: \_\_\_\_\_

**COMPLIANCE DETAILS**

Certificate of Compliance / Certification Number: \_\_\_\_\_

Authorised Persons - Licence Number: \_\_\_\_\_

Installers Signature: \_\_\_\_\_

Installation Date: \_\_\_\_\_

**APPLIANCE DETAILS**

Model Number: \_\_\_\_\_

Serial Number: \_\_\_\_\_

Installation Address: \_\_\_\_\_

\_\_\_\_\_

**11. FINAL CHECKLIST**

**(To be completed by certified Gas Installer)**

	NO	/	YES
1. Appliance positioned in a suitable location? (clearances, combustible clearances, mantels & surrounds, etc.).	<input type="checkbox"/>		<input type="checkbox"/>
2. Is a Rinnai approved flue system installed & tested in accordance with the instructions?	<input type="checkbox"/>		<input type="checkbox"/>
3. Gas pressure checked and set?	<input type="checkbox"/>		<input type="checkbox"/>
4. Has the burner media been installed as per instructions?	<input type="checkbox"/>		<input type="checkbox"/>
5. Appliance tested for correct operation and to ensure no gas leaks?	<input type="checkbox"/>		<input type="checkbox"/>
6. Customer instructed on operating procedure and safety requirements?	<input type="checkbox"/>		<input type="checkbox"/>
7. Is the end-user fully aware of operating procedure?	<input type="checkbox"/>		<input type="checkbox"/>

# WIRING DIAGRAM

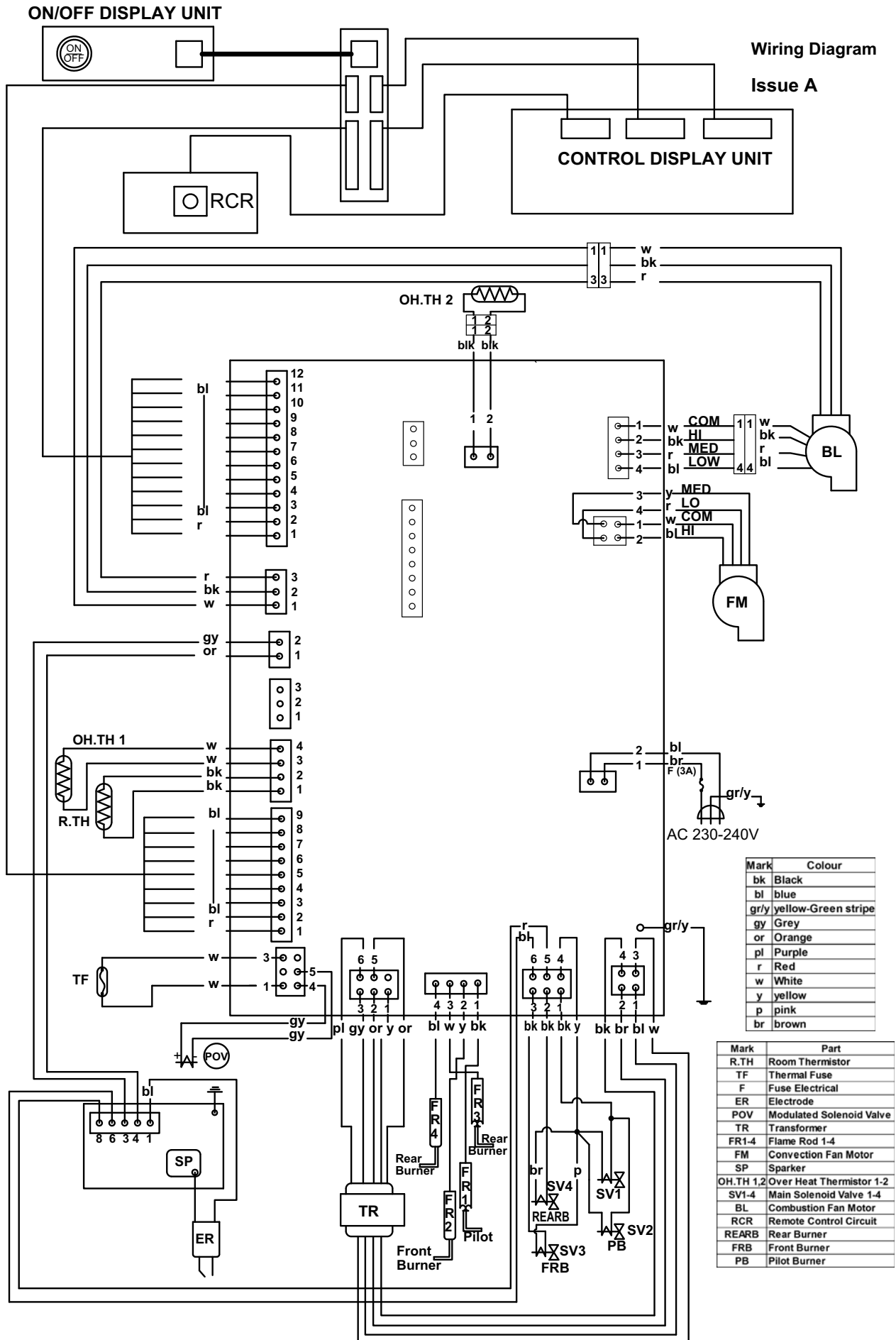

# Rinnai

**Rinnai Australia Pty. Ltd.** ABN 74 005 138 769

## Head Office

100 Atlantic Drive,  
Keysborough VIC 3173

P.O. Box 460  
Braeside, Victoria 3195

Rinnai has a Service and Spare Parts network with personnel who are fully trained and equipped to give the best service on your Rinnai appliance. If your appliance requires service, please call our National Help Line. Rinnai recommends that this appliance be serviced every 2 years.

## National Help Line:

Phone: 1300 555 545\* Fax: 1300 555 655\*

*\*Cost of a local call higher from mobile or public phones.*

E-mail: [enquiry@rinnai.com.au](mailto:enquiry@rinnai.com.au)

For further information visit: [www.rinnai.com.au](http://www.rinnai.com.au)

