

Rinnai

Operation & Installation Manual Rinnai 4 Star Gas Storage Water Heater

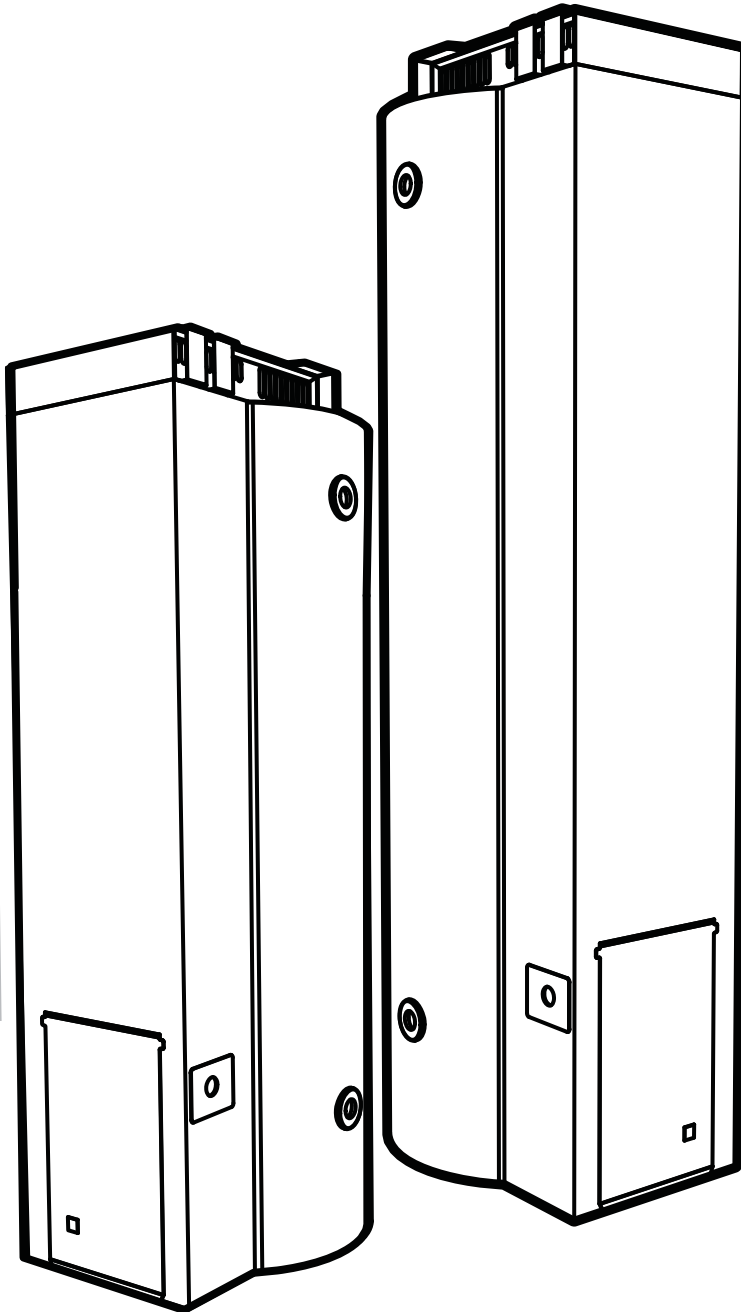

Models -
GHF4135N
GHF4135L
GHF4170N
GHF4170L

This appliance shall be installed in accordance with:

- Manufacturer's Installation Instructions
- Current AS/NZS 3500 & AS/NZS 5601
- Local Regulations and Municipal Building Codes including local OH&S requirements

This appliance must be installed, maintained and removed by an Authorised Person.

For continued safety of this appliance it must be installed operated and maintained in accordance with the manufacturers instructions.

This appliance is not suitable for use as a pool heater.



The Australian
Gas Association
All Rinnai gas products
are A.G.A. certified.

Certified
Product



WaterMark
This Appliance complies
with AS 3498
IAPMO Lic WM - 022424

This page is intentionally blank

TABLE OF CONTENTS - OPERATION MANUAL

REGULATORY INFORMATION.....	2
WARNING ABOUT HOT WATER	2
CUSTOMER OPERATING INSTRUCTIONS	3
Operating Instructions	3
Water Quality.....	3
How Long Will The Heater Run Each Day?	3
How Does My System Work?.....	4
By Owner - Six Monthly Service.....	4
By Authorised Personnel Only - Five Year Service.....	4
GENERAL INSTALLATION INSTRUCTIONS	5
Regulations	5
Outdoor Tank Installation	5
Location	5
Vertical Flue Terminal Clearances	5
Wall Brackets	6
Safe Tray	6
Water Supply Pressure	6
Pool Heating	6
Pressure & Temperature Relief Valve	6
Cold Water Connection	7
Insulation of Pipes	7
Temperature Protection	7
Inlet Connections.....	7
Appliance Dimensions	8
Appliance Specifications	9
Gas Connections	9
LPG Gas Installation Instructions	9
LIGHTING INSTRUCTIONS	10
Shutting Down The Water Heater	10
COMMISSIONING	11
Main Gas Pressure Regulator	11
Adjustment for LPG:	11
To set the LPG TPP:	11
TROUBLESHOOTING.....	12
What Should I Check Before Making A Service Call?.....	12
No Hot Water	12
Water Discharge from the PTR Valve	12
WARRANTY	13
Warranty (Domestic and Commercial use)	14
Replacement Guarantee (Domestic use only)	14
Table 1 - Water Characteristics.....	15
COMMISSIONING CHECK LIST.....	16

REGULATORY INFORMATION

Your Rinnai Gas Storage Hot Water Heater has been certified by the Australian Gas Association. The A.G.A. Certification Number is shown on the data plate.

This Appliance must be installed correctly by an authorised person. The installation of gas, water, and electricity must conform to local regulations.

The installation must also comply with the instructions supplied by Rinnai.

All dimensions referred to in these instructions are in millimetres, unless otherwise specified.

Please keep this instruction booklet in a safe place for future reference.

Notice to Victorian Consumers

This appliance must be installed by a person licensed with the Victorian Building Authority (VBA).

Only a licensed person will have insurance protecting their workmanship.

So make sure you use a licensed person to install this appliance and ask for your Compliance Certificate. For Further information contact the Victorian Building Authority on 1300 815 127.

WARNING ABOUT HOT WATER



Heated water can be dangerous, especially for young children and the infirm.

Water temperatures above 50°C can cause severe burns instantly and may even result in death.

Those most at risk are children, disabled, elderly and the infirm.

Hot water at 65°C (a very common hot water temperature in Australia) can severely burn a child in less than half a second. At 50°C it takes five minutes.

ALWAYS.....

Test the temperature of the water with your elbow before placing your child in the bath, also carefully feel water before bathing or showering yourself.

Supervise children whenever they are in the bathroom.

Make sure that the hot water tap is turned off tightly.

CONSIDER.....

Installing child proof tap covers or child resistant taps (both approaches will prevent a small hand being able to turn on the tap).

Setting your appliance at a maximum temperature of 50°C (Contact Rinnai Australia).

NEVER.....

Leave a toddler in the care of another child. They may not understand the need to have the water temperature set at a safe level.

CUSTOMER OPERATING INSTRUCTIONS

Gas Fitter:



This water heater should be checked on installation and the test point pressure set in accordance with that marked on Data Plate.

Adjust gas pressure as required to achieve specified gas test point pressure. If problems are encountered in this process, call Rinnai on 1300 555 545.

Failure to accurately set the pressure can result in damage to the water heater, and automatically cancels the Manufacturer's Warranty. This water heater is to be installed only by an Authorised Person.

User:

DO NOT place articles on or against this appliance.

DO NOT use store chemicals or flammable materials, or spray aerosols near this appliance.

DO NOT operate with panels or covers removed from the appliance.

Operating Instructions

This appliance is not intended for use by persons (including children) with reduced physical, sensory or mental capabilities, or lack of experience and knowledge, unless they have been given supervision or instruction concerning use of the appliance by a person responsible for their safety.

Children and animals should be supervised to ensure that they do not interfere with the appliance.



It is essential for the safe operation of this gas heater that clothing or any other flammable material should not be placed against or on top of the water heater. In addition, do not store flammable or corrosive materials, such as dry cleaning fluids, pool chemicals, etc., in close proximity to the heater.

The use of aerosol sprays in the vicinity of the heater should be avoided. The propellant gases used in these devices, e.g. fly-spray, hair-spray and laundry aids, can break down in the flames of the burner and produce corrosive agents.



If the water heater is left in an operating condition and unused for two weeks or more, a quantity of hydrogen (which is highly flammable) may accumulate in the top of the water cylinder. To dissipate this gas safely it is recommended that a hot tap be turned on for several minutes at a sink, basin or bath, but not a dishwasher, clothes washer or other appliance. During this procedure there must be no smoking, open flame or any other electrical appliance operating nearby. If hydrogen is discharged through the tap it will probably make an unusual sound as with air escaping.

Water Quality

Your water heater has been manufactured to suit water conditions of most Australian metropolitan supplies. Please note that harsh water supplies can have a detrimental effect on the water heater and its life expectancy. If you are unsure about your water quality you can obtain information from your local water supply authority.

The water heater is designed for use in areas where the Total Dissolved Solids (TDS) content of the water supply is less than 2500 mg/L. In areas where the TDS exceeds 600mg/L the magnesium alloy anode (supplied in the heater) may become over reactive. To alleviate this, the anode should be replaced with an aluminium alloy anode, available from your local Rinnai supplier.

Water can also be very corrosive, measured by the saturation index. If the water saturation index is greater than 0.40 an expansion control valve should be fitted and where the index is greater than 0.80 the water heater should be installed with a hard water anode. Please consult our Service Department for advice if required.

How Long Will The Heater Run Each Day?

The length of time that the heater will run each day will vary dependent upon the amount of hot water being used by the household.

CUSTOMER OPERATING INSTRUCTION



All water heaters have the ability to produce hot water in a surprisingly short time. To reduce the risk of scald injury, it is mandatory under the requirements of Australian Standards AS 3500 that an Australian Standards approved temperature control valve be fitted to the hot water supply pipe work. This valve should be checked at regular intervals to ensure its operation and settings remain correct.



Important there are no user serviceable components in the system. Only an authorised service representative is permitted to remove any covers or make setting adjustments.

Do not open or adjust any electrical covers or devices yourself.

How Does My System Work?

The water storage tank is used to store the heated water ready for household use. It has a high temperature vitreous enamel lining to provide long life, and a high density polyurethane insulation to ensure minimal heat loss. **Never turn the gas supply off during normal use.**

This water heater is designed such that there is little to do regarding system maintenance other than that detailed in this Owner's Manual.

Personally inspecting or servicing any part of the system is not recommended.

After each 5 years of operation you should contact the local service agent to replace all safety valves and anodes to ensure continued system life and operational safety. In locations where the water has a TDS greater than 600 ppm, this service is recommended each 3 years.

By Owner - Six Monthly Service

Operate the Pressure & Temperature Relief Valve for approximately 10 seconds by operating the easing lever on the valve to ensure water is relieved to waste through the relief drain pipe. Check to ensure the valve closes correctly.

By Authorised Personnel Only - Five Year Service

The five year service must be carried out by a licensed tradesperson. It is recommended that this service be carried out by your local Rinnai agent.

The service should include the following:

- Replace the Pressure and Temperature Relief Valve.
- Replace the anodes (in areas of harsh or adverse water conditions, a more frequent check of the anodes is recommended).
- Flush the water heater by doing the following:
 1. Turn off gas supply.
 2. Turn off the cold water supply to the water heater at the isolating valve.
 3. Gently operate the easing lever on the Pressure & Temperature Relief Valve to release the pressure in the water heater.
 4. Disconnect the cold water inlet union to the heater and attach a drain hose.
 5. Gently operate the Pressure and Temperature Relief Valve to let air into the heater and allow water to escape through the hose.
 6. Flush the heater until clear water appears then reconnect all fittings, fill the heater and restore the gas supply.

GENERAL INSTALLATION INSTRUCTIONS

Regulations

This appliance must be installed in accordance with:

- Current AS/NZS 3000, AS/NZS 3500 and AS/NZS 5601
- Rinnai Installation Instructions
- Local regulations and municipal building codes including local OH&S requirements

Installation, Service and Removal MUST BE by an Authorised Person only.

Outdoor Tank Installation

The water heater must be installed outdoors, with the minimum clearances as shown and must be installed on a permanently level, stable and clean draining surface suitable for this appliance. Refer to Figure 1 below.

We recommend a plinth be installed under the water heater where the water heater is subjected to wet conditions.

Minimum clearance around the windows and doors must be maintained - refer to AS/NZS 5601.

In areas where water pipes are prone to freezing, drain lines must be insulated, must not exceed 300 mm in length and are to discharge into a tundish through an air gap of between 75 mm and 150 mm.

Location

The water heater should be located as close as possible to the most frequently used hot water outlet. Ensure that the data label is clearly visible and that there is adequate access for servicing the unit.

All models are equipped with a sacrificial anode, accessible through the top cover. Allow 50% of the height of the water heater for clearance above to replace the anode.

Vertical Flue Terminal Clearances

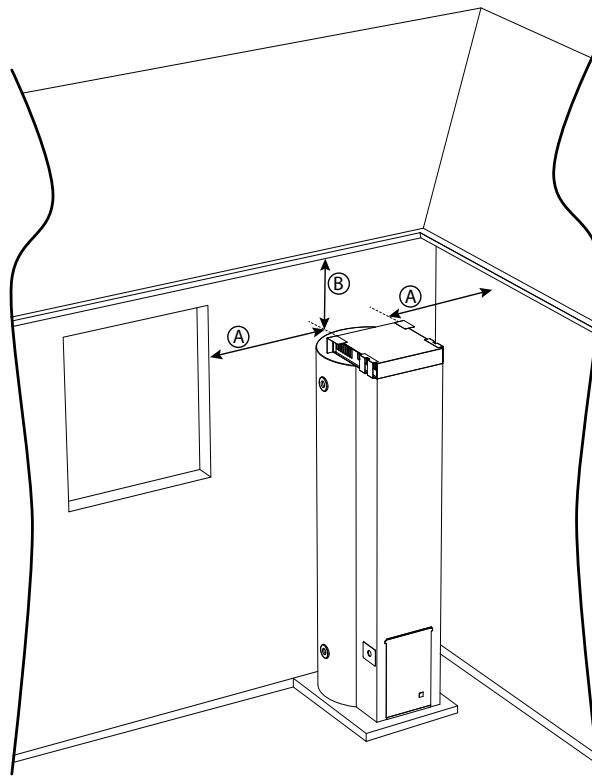

Figure 1 - Vertical Flue Terminal Clearances

Ⓐ	500 mm
Ⓑ	300 mm

Refer AS/NZS 5601 - Gas Installation Code for more information.

GENERAL INSTALLATION INSTRUCTIONS

Wall Brackets

For convenience, a wall mounting bracket and fixing screws are included with the Rinnai appliance. AS/NZS 5601.1 state that gas appliances shall be suitably supported or secured to a durable structure that is appropriate for the installation.

If this appliance is suitably supported on a durable structure then the installation of this bracket is at the discretion of the installer.

STEP 1.

Locate bracket at the top rear of the water heater and mark one of the three options for wall drilling, while in the same position mark the two self-tapping screw positions for the tank.

STEP 2.

Fix bracket to the top of the tank using the self-tapping screws provided.

STEP 3.

Fix bracket to the wall using a suitable fastener (installer to supply)

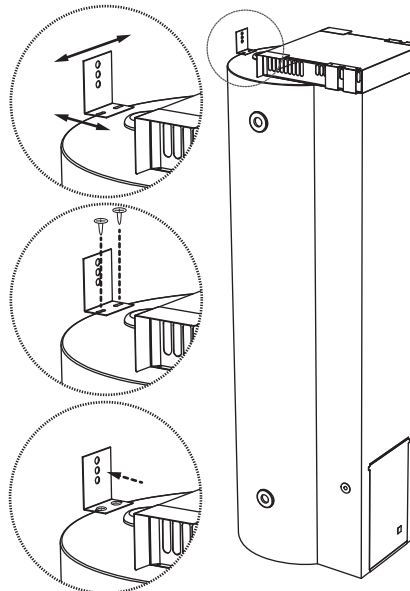

Safe Tray

If property damage could occur as a result of a leak or spillage from the water heater then a properly drained safe tray must be installed. The safe tray must be constructed and installed to the requirements of AS/NZS 3500.4 and any other local codes and regulatory authority requirements.

Water Supply Pressure

This water heater is designed for direct connection to water supply pressures of no greater than:

800 kPa - On All Models

Where the mains pressure can exceed or fluctuate beyond the pressure shown above a pressure limiting device (complying with AS 1357) must be fitted in the cold water inlet supply. This device must be installed after the isolating valve and set below the pressure shown above. During periods of lower demand water pressure may increase.

Pool Heating

This water heater must not be used for pool heating.

Pressure & Temperature Relief Valve

The Pressure & Temperature Relief Valve is supplied loose with the water heater. The valve rating is:

1000 kPa on All Models

- The PTR valve must be installed directly into the top socket marked "RELIEF VALVE". The drain line from this valve must run in a continuously downward direction in a frost-free ambient position with the discharge end left open to atmosphere permanently.
- The PTR Valve is not intended to enable connection of the water heater to supplementary energy sources such as solar panels or slow combustion stoves (refer AS/NZS 3500.4 for guidance on these types of installations).
- Open the PTR Valve for approximately 10 seconds by lifting the lever on the valve to ensure water is relieved to waste through the relief drain pipe. Lower lever gently and check that it closes correctly.

GENERAL INSTALLATION INSTRUCTIONS

- The PTR Valve must not be tampered with or removed. The water heater must not be operated unless this valve is fitted and in working order.
- The PTR Valve should be checked for adequate performance or replaced at intervals not exceeding 5 years, or less in areas where local regulations apply.



The PTR Valve and its drain outlet pipe must not be sealed or blocked. It is normal for the PTR valve to leak a small amount of water during heating cycles.

Danger:

Failure to operate the relief valve easing lever at least once every six (6) months may result in a problem with the water heater and in some cases the tank may fail.



A separate drain line must be run for this relief valve. It is not permitted to couple drain lines from relief valves into a single common drain line.

Cold Water Connection

An approved isolating valve, non return valve, line strainer (optional but recommended), and union must be fitted between the supply main and either of the RP $\frac{3}{4}$ /20 sockets marked "Inlet" at the bottom of the water heater. All fittings must be approved by the relevant Authority.



For S.A. and W.A.:

It is a state requirement that a pressure relief valve be fitted on the cold water supply line between the non return valve and the water heater. Refer to Inlet Connections refer Figure 2.

Hot Water Connection

The hot water pipe should be connected to either of the RP $\frac{3}{4}$ /20 sockets marked 'OUTLET' at the top of the unit. For the most economical operation of the water heater, it is recommended that all hot water lines are insulated.

Please check local regulations regarding the use of hot water supply pipework that are not made of copper.

Insulation of Pipes

All hot water pipes must be insulated with UV stabilised insulation.

Temperature Protection

Water heaters can produce very hot water. To reduce the risk of scald injury, it is mandatory under the requirements of Australian Standard AS/NZS 3500.4 that a suitably approved temperature control device be fitted to the hot water supply to outlets used primarily for personal hygiene. This valve should be checked at regular intervals to ensure its operation and settings remain correct.

Inlet Connections

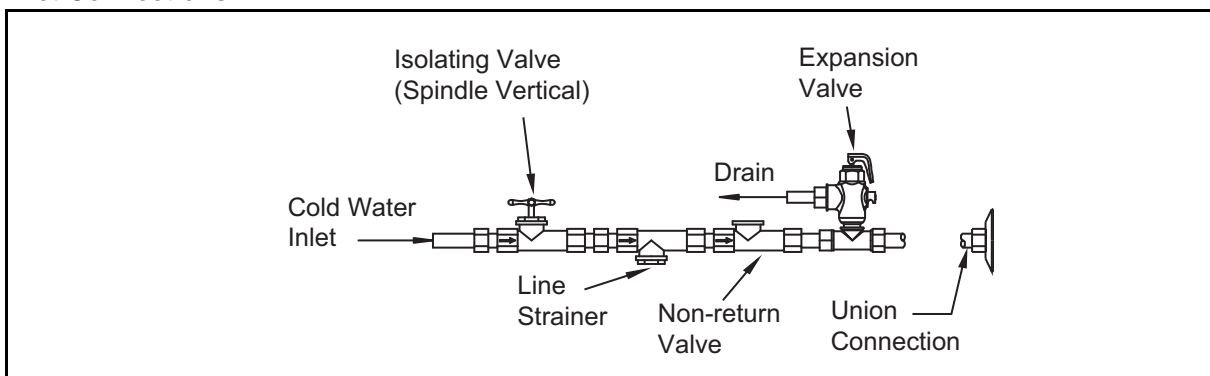

Figure 2 - Inlet Connections



A combined isolating valve/non-return valve/line strainer may be used. Expansion valve only required where local regulations demand or when the water saturation index is greater than 0.4.

GENERAL INSTALLATION INSTRUCTIONS

Appliance Dimensions

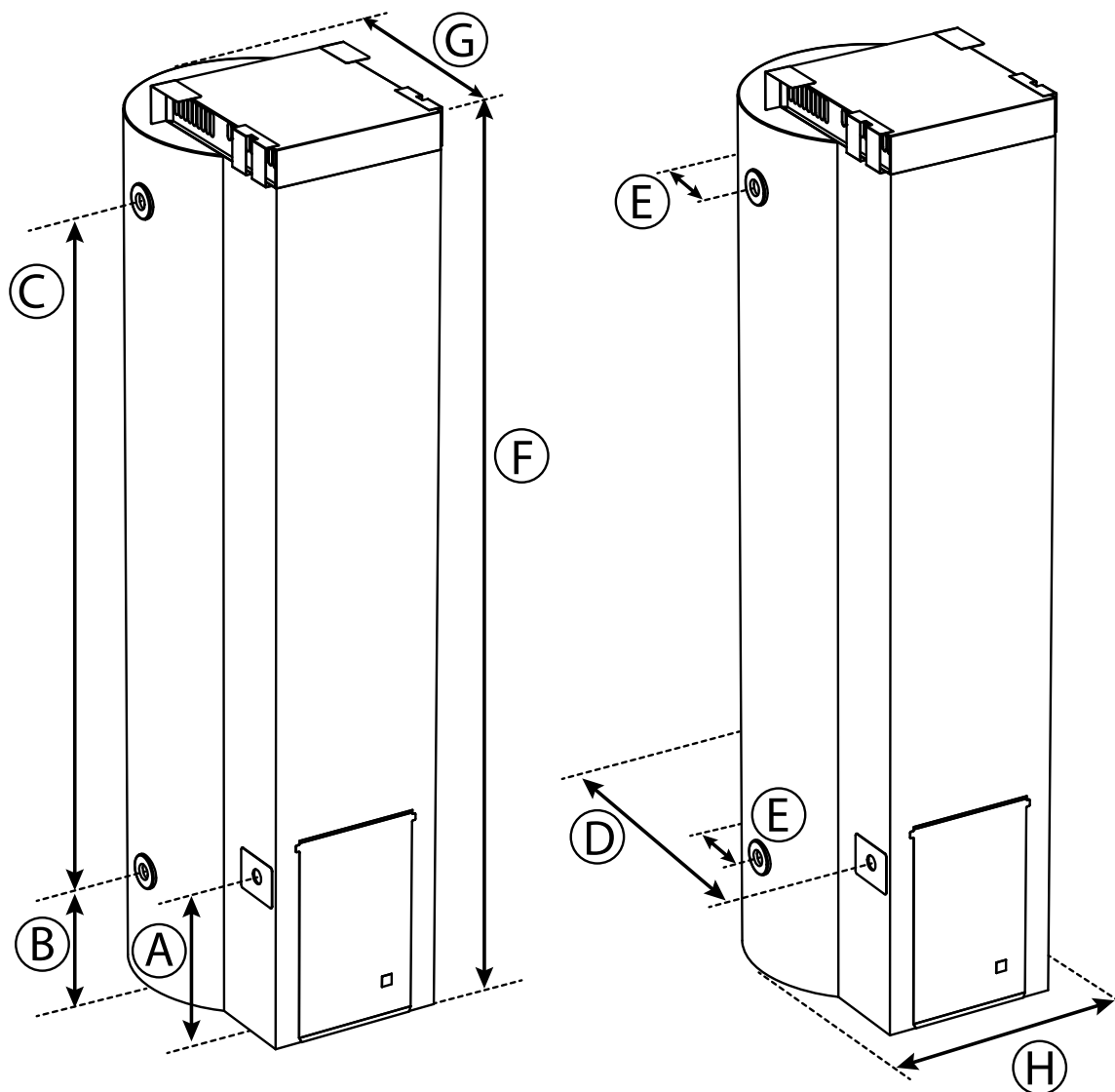

Figure 3 - Appliance Dimensions

Models		GHF4135N/L	GHF4170N/L
Storage Capacity (L)		135	170
Gas Pipe Height (mm)	Ⓐ	276	
Cold Water Inlet Height (mm)	Ⓑ	328	403
Hot Water / PTR Port Height (mm)	Ⓒ	988	1213
Gas Pipe Depth (mm)	Ⓓ	459	
Cold / Hot / PTR Port Depth (mm)	Ⓔ	210	
Overall Height (mm)	Ⓕ	1579	1915
Overall Depth (mm)	Ⓖ	508	
Overall Width (mm)	Ⓗ	420	
Weight (kgs) Empty		68	83
Weight (kgs) Full		203	253

GENERAL INSTALLATION INSTRUCTIONS

Appliance Specifications

Models: (Natural Gas) / (LPG)	GHF4135N/ GHF4135L	GHF4170N/ GHF4170L
Storage Capacity (L)	135	170
Star Rating	4 +	
Gas Type	Natural Gas / LPG	
Installation Type	External	
1st Hour Recovery @ 45°C rise (L/hr)	209	257
Hourly Gas Consumption - Natural Gas (MJ/hr)	17	20.5
Hourly Gas Consumption - LPG (MJ/hr)	17	19.5
Relief Valve Setting (kPa)	1000	
Maximum Water Supply (kPa) (Pressure without ECV)	800	
Maximum Water Supply (kPa) (Pressure with ECV)	680	
Water Connection (Hot and Cold)	Rp 3/4"	
Gas Connection to Gas Controller	Rp 1/2"	
Relief Valve Connection	Rp 1/2"	

Gas Connections

Refer to the Data Label for correct gas type. Gas piping should be connected through the side of the case (refer to Appliance Dimension Figure 3).

The gas control is fitted with a R3/4" thread for connection to the tank.

Gas pipe sizes should be in accordance with AS/NZS 5601. The pipe work must also be free of foreign matter before connection and purged before attempting to light the water heater.

LPG Gas Installation Instructions

LPG appliances use an external gas regulator as well as the SIT gas controller. The Maxitrol Gas Regulator is fitted with an RC $\frac{1}{2}$ "/15 socket. A union connection should be used. For LPG commissioning the SIT gas controls integrated pressure regulator is bypassed and the gas pressure adjusted via the Maxitrol Gas Regulator. The burner test point pressure (TPP) is measured via the 'SIT' Gas Control and adjusted via the 'Maxitrol' gas regulator.

LIGHTING INSTRUCTIONS



Before lighting the water heater, ensure there is no smell of gas near and around the base of the water heater and the main burner chamber.

IF YOU SMELL GAS:

- Do not light the water heater.
- Turn the gas control knob clockwise to the "•" (OFF) position
- Isolation the gas line to the water heater.
- Call Rinnai Service or a qualified service technician.

The water heater must be filled with water before lighting.

Instructions for lighting procedure are also on the inside of the access cover and shown below:



If the pilot flame or main burner does not light or is extinguished for any reason during the lighting process described below, you must turn the gas control knob to the "•" (OFF) position and wait 5 minutes.

1. Turn the knob fully clockwise to the "•" (OFF) position. Figure (a).
2. Wait five (5) minutes so any build-up of unburnt gas can escape. Figure (a).



Failure to wait 5 minutes may result in an explosive ignition and/or person injury.

3. Turn the knob to the ✨ pilot position. Figure (b).
4. Depress the knob fully (until disappears below housing) and after thirty (30) seconds, whilst keeping the knob depressed, repeatedly press the igniter button for up to forty (40) seconds until the ✨ pilot flame ignites. Figure (c).
5. Keep the knob depressed for twenty (20) seconds after the pilot flame lights. The pilot flame can be observed when on.
6. Release the knob and check if the pilot is still alight.
7. If pilot has failed to light turn gas control knob to "•" (Off). Wait Five (5) minutes for the escape of unburnt gas, then begin again at step 3.

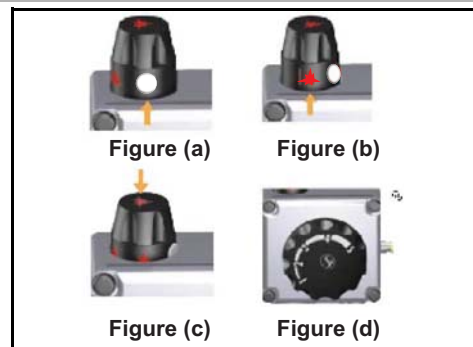

Failure to wait 5 minutes may result in an explosive ignition and/or person injury.

8. When the pilot flame remains alight with the knob released, turn the knob anticlockwise to the 🔥 flame setting. Turn the large dial anticlockwise to select the number setting. This will cause the main burner to light. A setting of "5" is recommended and this will give a water temperature between 60°C to 65°C.
9. Turn the knob to a lower number for lower water temperatures.
10. Replace the access panel and ensure that it is firmly in position before operating the appliance.
11. If the burner does not light at the selected setting, the water may already be at the selected temperature.

Shutting Down The Water Heater

1. Turn the knob to "•" (Off) position.
2. Turn water off at water isolating valve.
3. Turning Off Gas To The Appliance.
4. Turn the knob to "•" (Off) position.
5. Turn off the gas isolation valve.

To maintain safety and efficiency this heater should be serviced annually by an Authorised Service Agent.



Do not attempt to light if the pilot is out and the knob is in the "ON" position (one of the number settings). Follow steps above.

COMMISSIONING

Main Gas Pressure Regulator

Adjustment for Natural Gas:

The main burner pressure must be set at installation and should not need re-adjustment. The minimum Natural Gas Supply Pressure is 1.13 kPa. Test point pressure (TPP) on the gas control needs to be set at 1 kPa.

The pressure is best checked by connecting a water manometer or equivalent to the test point nipple on the gas control. The test point pressure must comply with the value on the Data Plate.

If adjustment is necessary, proceed as follows:

1. Remove the large dial ("A") from the top of the Gas Control.
2. Locate the regulator adjustment screw "PR ADJ".
3. Light the burner. Rotate adjustment screw clockwise to increase, or anti-clockwise to decrease pressure.

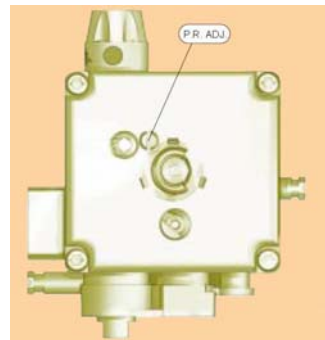
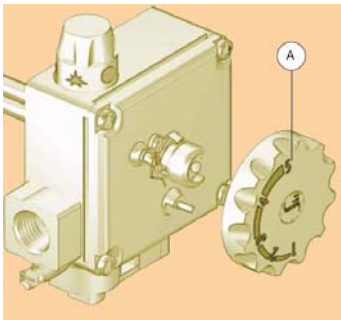

Figure 4 - Main Gas Pressure Regulator Adjustment

Adjustment for LPG:

The main burner pressure must be set at installation and should not need re-adjustment. The minimum LPG supply is 2.75 kPa. The burner TPP needs to be set at 2.70 kPa.

To set the LPG TPP:

1. Bypass the SIT Gas Control Integrated Pressure Regulator by removing knob A (refer to Figure 5) and adjusting the "NO P.R." screw clockwise, the screw will click once the integrated pressure regulator is bypassed (see Figure 6).

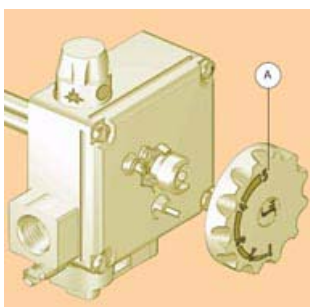

Figure 5 - Adjustment for LPG

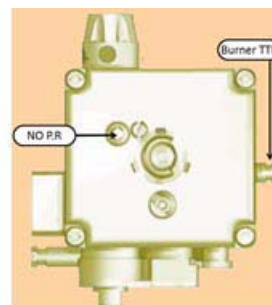

Figure 6 - Adjusting the "NO P.R." Screw

2. Connect a manometer to the Burner TPP position on the SIT Gas Control (see Figure 6).
3. Remove the Seal Cap on the Maxitrol Regulator and using a Philips head screw driver rotate the adjusting screw until the TPP described above is achieved.
4. Replace SIT Gas Control A and the Seal Cap on the regulator

Ignition System (Spark Gap) - Check the gap between the spark electrode and the pilot burner is 3-5 mm and adjust as necessary. Push the igniter button to test for a spark.



Pressure adjustments at gas cylinder regulator should be conducted as requested to ensure correct supply pressure to water heater as per AS/NZS 5601. Test the spark gap only where there is no build up of gas.

TROUBLESHOOTING

What Should I Check Before Making A Service Call?

If there is not enough hot water, it is recommended that the following points be considered before making a service call. If after checking the following points the problem has not been identified, please contact Rinnai on 1300 555 545.

No Hot Water

- Is the Pressure & Temperature Relief Valve discharging too much water?
- Do you have the correct size water heater for your requirements? Sizing details are available from your Rinnai supplier.
- Is one outlet (such as the shower) using more hot water than you think?
- Carefully review the family's hot water usage and if necessary check the shower flow rates with a bucket, measuring the amount of water used over that period of time. If it is not possible to adjust water usage patterns, an inexpensive flow control valve can easily be fitted to the shower outlet.
- Consider that during night time heating when the ambient temperature is cold, the time taken to heat the tank can take longer so you may find that the tank has not fully recovered from a period of heavy usage the previous evening.
- Consider that often the hot water usage of showers, washing machines and dishwashers can be under estimated. Review these appliances to determine if your daily usage is greater than the storage volume of your water heater. For example, if you have a 170 litre storage tank and you are using 300 litres of water it is possible that there will be certain times of the day where there is insufficient hot water. It is also advisable to inspect tap washers etc. for leakage and replace if necessary.
- Is there a leaking hot water pipe or dripping hot water tap? A small leak can waste a large quantity of hot water.
- Replace faulty tap washers and have your plumber rectify any leaking pipe work.

Water Discharge from the PTR Valve

Pressure & Temperature Relief Valve (PTR)

It is normal for the PTR to allow a small quantity of water to escape during the heating cycle. The amount of discharge will depend on hot water usage.

Continuous trickle (PTR)

This is most likely due to a build up of foreign matter. In this case try gently raising the easing lever on the Pressure & Temperature Relief Valve for a few seconds then release gently. This may dislodge a small particle of foreign matter and rectify the fault.

Steady flow (PTR) - more than 20L per day

This may be caused by excessive water supply pressure, a faulty Pressure & Temperature Relief Valve or a faulty thermostat. Turn off the gas supply and contact Rinnai.

WARRANTY

Applies only to Gas Storage Water Heaters where the model number commences with GHF, for example GHF4135N.

The benefits to the consumer given by this warranty are in addition to all other rights and remedies of the consumer under a law in relation to the goods or services to which the warranty relates.

Our goods come with guarantees that cannot be excluded under the Australian Consumer Law. You are entitled to a replacement or refund for a major failure and for compensation for any other reasonably foreseeable loss or damage. You are also entitled to have the goods repaired or replaced if the goods fail to be of acceptable quality and the failure does not amount to a major failure.

THIS HOT WATER SYSTEM COMES WITH A COMPREHENSIVE 1 YEAR PARTS AND LABOUR WARRANTY AND A GUARANTEE TO REPLACE YOUR HOT WATER UNIT IF THE INNER CYLINDER FAILS WITHIN EIGHT (8) YEARS under domestic use.

"Domestic Use" is defined as follows:

1. Water heaters installed to supply heated water to domestic dwellings.
2. Water heaters installed to supply heated water to commercial installations such as motel units, hotel rooms, caravans, mobile homes, nursing homes, retirement village complexes and other care institutions and like accommodation.

This water heater comes with a comprehensive one year parts and labour warranty under commercial use. Commercial use is defined as water heaters used in applications other than domestic use and include premises such as commercial and industrial buildings, cafes, caravan parks and sporting complexes, but not limited to these.

"Commercial Use" warranty applies to:

1. Water heater(s) supplying central shower blocks.
2. Water heater(s) supplying kitchens used for the bulk preparation of food.
3. Water heater(s) used in commercial or industrial heating processes.
4. Water heater(s) used in hydronic space heating installations.
5. Any application that uses Rinnai water heater(s) in conjunction with building flow and return systems.
6. Water heater(s) installed as component(s) of centralised bulk hot water system(s).

The terms of the Warranty and Replacement Guarantee are set out below.

This warranty applies to products which are manufactured on or after the date of publication of this warranty but before the next date of publication of this warranty.

No warranties except those implied and that by law cannot be excluded are given by Rinnai in respect of Goods supplied. Where it is lawful to do so, the liability of Rinnai for a breach of a condition or warranty is limited to the repair or replacement of the Goods, the supply of equivalent Goods, the payment of the cost of repairing or replacing the Goods or acquiring equivalent Goods as determined by Rinnai.

Rinnai is responsible for reasonable costs associated with legitimate warranty claims, including call-out of an authorised Rinnai service provider to inspect the faulty product. Rinnai is not responsible for:

- a. costs for tradespeople that are not authorised Rinnai service providers; or
- b. any costs, including call-out costs for an authorised Rinnai service provider, associated with a product which is determined upon inspection not to be covered by this warranty.

The consumer will be reimbursed by Rinnai for any reasonable costs associated with making legitimate warranty claims against Rinnai which are not otherwise specified above.

Enquiries relating to Warranty claims for Rinnai products or services must be made by contacting Rinnai Australia. Contact details are on the back of this document.

WARRANTY

Warranty (Domestic and Commercial use)

1. Your hot water system and its components are covered by a 1 year warranty against defective factory parts or workmanship from the date your hot water unit is installed. If the date of installation is unknown, the warranty commences 1 month after the date of manufacture (which can be found on the data plate on the hot water unit).
2. This warranty is for normal use of the hot water system and covers the repair and/or replacement of any failed component in the hot water unit or where necessary, the hot water unit itself. Under this warranty Rinnai will repair or replace the component or hot water unit free of charge.
3. The warranty only applies to defects in the hot water unit which have arisen solely due to faulty materials or workmanship.

Replacement Guarantee (Domestic use only)

4. If an inner cylinder fails on a Rinnai Gas storage hot water unit, within a further 7 years after the end of the 1st year warranty period, Rinnai will provide a free replacement hot water unit at the nearest approved Rinnai agent or Rinnai office to the owner's home. Under this replacement guarantee, the transport, installation and labour costs of delivering the replacement hot water unit and removing and replacing the existing hot water unit with the replacement hot water unit will be the responsibility of the owner of the existing hot water unit.

Scope of Warranty and Guarantee

5. The warranty and replacement guarantee do not apply to any defects or damage not due to faulty factory parts or workmanship, installation /system selection, including but not limited to defects or damage caused by or resulting from:
 - a. Accidental damage, abuse, misuse, maltreatment, abnormal stress or strain, harsh or adverse water conditions, contamination or corrosion from particles in the water supply, excessive water pressure, over temperature or neglect of any kind to the hot water unit or its components.
 - b. Alteration or repair of the hot water unit other than by an approved Rinnai agent or a Technician of a gas or electricity utility approved by Rinnai.
 - c. Attachment of any parts or accessories other than those manufactured or approved by Rinnai.
 - d. Faulty or improper installation of the hot water unit, including installation otherwise than in accordance with the instructions contained in the owner's manuals supplied by Rinnai.
 - e. Where cold water temperature and pressure relief valve, expansion valve, check valve and strainer is not fitted in areas where mains pressure is likely to exceed 1200 kPa.
 - f. The warranty only applies to the hot water unit or components in the hot water unit and does not cover any plumbing or associated parts, including but not limited to, pressure limiting valves, stop cocks, non return valves, electrical switches, pumps or fuses, supplied by any person installing the hot water unit.
 - g. Where a hot water unit or a component in a hot water unit is replaced by Rinnai, the balance of any original warranty or replacement guarantee period will remain effective. The replacement part or hot water unit does not carry any additional warranty or replacement guarantee.
 - h. Where the warranty applies but the hot water unit is installed or located in a position that does not comply with the Rinnai installation instructions or any relevant statutory requirements, the owner of the hot water system will be responsible for the costs of:
 - a. the dismantling or removal of cupboards, doors, walls of special equipment and
 - b. any labour required to gain access to and to bring the system / unit to a position that complies with the installation instructions or relevant statutory requirements.
6. Any claim under the warranty or replacement guarantee must include full details of the defect and/ or damage to the hot water unit or components in the hot water unit. All claims must be made within one month of the detection of the defect.
7. This warranty applies to water heaters connected to a water supply where the water chemistry and impurity levels do not exceed the limits specified in Table 1 below. The water supply from water utilities is deemed to comply with these requirements.

WARRANTY

8. This warranty does not apply to water heaters connected to water supplies if the water chemistry and impurity levels exceed the limits specified in Table 1 below. Examples of water supplies where chemistry and impurity levels may exceed the limits specified in Table 1 include but are not limited to private bores, private dams and water from water utilities where the chemistry is deliberately altered by parties other than the water utility before supplying the water heater. This warranty does not apply to damage caused by sludge and/or sediment in the water supply from water utilities where the chemistry is deliberately altered by parties other than the water utility before supplying the water heater.
9. This warranty does not apply to damage caused by sludge and/or sediment in the water supply.

Table 1 - Water Characteristics

For TDS levels up to and including 600mg/litre the Rinnai magnesium based anode is to be used. This is the anode fitted during manufacture of the cylinder. For TDS levels greater than 600mg/litre and not exceeding 2500 mg/litre the Rinnai aluminium based anode is to be used. This anode can be fitted by Rinnai or an authorised person. This warranty does not apply if the TDS exceeds 2500 mg/litre.

Table 1 - Water Characteristics					
Total Dissolved Solids (TDS)	Hardness (as CaCO ₃)	Saturation Index	pH	Dissolved CO ₂	Chlorides
2500 *	200	+0.4 to -1.0 @ 65°C	5.5 to 9.5	Not Applicable	Not Applicable

COMMISSIONING CHECK LIST

FINAL CHECKLIST

(To be completed by Certified Gas Installer)

- | | Yes | / | No |
|---|--------------------------|---|--------------------------|
| 1. Is the appliance positioned in a suitable location (clearances, combustible clearances windows and surrounds etc)? | <input type="checkbox"/> | | <input type="checkbox"/> |
| 2. Gas pressure checked and set? | <input type="checkbox"/> | | <input type="checkbox"/> |
| 3. Appliance tested for correct operation and to ensure no gas leaks? | <input type="checkbox"/> | | <input type="checkbox"/> |
| 4. Is the end-user fully aware of operating procedure? | <input type="checkbox"/> | | <input type="checkbox"/> |
| 5. Customer instructed on operating procedure and safety requirements? | <input type="checkbox"/> | | <input type="checkbox"/> |
| 6. Gas Supply pipe is purged of foreign matter before connection? | <input type="checkbox"/> | | <input type="checkbox"/> |

Installation Date:	
Installer's Name:	
Licence Number:	

This page is intentionally blank

Rinnai

Rinnai Australia Pty. Ltd. ABN 74 005 138 769

Head Office

100 Atlantic Drive,
Keysborough, Victoria 3173
P.O. Box 460
Braeside, Victoria 3195
Tel: (03) 9271 6625
Fax: (03) 9271 6622

Rinnai has a Service and Spare Parts network with personnel who are fully trained and equipped to give the best service on your Rinnai appliance. If your appliance requires service, please call our National Help Line. Rinnai recommends that this appliance be serviced annually.

Internet: www.rinnai.com.au E-mail: enquiry@rinnai.com.au

National Help Line

Tel: 1300 555 545* Fax: 1300 555 655*

**Cost of a local call higher from mobile or public phones.*