

INSTALLATION METHOD

- 1 Prepare opening in brickwork. Brick opening – Height 1020~1050mm, Width 495~530mm, minimum depth for Recessed 230mm, minimum depth for Semi-Recessed 140mm.
(If the depth is less than 140mm the box is to be installed with the semi-recessed frame RBOX02F).
The Rinnai Recessed box can either be fitted as the brickwork is being laid using the fold out brick ties to secure the box, **or** in an existing installation, cut an opening in the brickwork and fix the box by drilling holes in the sides and fix in position with suitable flush headed masonry anchors.
- 2 Semi-Recessed installation using (RBOX02F). Assemble the frame components with screws supplied, utilising the pre-drilled holes located in each corner of the frame components. Slide the assembled frame onto the recess box from the rear and secure to the outer frame flange with screws supplied, utilising the pre-drilled holes 2 of each are located on each side.
- 3 The gas, cold water inlet and hot water outlet pipes can be brought through the pipe entry holes in the bottom panel of the box.
- 4 **IMPORTANT – The Rinnai water heater serial number and model number on the data plate located on the left hand side of the appliance, MUST be copied to the sticker on the inside of the access panel.** You will need to know the serial number for any warranty or service work.
- 5 Secure the bracket with the 5mm stud inside the top of the recess box. Facing the stud to the front of the recess box.
- 6 Each recess box is supplied with a right-angle bracket that has 3 small holes on the horizontal tab and a key-way on the vertical tab. This bracket is to attach the appliance to the 5mm stud in the top of the recess box. Remove the three screws located on the top of the water heater and use these to fix the bracket to the top of the water heater.
- 7 Hang the water heater on the top bracket over the stud in the top of the recess box and secure with a suitable fastener.
- 8 Ensure the lower bracket is located on the 5mm stud on the back panel of the recess box and secure with a suitable fastener.
- 9 When fitting the front access panel use a screw driver to bend out the tab retaining slots to 90° as shown in Fig. 1.
- 10 An approved weatherproof electrical GPO can be fitted either inside the recess box, or can be fitted adjacent to with the power lead brought through the gap at the bottom of the access cover.
- 11 Follow the Testing and Commissioning Procedure contained in the General Installation Instructions situated in the pouch behind the front panel of the water heater unit.
- 12 Seal all gaps inside the recess box with Silicon Sealant to prevent water from entering the wall cavity.
- 13 Tighten nuts to secure the appliance.
- 14 Ensure the warning sticker on the front panel is visible when the appliance is installed.

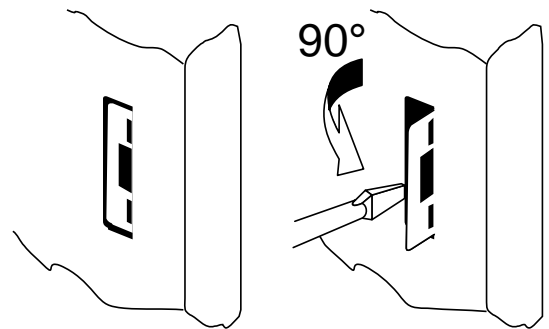
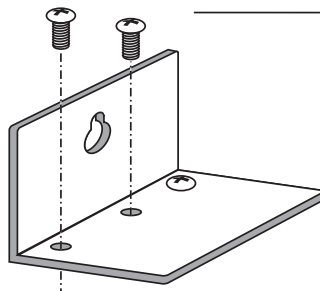
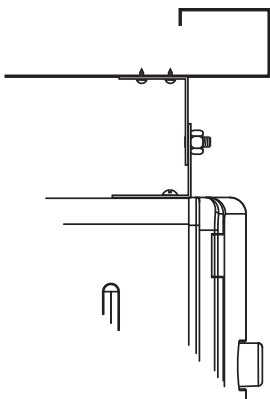
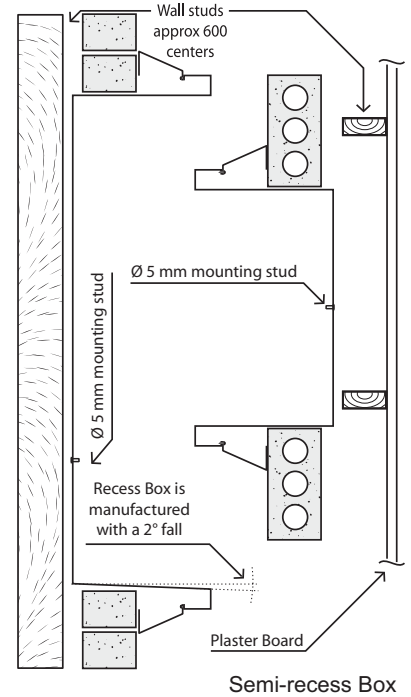
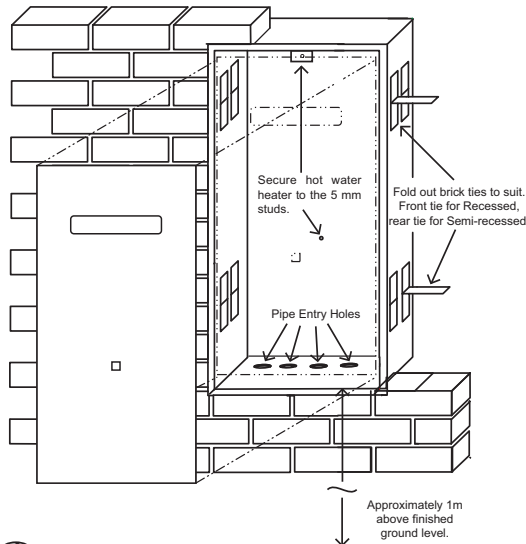
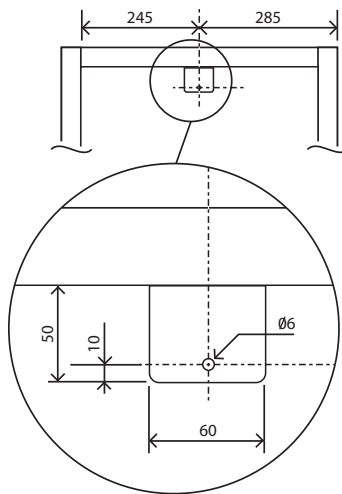
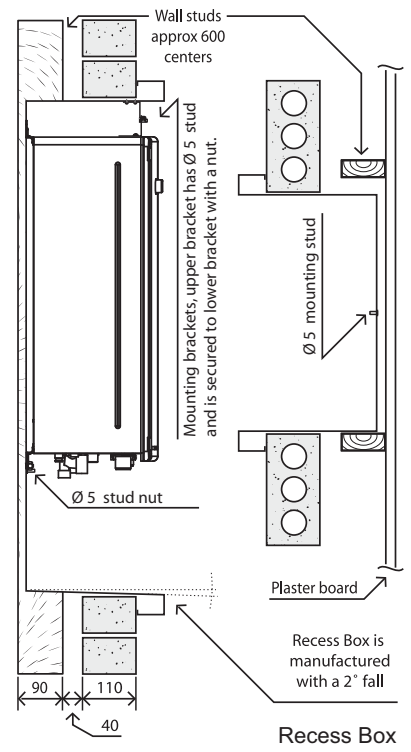
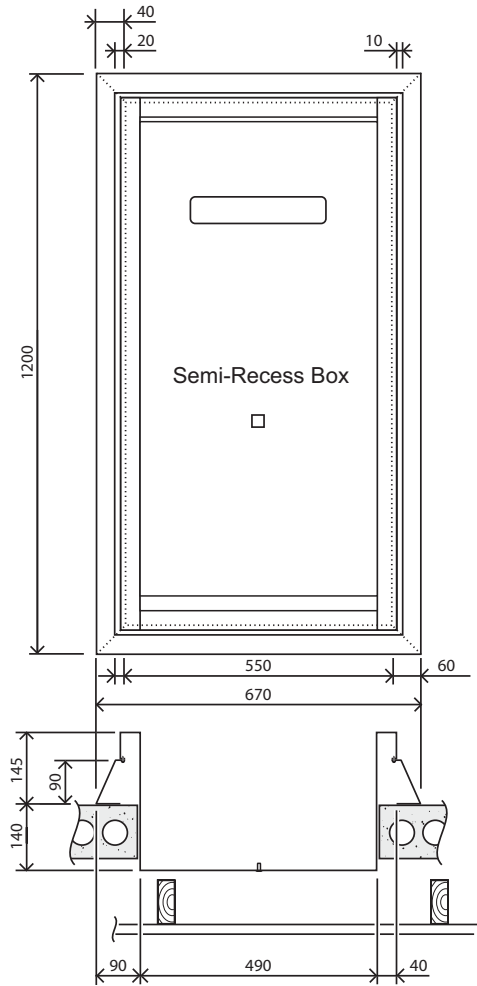
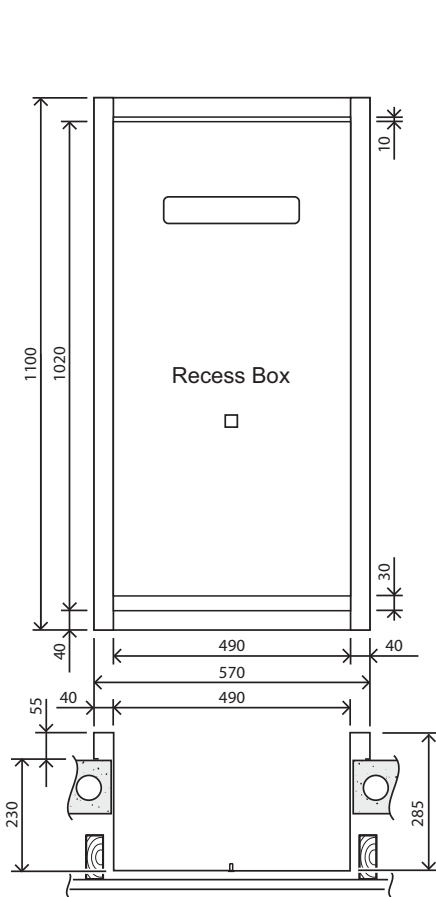

Fig 1.

If you require further information, please call the Rinnai Customer Care Centre **1300 555 545**

DIMENSIONS & INSTALLATION DIAGRAMS



Rinnai Australia Pty. Ltd.
ABN 74 005 138 769

Call our Help Line on: 1300 555 545