

| DRAWING CHANGES | | | | | |
|-----------------|--------|-------------|----|-----|------|
| REV | ECN NO | DESCRIPTION | BY | CKD | DATE |
| | | | | | |

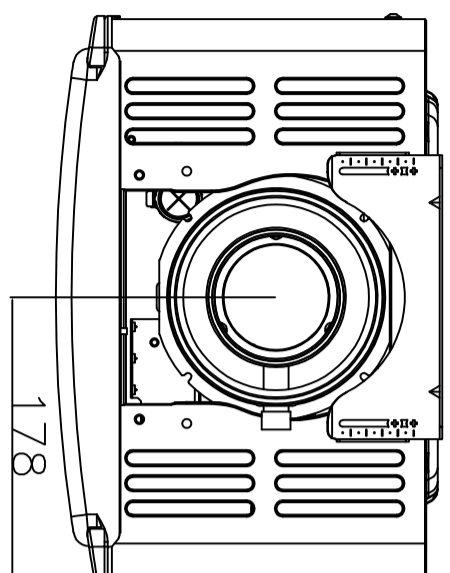

357

178

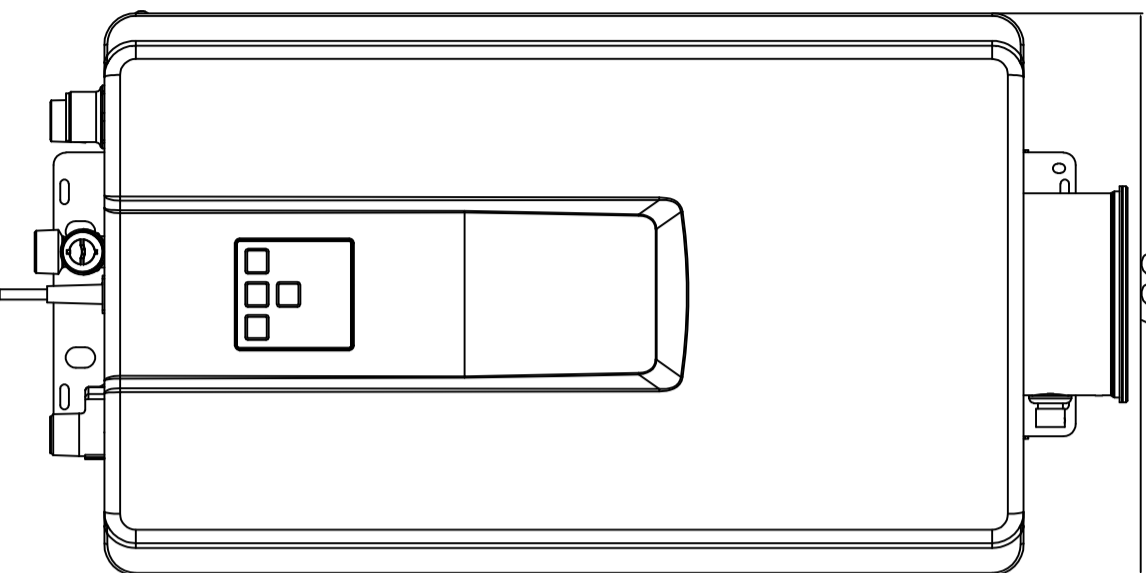

648

105

245

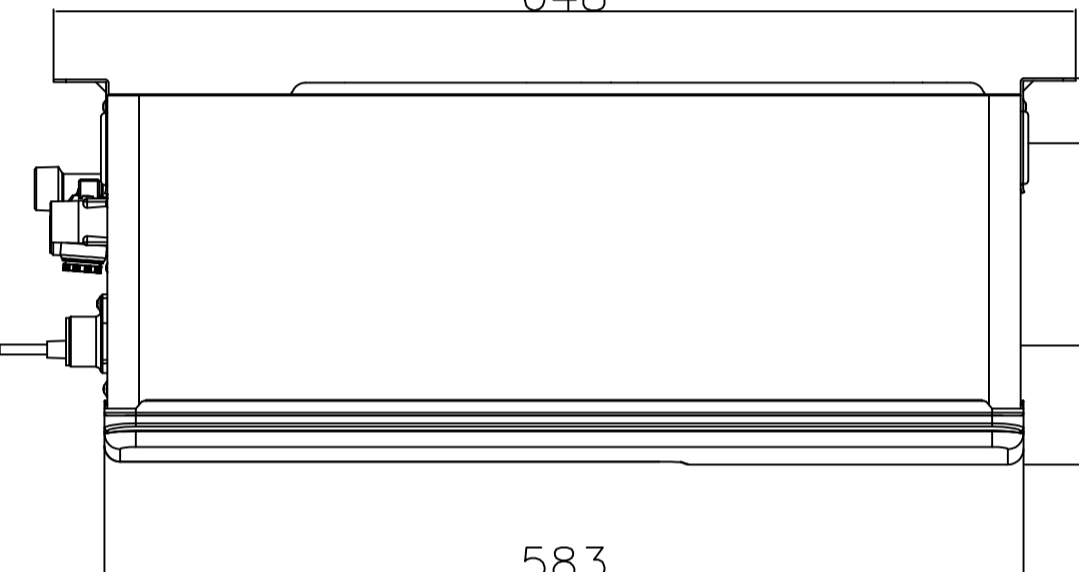

583

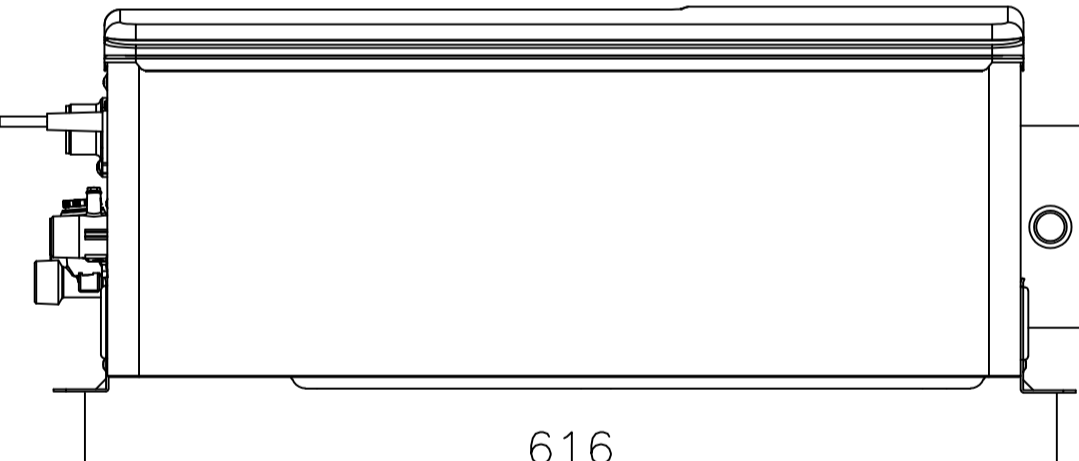

125

616

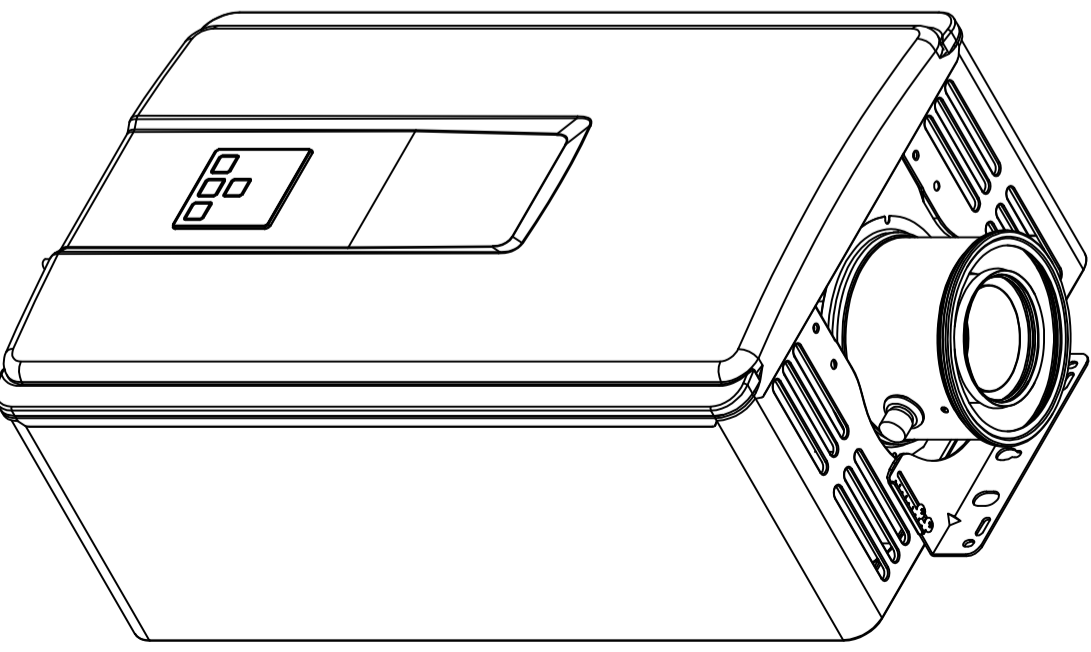

| GENERAL NOTES | |
|-----------------|------------------------|
| GAS CONSUMPTION | 210 MJ/h |
| WEIGHT | 21 kg |
| MIN WATER FLOW | 1.4 L/min |
| OUTPUT CAPACITY | 48 kW |
| POWER SUPPLY | 240V 50Hz |
| GAS CONNECTION | R ₃ *(20mm) |
| COLD CONNECTION | R ₃ *(20mm) |
| HOT CONNECTION | R ₃ *(20mm) |
| SOUND LEVEL | <52 DBA |
| MAX TEMP °C | 85 |

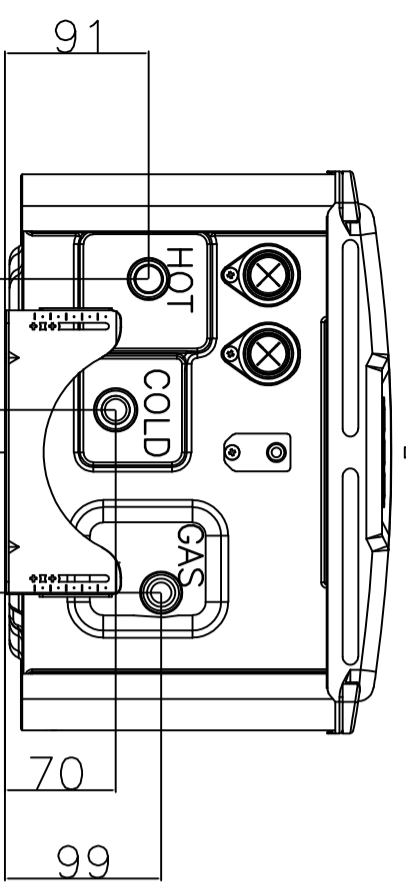

91

HOT

COLD

GAS

27

110

89

70

99

| | | |
|----------------------|----------------------------------------|-------------|
| MATERIAL | TOLERANCE - UNLESS STATED | |
| | 0. ±1.0 | 0.00 ±0.1 |
| | 0.0 ±0.5 | Angular ±1° |
| FINISH: | DIMENSIONS ARE IN MILLIMETERS AS 1:100 | |
| | HARD ANGLE PROJECTION | |
| DO NOT SCALE DRAWING | DATE | 26/08/21 |
| | CHECKED | SVL |
| | APPROVED | |
| | DRAWN | RMP |

Rinnai Australia Pty Ltd

HD28 INTERNAL

SEE NOTES

SK 0258

Revision 1