

| DRAWING CHANGES | | | | BY | CKD | DATE |
|-----------------|---------|-------------|--|----|-----|------|
| REV | ECON NO | DESCRIPTION | | | | |

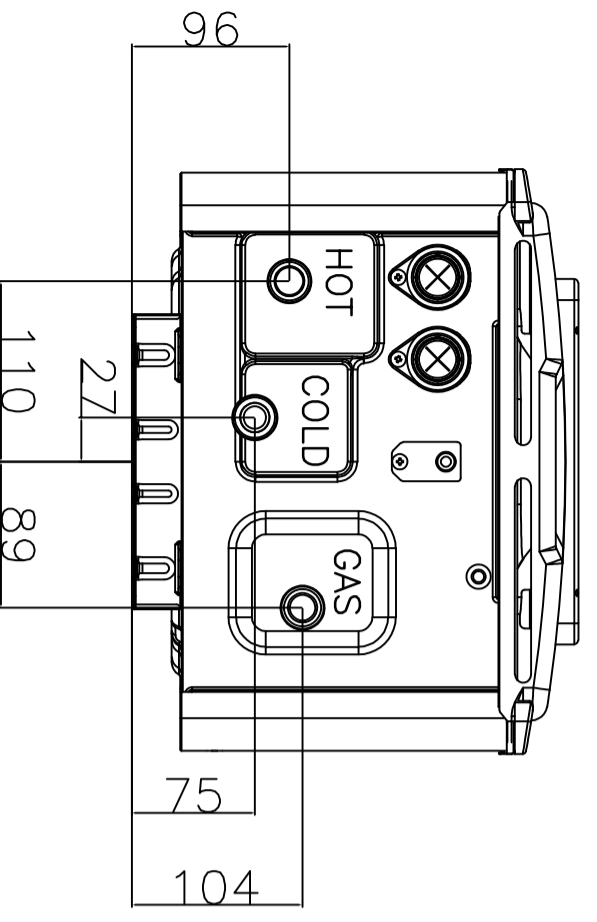
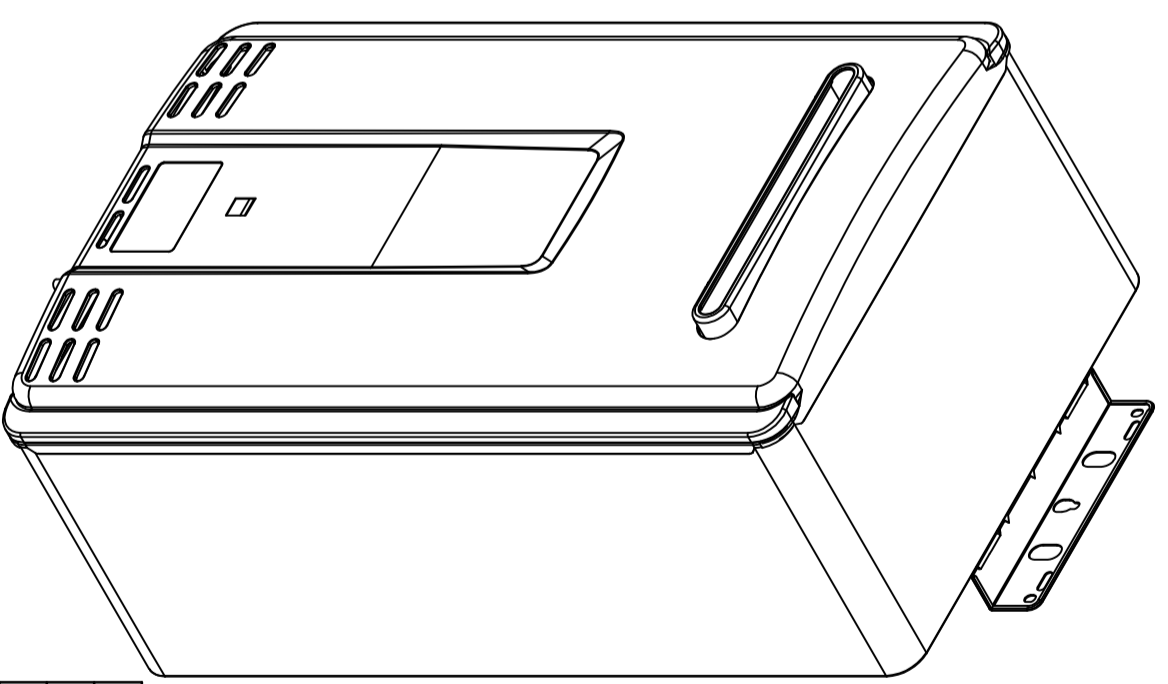
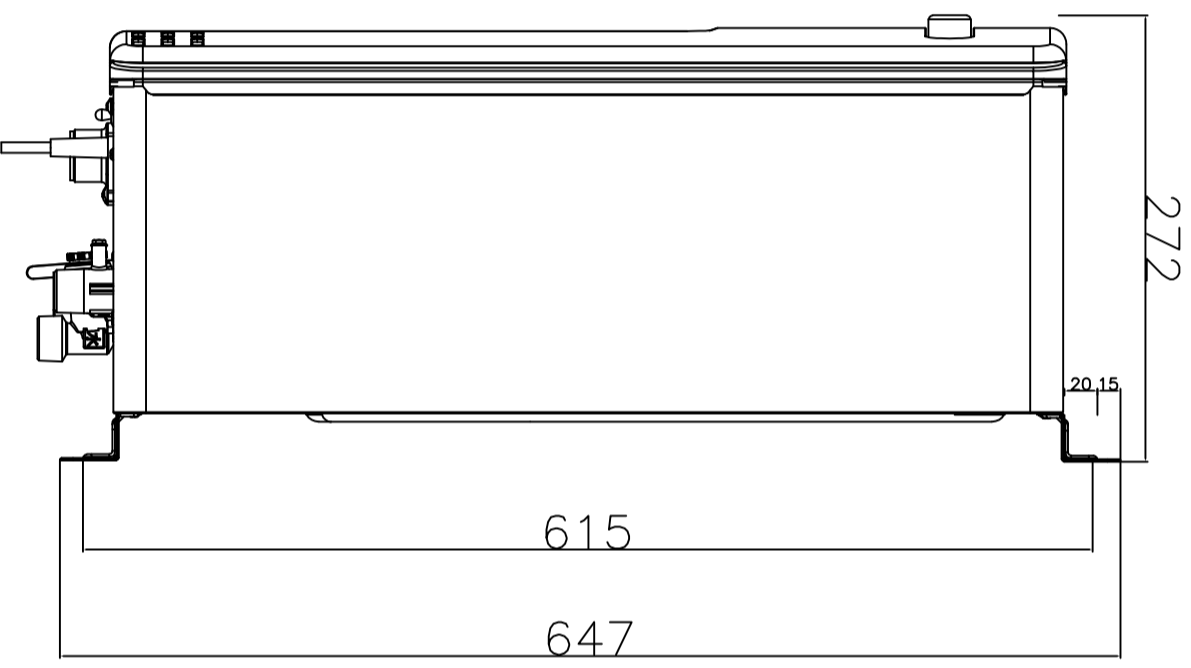
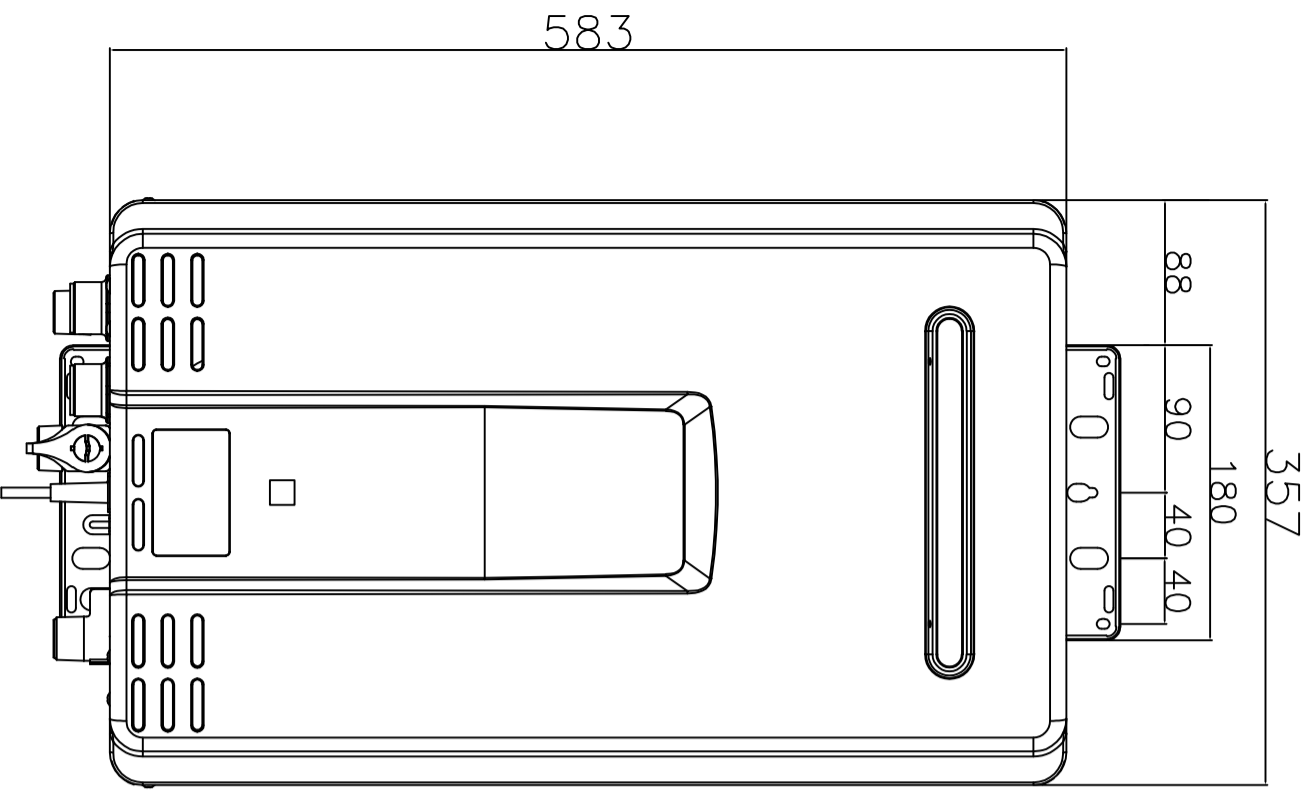

| GENERAL NOTES | |
|-----------------|-------------------------|
| GAS CONSUMPTION | 210 MJ/h |
| WEIGHT | 20 kg |
| MIN WATER FLOW | 1.4 L/min |
| OUTPUT CAPACITY | 48 kW |
| POWER SUPPLY | 240v 50Hz |
| GAS CONNECTION | R ₃ <(20mm)> |
| COLD CONNECTION | R ₃ <(20mm)> |
| HOT CONNECTION | R ₃ <(20mm)> |
| SOUND LEVEL | <52 DBA |
| MAX TEMP °C | 85 |

| | | |
|--|---------------------------|-------------|
| MATERIAL | TOLERANCE - UNLESS STATED | |
| | 0. ±1.0 | 0.00 ±0.1 |
| | 0.0 ±0.5 | Angular ±1° |
| FINISH: | | |
| DIMENSIONS ARE IN MILLIMETERS AS 1:100 | | |
| THIRD ANGLE PROJECTION | | |
| DRAWN | RMP | DATE |
| CHECKED | SVL | 20/08/21 |
| APPROVED | | |
| DO NOT SCALE DRAWING | | |

Rinnai Australia Pty Ltd

Title: **HD28 EXTERNAL**

Weight: **SEE NOTES**

Drawing Number(PART NO): **SK 0257**

Revision: **1**